

ITEM NO.	PART NUMBER	DESCRIPTION	QTY.
1	11506441	TURNTABLE ASSY-90mm-HEAVY DUTY-EXTRA WIDE	1
2	11505671	Jaw, OSC Turntable	1
3	11432675	Pin, Jaw	2
4	11505264	SLIDE ASSY-LOCK	1
5	11505803	PLATE-SLIDE BLOCK TIE	1
6	11453124	WASHER - 14x27x2.8	10
7	11505814	LEVER-TRIGGER	1
8	11505253	Bush, Lock Arm	1
9	11404757	Nut, Lock, M12	7
10	11496849	SETSCREW; HEX HD: M12x30 :CL 8.8	2
11	11481713	WASHER-SPRING 12DIA	2
12	11434281	Lever, Safety	1
13	11435249	Spacer, Safety Lever	1
14	11434303	Handle Assembly, Complete	1
15	11490172	Chain, c/w D-Shackle	1
16	11489941	Elbow, Male, 90deg	6
17	11496926	1/4 x 1/8 connector male	6
18	11496893	SPRING PIN - 5x26	1
19	11505693	PLATE ASSY-WEDGE BLOCK GUIDE	1
20	11432961	Spring, Trigger	1
21	11432972	Spring, Wedge	1
22	11432983	Spring, Safety Lever	1
23	11506991	PIN-PIVOT	2
24	N500031-001	FOOT, SINGLE, OSC, FABRICATED	2
25	11506430	BUSH-FEET	2
26	11505242	Screw, Countersunk - M12 X 55	2
27	11496959	Circlip, External - Ø45	2
28	11496937	2x20 Split Pin	1
29	11496970	1/8 BSP Grease Nipple	10

MODEL No: KS15E902236

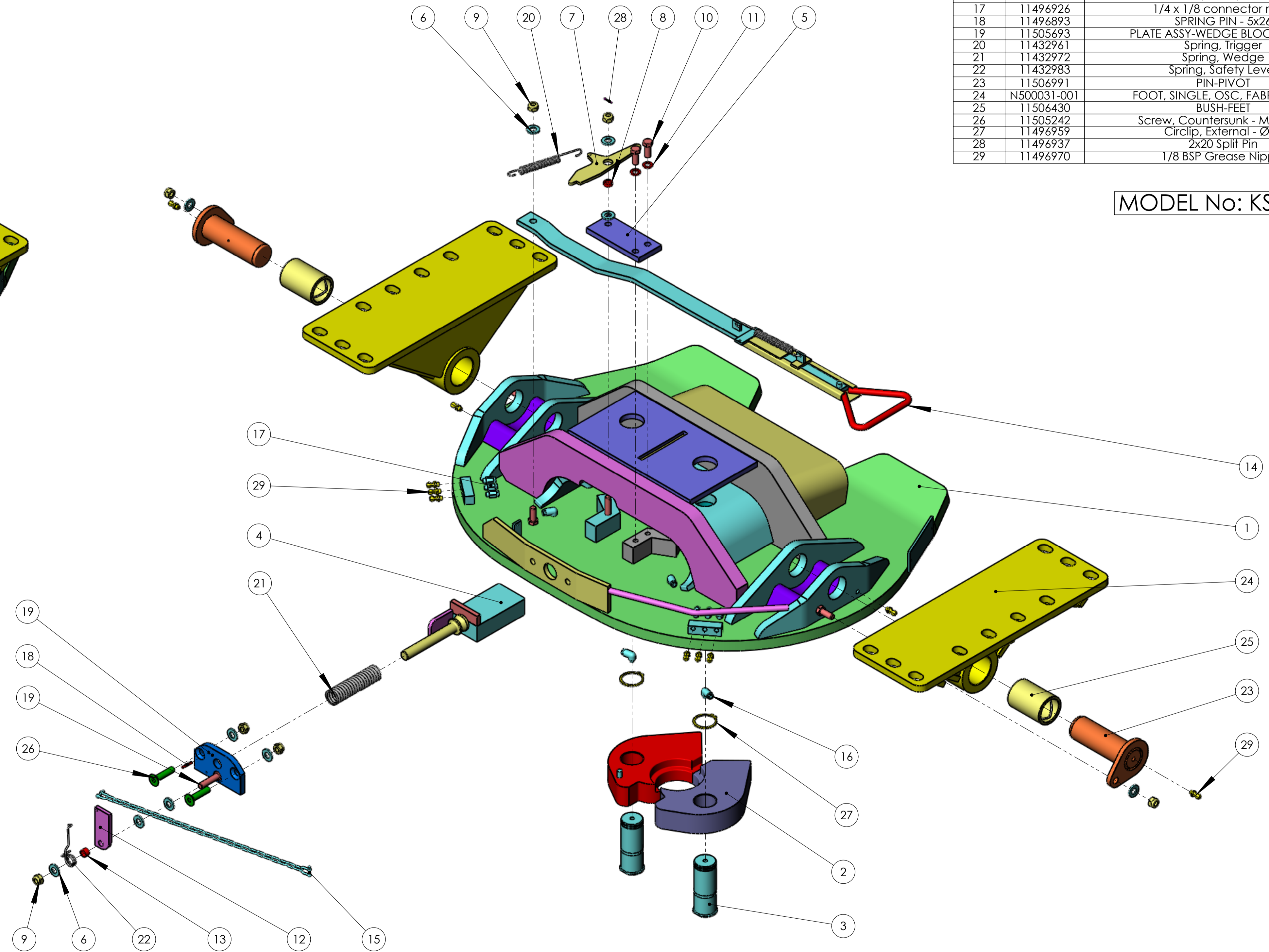

<small>This print remains the property of Fuwa K HITCH Pty Ltd. All information contained therein is confidential. It is loaned, subject to return on demand and on express condition that it is not to be copied or used directly or indirectly for any purpose other than the purpose for which it has been loaned to you.</small>			Fuwa K HITCH Pty Ltd 13-21 Bels Court RD Derrimut VIC 3030 Copyright © 2009	P/N: FKH-001 Evidence is standard unless otherwise stated. P/N: FKH-002 Quality notes	 REMOVE ALL BURRS SHARP EDGES AND PROCESS RESIDUE	MATERIAL: See Components SURFACE FINISH: - WEIGHT: 274kg BOM: - Project No. Revision Level: 03
DRAWN: D.R. CHK'D: Z.L. APP'VD:	NAME: D.R. SIGNATURE: Z.L. DATE: 11-11-2011 DATE: 11-11-2011	Description: Fifth Wheel - Single Oscillating	Part No. 11506397 SCALE: 1:3 SHEET 1 OF 2			

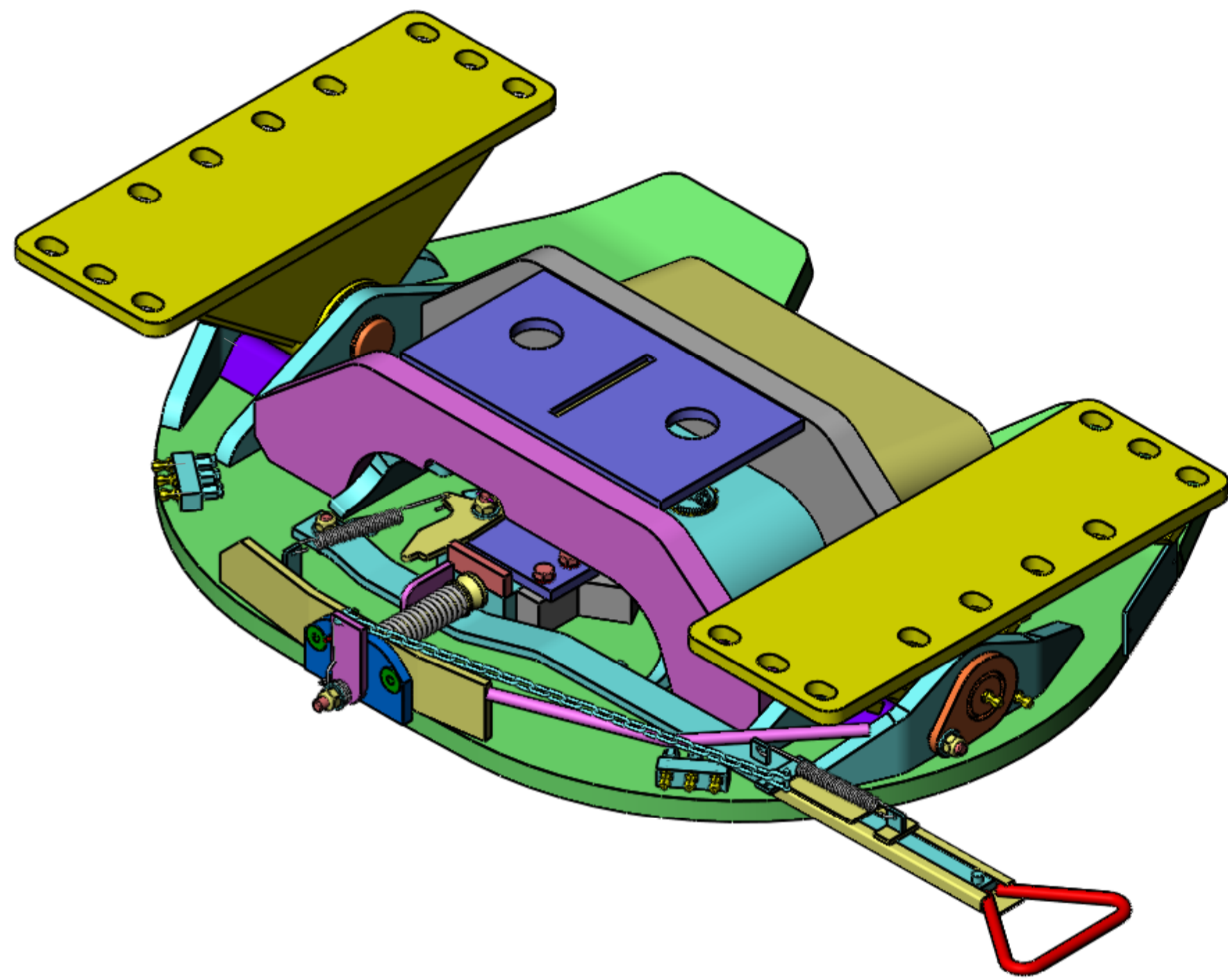
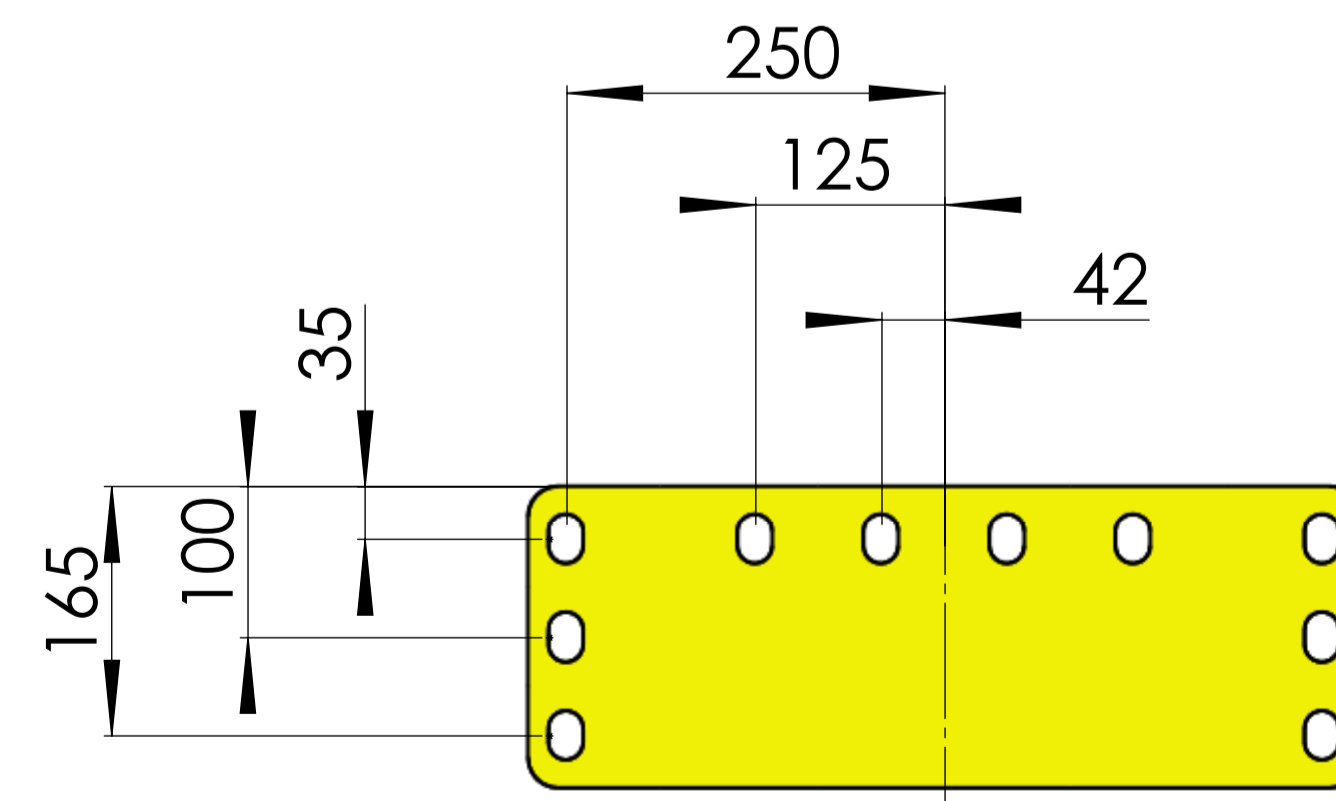
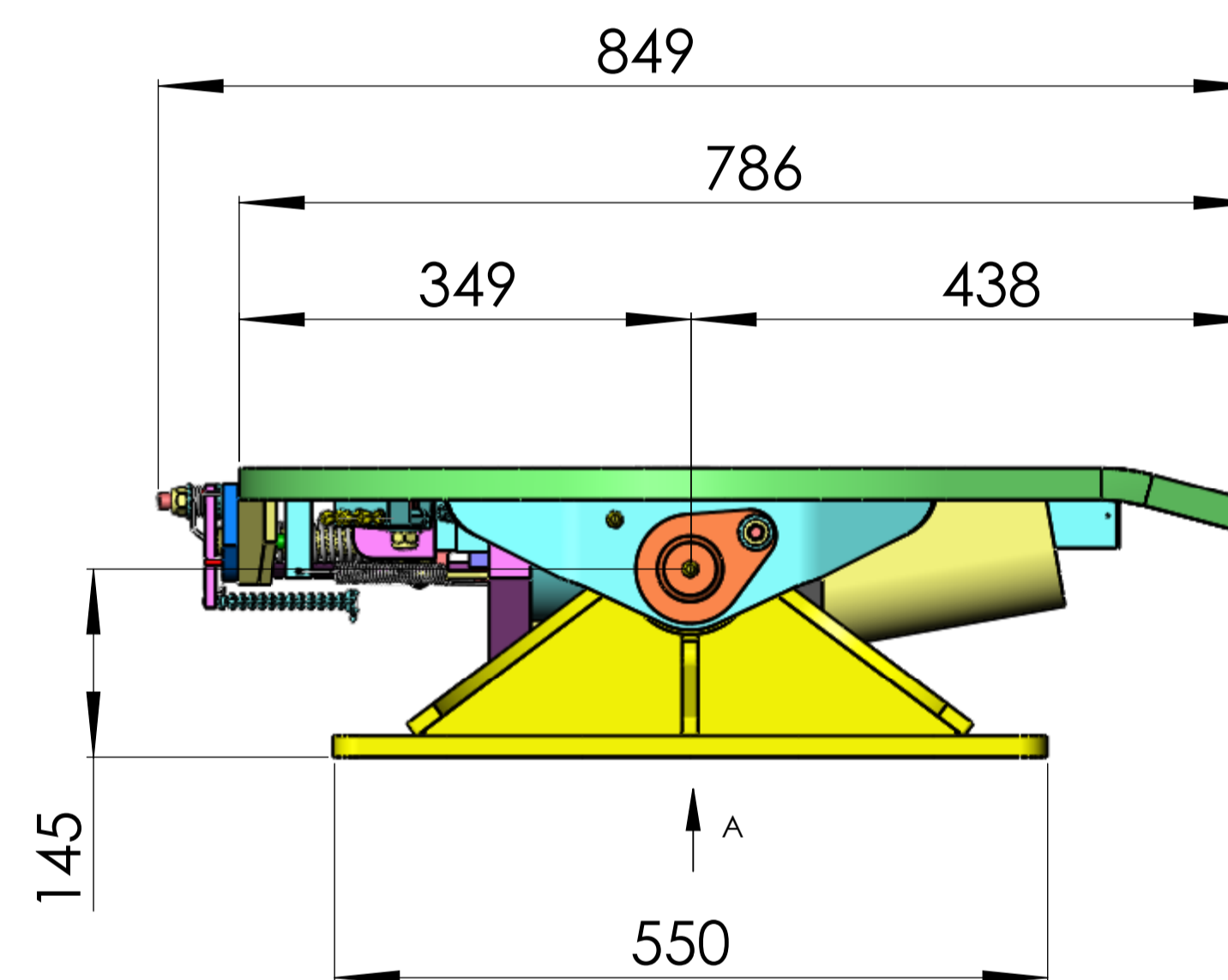
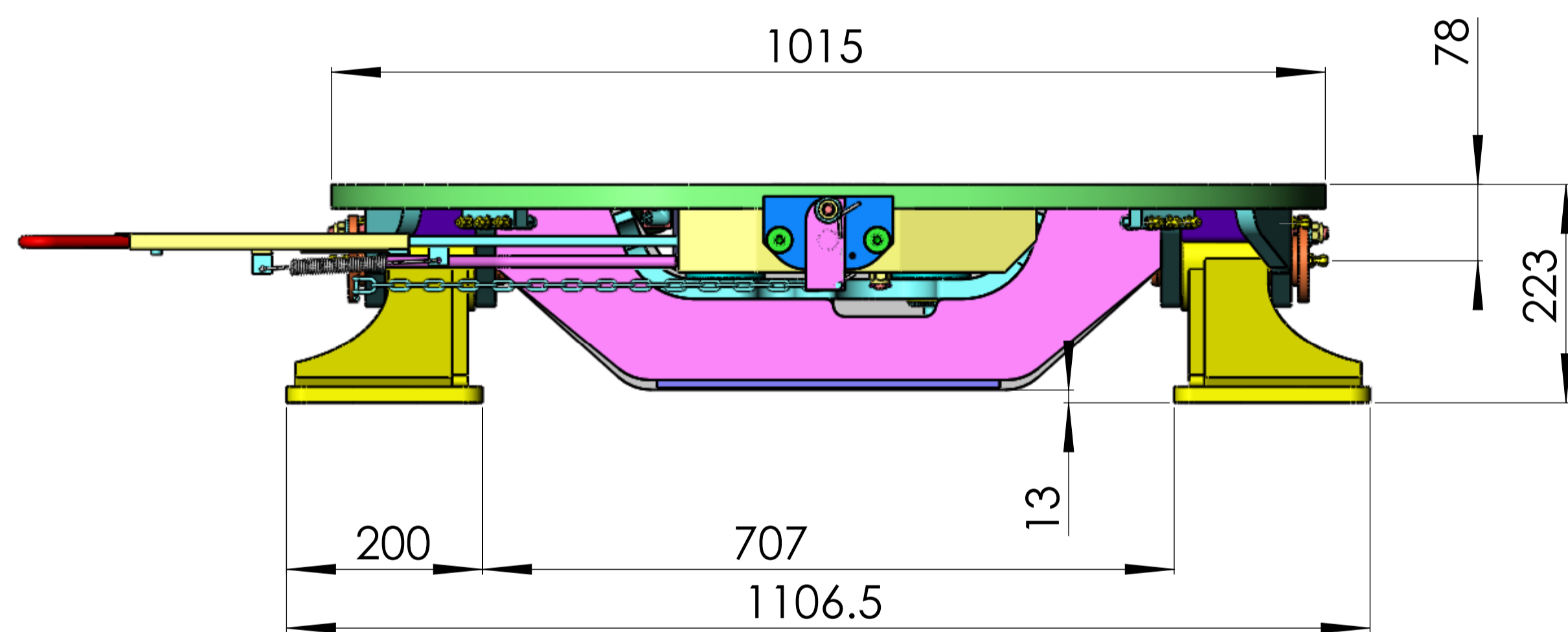
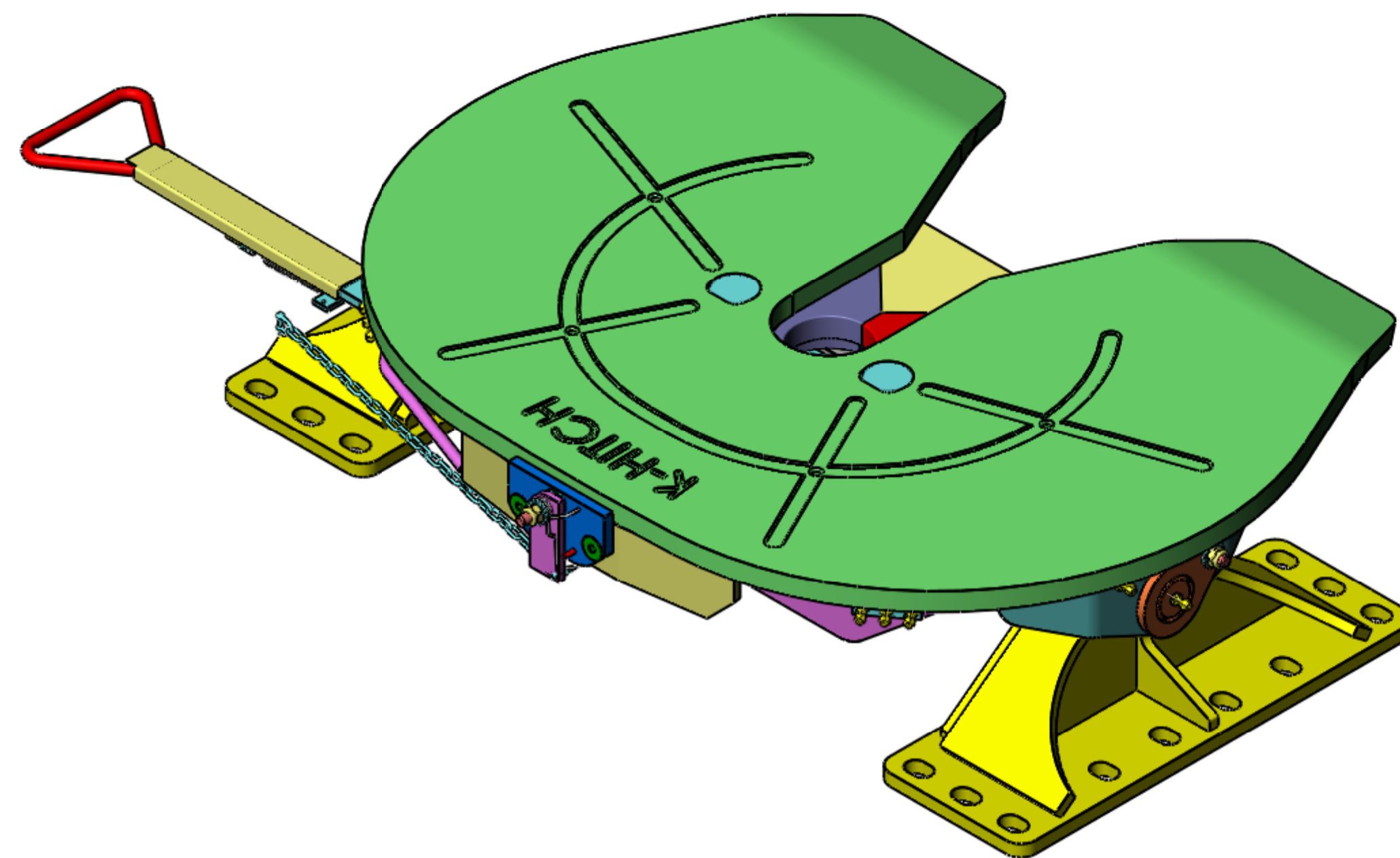
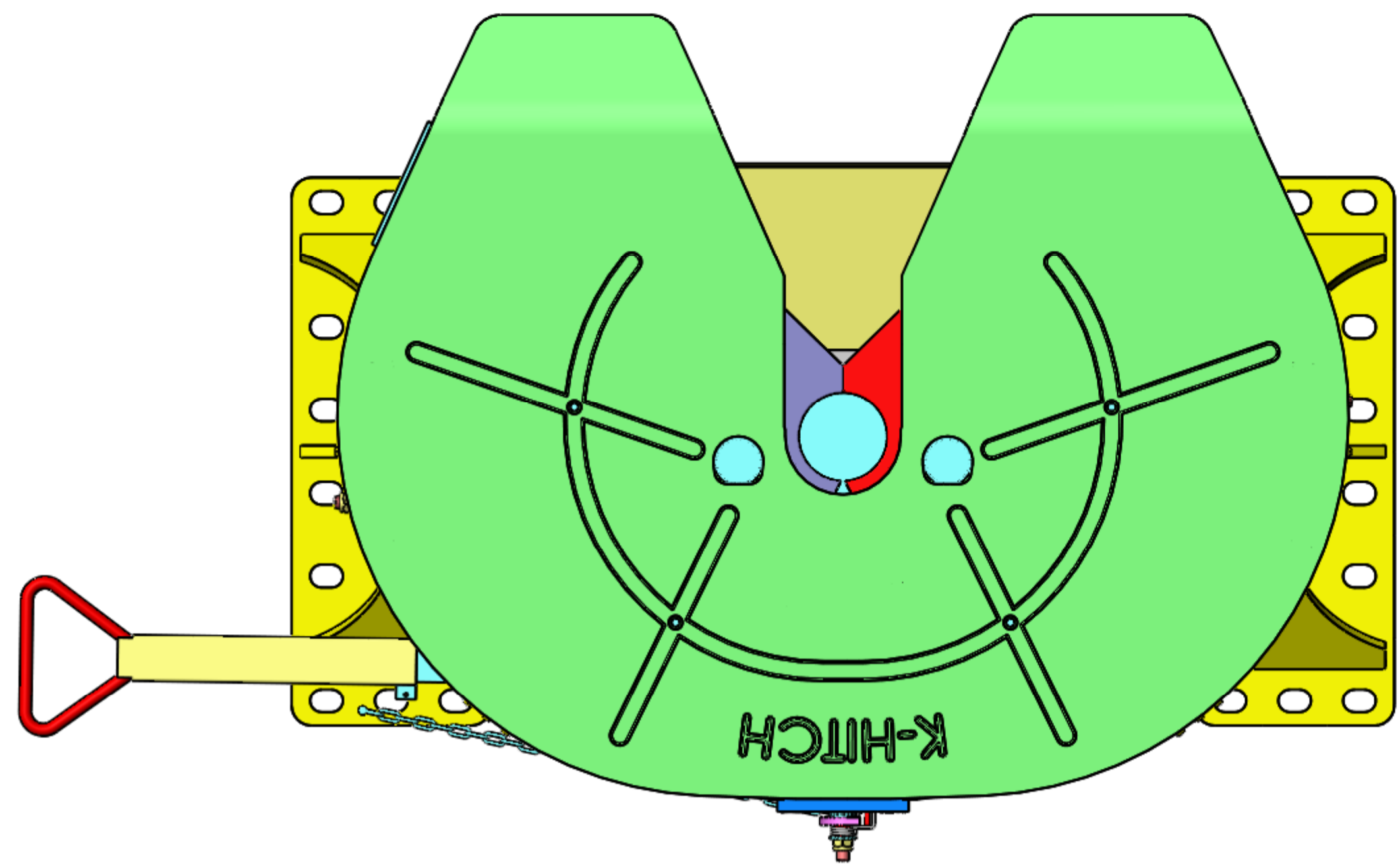

VIEW A

<small>This print remains the property of Fuwa K HITCH Pty Ltd. All information contained therein is confidential. It is loaned, subject to return on demand and on express condition that it is not to be copied or used directly or indirectly for any purpose other than the purpose for which it has been loaned to you.</small>			Fuwa K HITCH Fuwa K HITCH Pty Ltd 13-21 Bels Court RD Derrimut VIC 3030 Copyright © 2009	P/N: FH001 Tolerance is standard unless otherwise stated. P/N: FH002 Quality notes	REMOVE ALL BURRS, SHARP EDGES AND PROCESS RESIDUE	MATERIAL: See Components SURFACE FINISH: - WEIGHT: 274kg BOM: - Project No.: Revision Level: 03
DRAWN: D.R. CHK'D: Z.L. APP'VD:	NAME: D.R. SIGNATURE: Z.L. DATE: 11-11-2011 DATE: 11-11-2011	Description: Fifth Wheel - Single Oscillating	Part No.: 11506397	SCALE: A1 SHEET 2 OF 2		