

HEAVY DUTY SUSPENSION RANGE

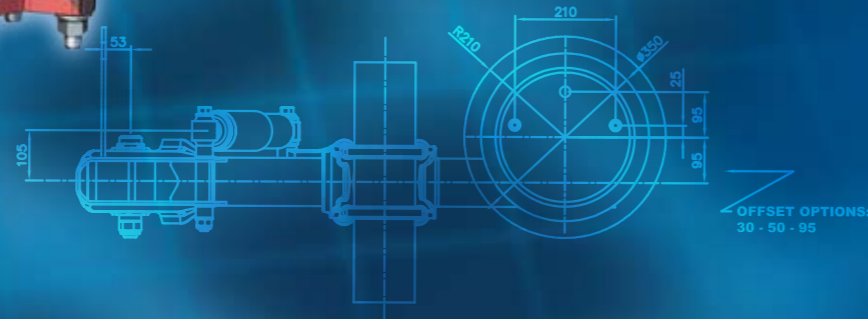

2 YEARS WARRANTY
ON NON WEAR PARTS
AND 2 YEARS
PROVISIONAL ON
WEAR PARTS



FEATURES:

- Maximum Axle Load: 11T.
- Double leaf trailing arm
1st: 100x35mm
2nd: 100x45mm
- Available ride heights:
Underslung systems: 195-350
Overslung systems: 390-570

Weweler.
*Leadership in
suspension technology*

HEAVY DUTY SUSPENSION RANGE has an 11 tonne rating and has been developed to suit most heavy duty of road applications including road train, dolly, livestock, low loaders etc.

SPECIFICATIONS:

| RIDE HEIGHT RANGE | TRAILING ARM | AIR BELOW | OFFSET OPTIONS |
|-------------------|--------------|-------------------|----------------|
| 195-295 mm | BG (530/385) | E1ST2 (ø 350 mm.) | 56 mm |
| 240-290 mm | BG (530/385) | E2ST2 (ø 350 mm.) | 56 mm |
| 240-340 mm | BD (530/325) | E1ST2 (ø 350 mm.) | 30-50-95 mm |
| 275-350 mm | BG (530/325) | E2ST2 (ø 350 mm.) | 30-50-95 mm |
| 240-340 mm | BJ (530/380) | E1ST2 (ø 350 mm.) | 30-50-95 mm |
| 275-350 mm | BJ (530/380) | E2ST2 (ø 350 mm.) | 30-50-95 mm |
| 390-465 mm | GE (530/375) | E1ST2 (ø 350 mm.) | 30-50-95 mm |
| 375-475 mm | GE (530/375) | E2ST2 (ø 350 mm.) | 30-50-95 mm |
| 445-520 mm | GF (530/380) | E1ST2 (ø 350 mm.) | 30-50-95 mm |
| 490-540 mm | GF (530/380) | E2ST2 (ø 350 mm.) | 30-50-95 mm |
| 470-570 mm | BO (530/325) | E1ST2 (ø 350 mm.) | 30-50-95 mm |

WEWELER
IMPROVING TRANSPORTATION

