



FUWA K HITCH (Australia) Pty Ltd

ABN 54 078 731 209

Head Office

Melbourne

13-21 Bliss Court
Derrimut VIC 3030
Tel. 03 9369 0000
Fax. 03 9369 0100

Queensland

41 Moreton
Heathwood Qld 4110
Tel. 07 3372 2223
Fax. 07 3372 1022

Perth

77B Kurnall Road
Welshpool WA 6106
Tel. 08 9350 6470
Fax. 08 9350 6570

SALES SPEC SHEET

AXLE FB24

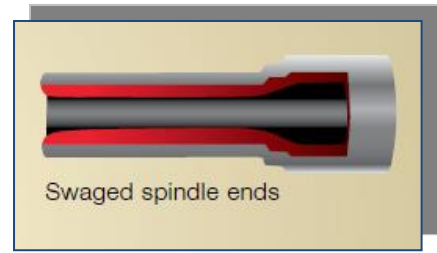

The K Hitch series of **ONE-PIECE FORGED AXLES** are available in a variety of configuration to suit most application.

The following model information is specific to the FB24, but features like induction hardened bearing journals, premium bearings and seals are standard to all FUWA K HITCH axles. The OE quality brake callipers are supplied by WABCO.

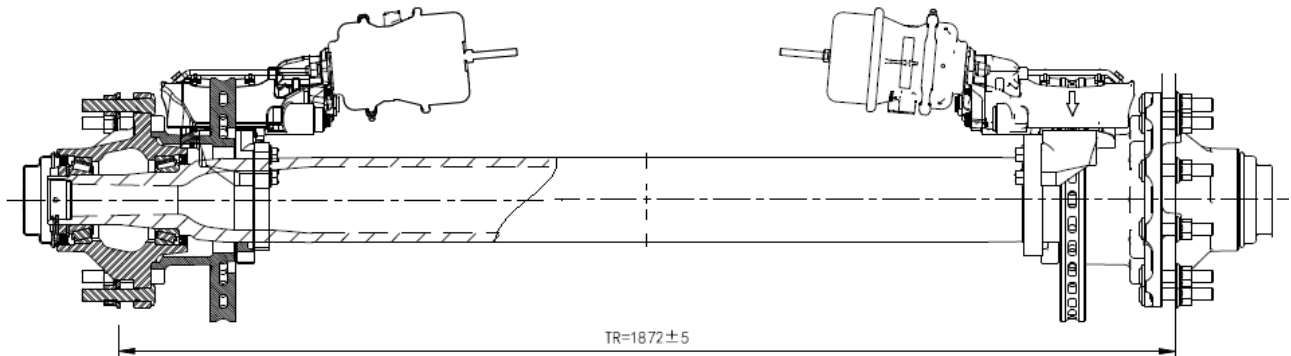

CAPACITY TON	BEARING TYPE	BRAKE TYPE	WHEEL END OPTIONS
17t	TN - HD	WABCO PAN 22 Ø 430mm Rotor	10x335

TRACK	WEIGHT	ABS	AXLE BEAM SIZE	LUBE
1872	390KG*	On Request	□ 150x150 x18	GREASE (OIL ON REQUEST ONLY)

Note*: FB24 DB012



FUWA K HITCH (Australia) Pty Ltd

ABN 54 078 731 209

Head Office

Melbourne

13-21 Bliss Court
Derrimut VIC 3030
Tel. 03 9369 0000
Fax. 03 9369 0100

Queensland

41 Moreton
Heathwood Qld 4110
Tel. 07 3372 2223
Fax. 07 3372 1022

Perth

77B Kurnall Road
Welshpool WA 6106
Tel. 08 9350 6470
Fax. 08 9350 6570

FB 24 SERVICE INFORMATION

BULLETIN NUMBER	TOPIC	DESCRIPTION
KPW-002-0110	Warranty	Limitation of Liabilities
KPW-004-0110		LGL's
KPM-001-0110		Claim Form
KPM-001-0814	Installation	List of all Bulletins which are useful and may need to be referred to when installing a FKH axle. Application specific engineering drawings are available upon request.
KPS-002-0513	Parts	Parts View
KPM-004-0310 PAN22-1-Service Manual	Maintenance	In service maintenance

Bulletins:

All Bulletins are on: www.khitch.com.au

...or call FKH at your nearest location.

