

INSTALLATION, MAINTENANCE & SERVICE BULLETIN

HUB & WHEEL INSTALLATION

1.0 SCOPE

This specification covers the torque requirements for the attachment of all component parts of Spoke Wheels, Rims, Tyres and Hub assemblies.

1.1 Spoke Wheels

CAUTION: Always deflate tyres prior to demounting.

If there is any evidence of damage to the rim or lock ring, or if the lock ring appears to be unseated, the tyre should be **completely deflated** prior to the removal of the tyre and rim assembly from the vehicle. After removal of the tyre and rim assembly, clean and carefully inspect the wheel spokes for damage. Inspect the rim clamps and rim clamp nuts for any sign of cracking or distortion; any damaged parts should be replaced immediately.

DO NOT WELD SPOKE WHEEL.

Welding on any portion of a Spoke Wheel will result in substantial structural damage.

INSTALLATION, MAINTENANCE & SERVICE BULLETIN

1.1.1 Installation Procedure

A typical assembly for a single and dual rim assembly is shown in Figure 1. The correct installation and tightening of the tyre and rim assembly on the spoke wheel is one of the most important operations in wheel maintenance. When tyre/rim/spoke wheel problems occur, incorrect installation and tightening procedures are nearly always found to be the cause of the problems. The following procedures must be carefully followed to ensure safe and dependable service.

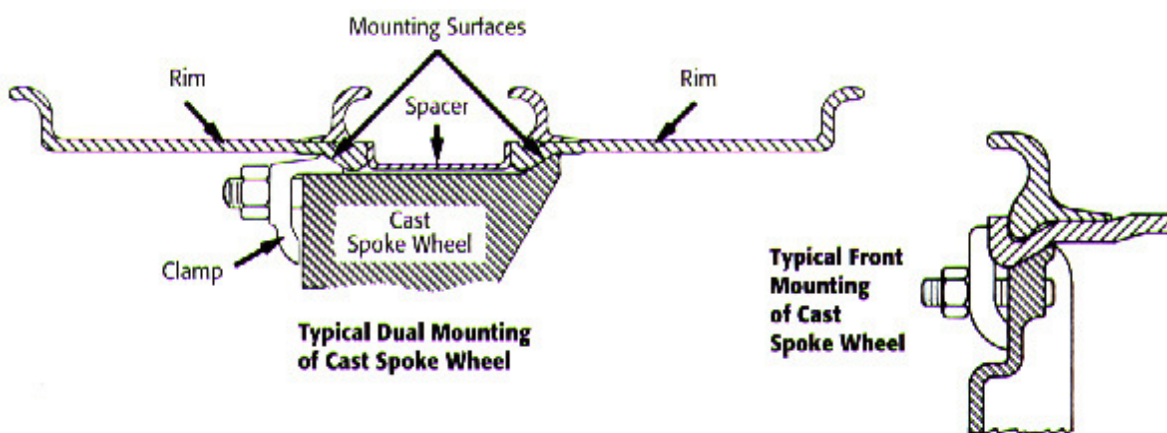

Figure 1 - Spider - single and dual.

1. Clean the spoke wheel and rim mounting surfaces making sure that they are free from damage, paint, dirt or rust. A wire brush should be used.
2. Slide the inside tyre and rim assembly over the cast spoke wheel and push back into position so that the 28 degree mounting surfaces mate. Be sure that the valve stem points out and is centred between two spokes.

1.1.1 Installation Procedure (Cont.)

3. Check the rim spacer for concentricity and assure yourself it has not been distorted or bent. **Never install a bent or distorted rim spacer.** Push the rim spacer over the spoke wheel with a consistent pressure on both sides. Guard against 'cocking' the rim spacer on the spoke wheel. The rim spacer should fit snugly on the spokes and against the inside rim gutter edge.
4. Slide outside tyre and rim assembly over the spoke wheel and push back into position. Be sure the valve stem points in and is centred between the same spoke as the inner valve stem. By placing the valve stems in this manner, both the inner and outer valve stems are accessible for tyre inflation.

INSTALLATION, MAINTENANCE & SERVICE BULLETIN

5. Install all rim clamps and nuts. Run the rim clamp nuts down until the end of the stud is flush with the face of the nut, then revolve the wheel and tyre one half turn to allow the parts to seat naturally.
6. Tighten the rim clamp nuts down until they are snug, using the crisscross method as shown for 3, 5 and 6 spoke wheels. Always rotate the nut to be tightened to the top position as shown (Figure 2) to ensure even application of the clamp forces against the rim for proper alignment.

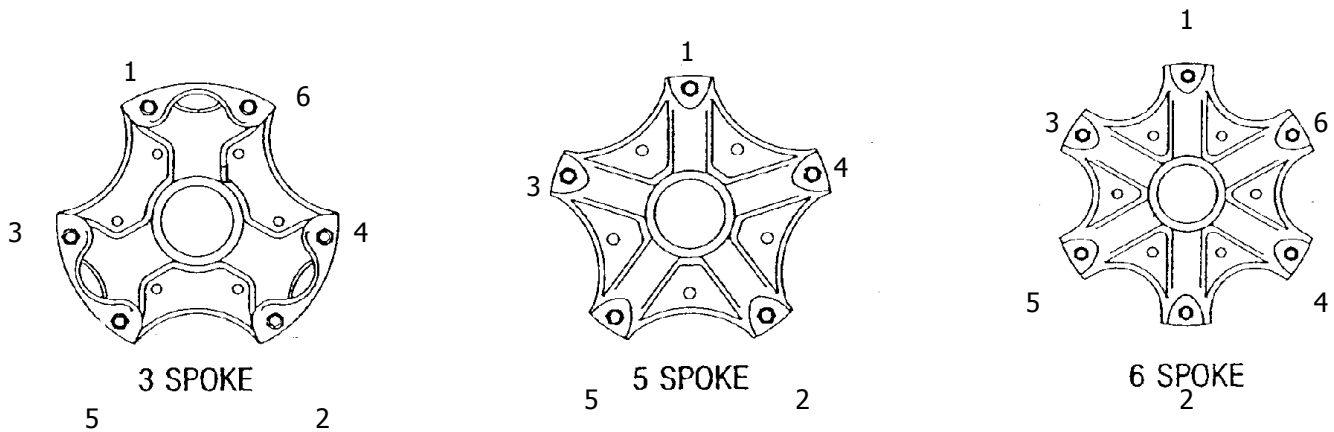

Figure 2 - 3,5,6 spoke tightening sequence

1.1.2 Torque Requirements -

1.1.2.1 Torque requirements on Rim Clamp nuts.

Following the same sequence as used in Step 6, tighten the rim clamp nuts to the recommended torque value shown in Table 1.

Axle Type/loading capacity	Stud side and Threads/inch	Recommended Torque*
Front/<6.3 ton (14,000lb)	3/4" x 10	292 - 332 N.m (215 - 245 lb.ft)
Front/>6.3 ton (14,00lb)	3/4" x 10	325 - 353 N.m (240 - 260 lb.ft)
Rear/All	3/4" x 10	292 - 332 N.m (215 - 245 lb.ft)
Trailer/All	3/4" x 10	292 - 332 N.m (215 - 245 lb.ft)

*Stud threads must be clean and dry.

Table 1 - Torque Specifications

INSTALLATION, MAINTENANCE & SERVICE BULLETIN

1.1.2.2 Torque requirements on Rim Clamp and Inner Drive studs

The torque requirement of the rim clamp studs is **85 N/M plus or minus 5 N/M**, and for the inner drive studs is **100 N/M plus or minus 10 N/M**.

CAUTION:

Insufficient mounting torque can cause rim slippage resulting in broken valve stems, worn parts and damaged tyres/wheels. Excessive mounting torque can cause damage by bending and/or stripping studs collapsing rim spacers or forcing rims into an out-of-round condition.

Double ended socket wrenches are adequate to remove and install the tyre and rim assemblies; alternatively, calibrated torque gun can be used.

Air wrenches are sometimes used to save time and labour. The torque they deliver depends upon the air line pressure from which they operate. Periodic checks using a manual torque wrench should be made, to ensure the accuracy of these air wrenches. An air wrench calibrated to exert 678 N.M (500 lb.ft) will bend the studs and distort the rim spacers during initial installation.

1.1.2.3 Torque Requirements on Drum bolts.

The torque requirement of the drum bolts and nuts is 380 N.M - 425 N.M. Tighten the lock nuts to required torque either using a torque gun or torque wrench.

The tightening sequence for the drum bolts and nuts is illustrated in Figure 3.

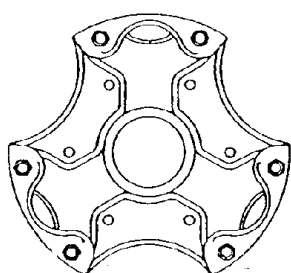

3 SPOKE

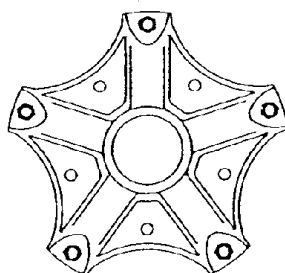

5 SPOKE

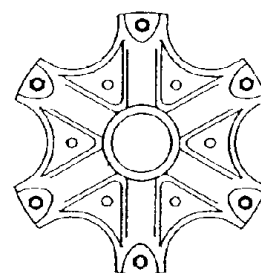

6 SPOKE

Figure 3 - Tightening sequence for Drum Bolts and Nuts.

INSTALLATION, MAINTENANCE & SERVICE BULLETIN

1.1.3 Rim Clamps –

Caution:

DO NOT OVER TORQUE THE RIM CLAMP IN AN ATTEMPT TO MAKE CLAMP CONTACT THE WHEEL. Rim clamps do not have to heel. Over torque can deform the rim spacer band and damage the back flange.

Attempting to make a clamp heel can severely damage the clamp and the rim stud. Two types of rim clamps are available - one is cast, the other forged. Although these two types of clamps do not appear the same, they are used for the same purpose.

Rim clamps may be furnished in either of two configurations, a heel type or heel-less. Both are shown in Figure 4. Cast rim clamps are available in either heel or heel-less configurations.

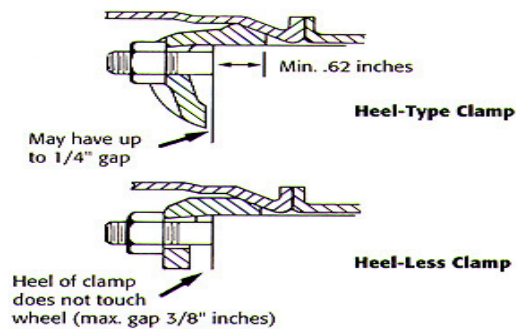

Figure 4 - Heel and Heel-less type Rim clamps.

When installing an assembly using Heel-type Clamps, a gap may be present between the clamp and the surface of the spoke (see Figure 4 - Heel-type Clamp). This condition is permissible but not required. If the gap between the clamp and the surface of the spoke exceeds 1/4" or bottoms out before reaching 80% of the recommended torque, check to ensure that the proper clamps and spacer band are being used.

1.1.3.2 Heel-less Clamps.

Heel-less Clamps are designed **NOT** to heel against the wheel to be properly installed. When properly installed, there will be a gap at the bottom of the clamp. The gap should not exceed 3/8" (see Figure 4 - Heel-less Clamp). If it does, the clamp should be removed and checked to make sure that the proper rim clamp and spacer band are being used. Also check to make sure that the wheel is properly installed.



INSTALLATION, MAINTENANCE & SERVICE BULLETIN

1.1.4 Alignment -

Once the rims and tyres have been installed, you must check the assembly for proper alignment. Alignment of cast spoke wheels can be done easily by placing a block of wood on the ground next to the tyre and revolving the tyre and rim assembly. Note any variations in the space between the block of wood and the tyre. If the variation exceeds 1.60mm (1/16") for the front tyres or 3.30mm (1/8") for the rear dual tyres, the rim is not mounted properly on the spoke wheel.

With a nominal stack up of the spoke wheel, rim clamp, rim and rim spacer, the dimensions can result in a clamp-to-spider (spoke) gap of 6.11mm (0.28"). A maximum allowable gap of 9.65mm (0.38") between the clamp and wheel is possible and is not detrimental to satisfactory operation. More importantly, the length of the clamp bearing surface extending on to the spoke at the minor spoke OD should be 15.74mm (0.62") for both heel and heel-less clamp configurations.

1.1.4.1 Correcting Rim and Tyre alignment

Misalignment can be corrected by loosening the nuts on the side where the variation is greatest, and tightening the nuts on the opposite side. When the tyre and rim runs true, tighten all nuts but do not exceed the recommended torque specifications.

1.1.5 Checking Rim Clamp nut torque

After the vehicle has run a short distance, 80 to 160 km (50 to 100 miles), the assembly will 'seat' and the torque will usually drop and will have to be adjusted. Therefore, it is very important to check the rim clamp nuts for proper torque using the crisscross method. A second tightening will ensure a good, tight, well aligned wheel assembly.

It is very important at this time that the Rim Clamp nuts again be brought up to the recommended torque. The wheel and rim assemblies should then remain tight, barring stud/nut/clamp breakage or wheel damage. During the normal operation of the vehicle all the rim clamp nuts *MUST* be checked once a week for proper torque.

1.2 Wheel Hubs -

DO NOT WELD WHEEL HUBS.

Welding on any portion of a Wheel Hub will result in substantial structural damage.

INSTALLATION, MAINTENANCE & SERVICE BULLETIN

1.2.1 Installation Procedure of Wheel Hubs

A typical assembly for a single and dual wheel assembly is shown in Figure 5. The correct installation and tightening of the wheel assembly on the spoke wheel is one of the most important operations in wheel maintenance. Careless mounting is the major cause of hub and wheel problems. Attention to the proper installation of the hub and wheel assemblies will help to avoid unnecessary service problems and downtime while assuring you of maximum service life and safe operation. The following procedures must be carefully followed to ensure safe and dependable service.

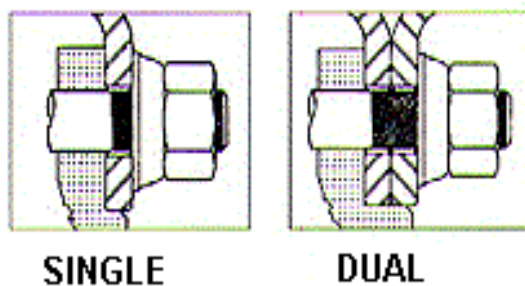

Figure 5 - Single and Dual Wheel assembly.

1. All parts to be used in the installation must be cleaned and dried before beginning the assembly of the hub.
2. If the hub is using grease lubricated wheel bearings, fill the hub with grease to the inside diameter of the outer bearing cup. Also pack grease between the bearing rollers, cones and cage. Use an approved, heavy-duty multi-purpose lithium base (grade 2) grease or synthetic grease. If the hub is using oil lubricated wheel bearings, step 2 is irrelevant, proceed to Step 3.
3. Place the inner bearing in the hub, and install the seal, following the installation procedure provided by the bearing manufacturer.
4. Install the hub by sliding it over the spindle, being careful to not damage the oil seal. Position the outer bearing over the spindle and insert it into position.
5. Install the spindle nuts following specific torque procedures available from the individual axle, bearing, and seal manufacturer. The approved industry standard requires a minimum of 0.001" to maximum of 0.005" end play for adequate seal and bearing performance. End play should be checked after adjustment, using a dial indicator on every wheel-end.

INSTALLATION, MAINTENANCE & SERVICE BULLETIN

NOTE: *Never use an impact wrench to adjust wheel bearings.*

6. When installing non-drive or oil lubricated wheel bearings, fill the hub to the oil level line on the hub cap. Allow time for the lubricant to pass through the outer bearing before re-checking to verify the final oil level. Check the hub cap vent hole to make certain the vent hole is clean.
7. With drive hubs, check the oil level in the drive housing and add oil as required by the manufacturer's specifications.

When installing drive hubs, position a new gasket over the drive studs and install the axle through the hub. Use drive cones as recommended by the axle manufacturer. Torque the nuts to the manufacturer's specifications using a sequence similar to that shown on Figure 6.

If wheel hubs are equipped with oil fill/drain plugs, add a pint of oil to each wheel-end.

If hubs do not have oil/fill drain plugs, each side of the drive axle must be raised a minimum of 203mm (8") to move the lubricant into the opposite wheel-end. After you complete this procedure, re-check the oil level and top off if required.

8. For applications using an outboard mounted brake drum, the drum should now be installed onto the hub pilot positioning it over the mounting studs. Check the drum carefully to make sure it is installing properly and seated correctly before continuing with the wheel-end assembly.

1.2.2 Wheel-end component installation procedures

1. Before you begin the installation, check each part for damage making sure that all studs, nuts, hub and wheel mounting surfaces are clean and free from grease and excess paint. Use a wire brush to clean dirt, rust, burrs, or paint off the mounting surfaces. Replace any damaged or defective parts before beginning the installation. No lubricant is to be used on seating surfaces of the wheels, however, antisieze may be applied to hub pilot pads to prevent corrosion.

Remove all Stud Transport Spacers:

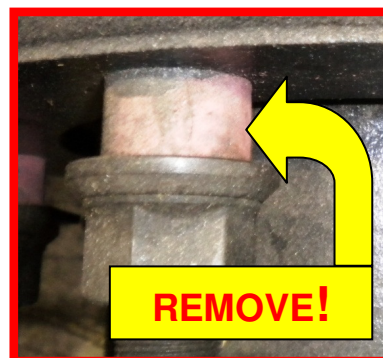

NOTE: *FKH axles, all nuts have right-handed threads.*

INSTALLATION, MAINTENANCE & SERVICE BULLETIN

2. Before mounting wheels, be sure the drum is properly positioned on the raised stop of the pilot pad. Then, mount the single or inner dual wheel over the stud, being careful to not damage any of the threads on the studs.

BEWARE: Only use Hub Piloted Wheels!
 Hub Piloted Wheels do **not** have chamfered stud holes!
 Stud Piloted Wheels are dimensionally different!

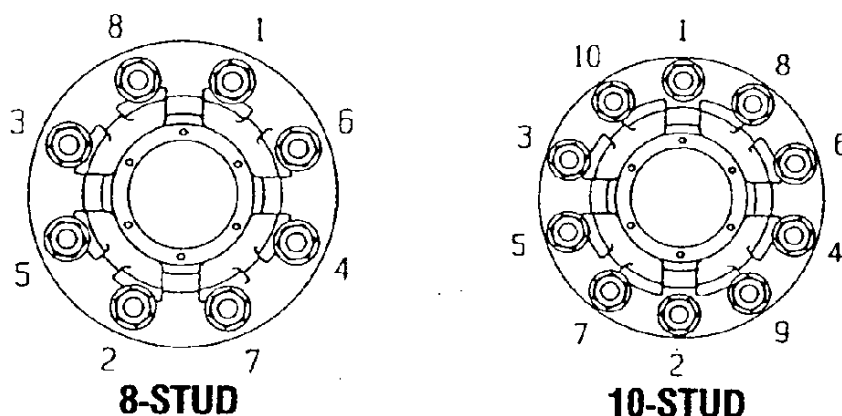

Figure 6 - Proper tightening and torque sequence.

3. Screw in the nuts alternately in the sequence shown in Figure 6. **DO NOT** tighten them fully at this time. Stud and cap nut threads should be clean and dry; no oil should be used beyond the first three threads.
4. It is extremely important that the condition of each nut be checked before installation. Cap nut should not exhibit signs of scarring, cracking or galling. Any nut showing signs of damage should be discarded and replaced with a new nut.

It is also important that you have the correct fasteners. It is extremely important that various nuts are **NOT** interchanged or intermixed.

Nuts used in a hub piloted system **CANNOT** be used in a stud piloted system.

Once the nuts are in place, each nut should be checked for uniform seating.

5. Tighten and torque the nuts fully, using the same alternating sequence as shown in Figure 6. Tighten them only to the recommended torque level as shown in the chart in Table 2. Use a torque wrench to verify the proper torque, especially if an air wrench or bar wrench has been used to tighten the nuts.

INSTALLATION, MAINTENANCE & SERVICE BULLETIN

Mounting Type	Nut Thread/Thread Level	Ft./Lb. (oiled)*
Steel or alloy rims, hub piloted with flange nut..	11/16" - 16	300 - 400
	M20 x 1.5	280 - 330
	M22 x 1.5	450 - 500
	M24 x 1.5	550 - 590

*Apply two drops of motor oil to the point between the nut and the flange and two drops of motor oil to the last two or three threads at the end of each stud.

Mounting Type	Nut Thread/Thread Level	Ft./Lb. (dry)
Stud piloted double cap nut standard type - 7/8" radius	3/4" - 16	450 - 500
	1-1/8" - 16	450 - 500
Stud piloted, double cap nut heavy-duty type - 1-3/16" radius	15/16" - 12	750 - 900
	1-1/8" - 16	750 - 900
	1-5/16" - 12	750 - 900

NOTE: Never lubricate wheel nut, ball seats or mounting faces. If lubrication is desired, it must be used sparingly only on the threads of the studs and/or nuts.

Table 2 - Wheel Hub mounting torque.

NOTE:

If using specialty fasteners, consult the manufacturer for recommended torque levels.

Tightening wheel nuts to their specified torque is extremely important. 'Under' tightening will result in loose wheels which can damage the wheel, studs and hub and can result in wheel loss. 'Over' tightening can damage the studs, nuts and wheels, resulting in loose wheels as well.

Regardless of the torque method used, all torque wrenches, air wrenches or other tools used should be calibrated periodically to ensure that the proper torque.

Bulletin No: KPM-003-0310 Rev 1

For Product Support call: 03 9369 000 / 07 3272 8322 / 08 9353 3655

www.khitch.com.au

INSTALLATION, MAINTENANCE & SERVICE BULLETIN

1.2.3 Check the hubs on new equipment

When taking delivery of new equipment which uses wheel hubs, there are three steps that need to be taken to ensure the equipment is suited to your application and that it will perform safely during normal operation.

1.2.3.1 Verify Hub Load Rating

It is important to verify the hub load rating on new equipment to make sure that it will satisfy the actual load capacity requirements. Some operators install greater capacity tyres to increase the payload. This does not increase the load rating of the hubs. Operating your equipment under extreme conditions or with loads greater than the rated capacity of the hubs may cause damage to the hub and affect vehicle performance.

1.2.3.2 Check the Mounting Nut torque

After the new truck, tractor or trailer has travelled the first 80-160km (50 to 100 miles), the hub/wheel assembly will 'seat', causing the mounting nuts to lose some of their initial torque. In order to assure proper and safe operation, the following procedure **MUST** be followed:-

If two piece flange nuts are used, re-torque to the proper values.

If cap nuts are used, proceed using the following three step procedure -

- . Loosen the outer cap nuts
- . Tighten the inner cap nuts to the proper torque as shown in the torque chart
- . Retighten the outer cap nuts to the proper torque as shown in the torque chart

If this procedure is followed as recommended, the cap nuts should not lose torque during normal operation. It is still necessary for the cap nut torque to be checked regularly as part of a complete preventative maintenance programme.

1.2.3.3 Establish a good Preventative Maintenance Programme

Establishing a good preventative maintenance programme will ensure your equipment performs efficiently and safely. Familiarize your operators and service personnel with the guidelines and procedures recommended in this manual as part of that regular maintenance programme.

INSTALLATION, MAINTENANCE & SERVICE BULLETIN

WARNING:

INSUFFICIENT MOUNTING TORQUE CAN CAUSE WHEEL SHIMMY, RESULTING IN DAMAGE TO PARTS AND EXTREME TYRE TREAD WEAR. EXCESSIVE MOUNTING TORQUE CAN CAUSE STUDS TO BREAK AND HUBS TO CRACK IN THE STUD HOLE AREAS.

SOME HUB PILOTED AND STUD PILOTED WHEELS MAY HAVE THE SAME BOLT CIRCLE PATTERN AND MAY BE MISTAKENLY INTERCHANGED. *CARE MUST BE TAKEN NEVER TO MIX OR INTERCHANGE PARTS BETWEEN HUB PILOTED AND STUD PILOTED WHEEL SYSTEMS.* EACH MOUNTED SYSTEM REQUIRES SPECIFIC COMPONENTS TO ALLOW FOR THE PROPER MATING OF ALL COMPONENTS. IT IS IMPORTANT THAT THE PROPER COMPONENTS ARE USED WITH EACH TYPE OF MOUNTING, AND THAT THE WHEELS ARE FITTED TO THE PROPER HUBS.

IF HUB PILOTED WHEEL COMPONENTS (HUBS, DRUMS, WHEELS, FASTENERS) ARE MIXED WITH STUD PILOTED WHEEL COMPONENTS, LOSS OF TORQUE, BROKEN DRUMS, STUDS, CRACKED WHEELS AND POSSIBLE WHEEL LOSS CAN OCCUR SINCE THESE PARTS ARE NOT DESIGNED TO WORK TOGETHER.