

INSTALLATION, MAINTENANCE & SERVICE BULLETIN

LANDING LEGS



FW37 Series**



KH22 Series



KH25 Series

FYI: For the **eLeg** information go to bulletin KPM-001-0714

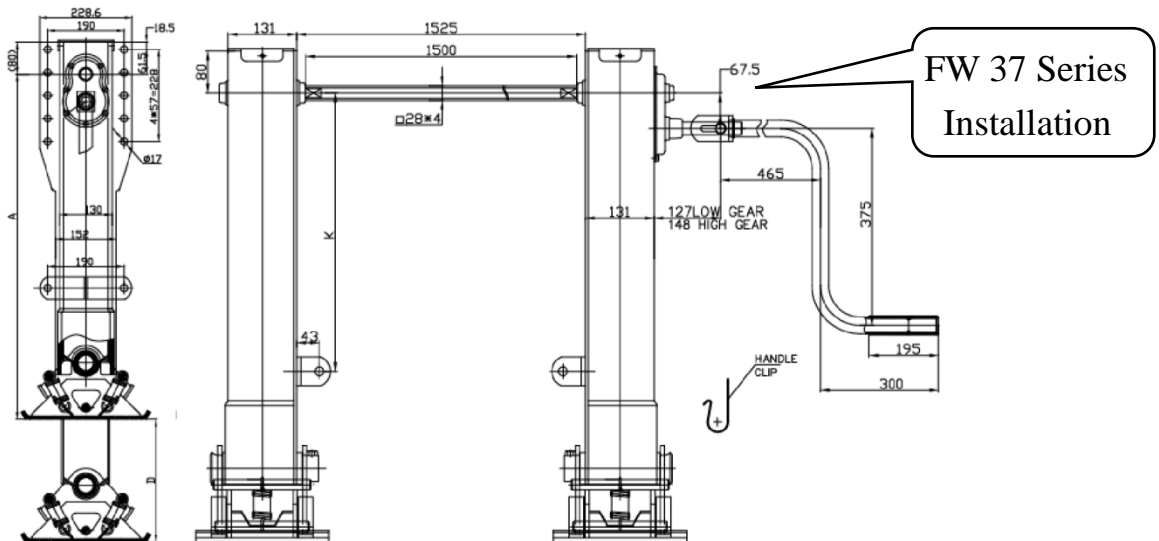

**** Note:** The FH37 model is not available in Europe and the US.

INSTALLATION, MAINTENANCE & SERVICE BULLETIN

Installation

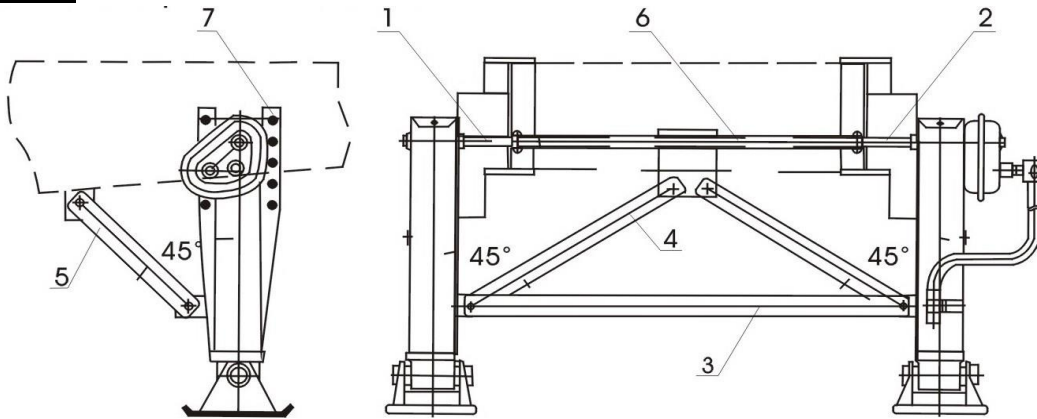
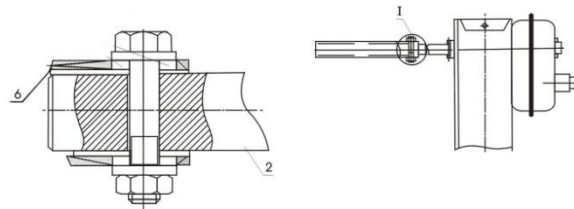

Fig B

1. Before the installation, check that the selected FKH Landing Leg meets the requirements of the application. Check that the correct foot is installed for the application.
2. Both geared and slave leg must be level and square to each other on the chassis.
3. In the final installed position, trailer at working level, the legs fully retracted; there must be a **minimum** clearance from the bottom of the foot to the ground of **300mm**.
4. For the FW37 and the KH22 the square connection tube between the geared and the slave leg (item 6) must be cut to size. The correct length must ensure that no lateral pressure is applied to the drive shafts of the geared and slave leg in the fully installed position (no bolts required).
5. For the KH25 the round connection tube is bolted on to the drive and driven shafts.



6. Before installing the connection tube (item 6), adjust the foot elevation on the geared and the slave leg to be 0- 5mm of each other.
7. Install M16 bolts (Min Grade 8) through all the mounting holes and torque them to 190-210Nm.
8. Install bracing as suggested in Fig B. as well as a crank handle clip.

INSTALLATION, MAINTENANCE & SERVICE BULLETIN

Operation

1. Lower the feet to the ground by engaging the high gear. The high gear is selected by pulling the crank handle outwards. Make sure to engage the high gear properly by rotating the crank handle while pulling on the handle at the same time. **NOTE:** Only operate landing legs with the prime mover and trailer park brakes engaged.
2. When the feet contact the ground, push the crank handle inwards and select low gear. Use the low gear and rotate the crank handle 4-8 turns to fully support the trailer.
NOTE: Use low gear ONLY, when the legs are under any type of load.
NOTE: The landing legs should only be lowered on level and solid ground.
NOTE: Do not change gears under load.
3. Do not wind the legs out to the maximum height as it might over stroke. If extra height is required use a spacer block under the feet.
4. After the trailer is hooked up and the landing legs are **fully** retracted, push the crank handle and shaft inwards **engaging low gear** and now secure the crank handle on the crank handle clip.

Maintenance and Lubrication

1. Check all fasteners.
2. Check for any excess wear on the feet. **Note: Go to point 6 for G-Foot replacement**
3. Check for any cracking or bending of the landing leg bracing.

4. Lube all grease nipples with a good quality lithium based grease at the same frequency as all the other grease points on the trailer.



5. Periodically (annually) remove the plastic cover and check (replace) the grease in the gearbox.



INSTALLATION, MAINTENANCE & SERVICE BULLETIN

6. G-Foot replacement

The G-Foot replacement Kit part number is:

KH200015G

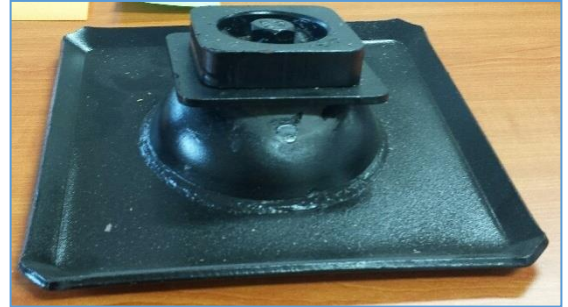

- a. Grind off the weld connection of the old foot to the main landing leg body.

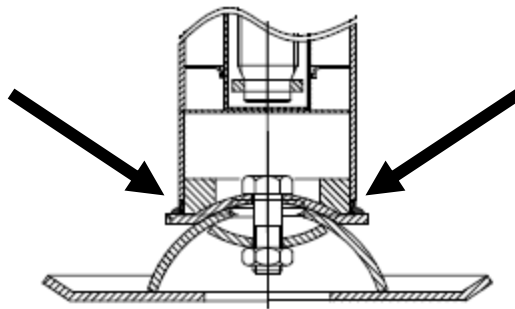

- b. Remove the old foot assembly and clean up the edge of the bottom end of the square tube.
c. Insert the new G-Foot replacement kit and weld the foot flange to the square tube.

