

# INSTALLATION, MAINTENANCE & SERVICE BULLETIN

## UNITIZED WHEEL BEARING HUB

The FKH unitized wheel bearing hub, is fitted with an SKF bearing cartridge. This bearing cartridge is sealed and is not serviceable (not adjustable nor grease able).

While the unitized hub offers reduced maintenance (the bearing cannot be adjusted or re-lubed), it still requires regular inspections / checks and monitoring, particular in off-road applications and towards the end of the bearing's service life.

The unitized hub can be identified from the hubcap:

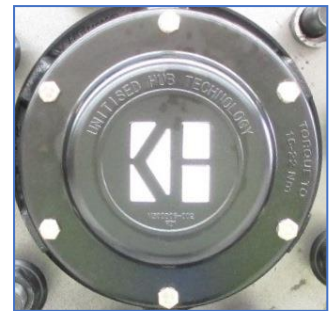

And when removing the hub cap, you will see the sealed bearing cartridge. No grease and/or bearing rollers are visible.

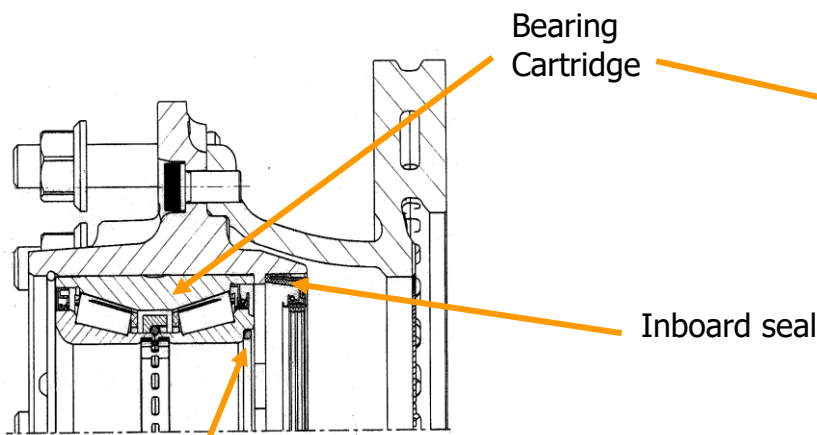

The O-Ring is on the bearings inboard side.



# INSTALLATION, MAINTENANCE & SERVICE BULLETIN

## 1. Vehicle Inspection

### 1.1 Interval

Normal Duty Operation - Inspect the wheel end every 200,000kms or 12 months, whichever comes first.

Heavy Duty Operation - Inspect the wheel end every 100,000kms or 6 months, whichever comes first.

Note: The above Intervals may need to be reduced depending to the conditions of the application and/or towards the end of the bearing life.

## 2. Wheel End Inspection

### On the Road:

After a period of driving (when checking the tyres), a heat gun is extremely useful to compare the running temperature of all the hubs. A bearing which is running comparatively hotter needs to be checked in the workshop as soon as possible.

### In the Workshop:

Go first to 2.2 for details on the noise check and then to 2.3 for endplay check.

Also check for signs of excessive seal leaks, go to 2.1 for the details.

### 2.1 Checking the Seals:

1. Remove the hubcaps and check the outer wheel bearing seals for signs of lube leakage. A small amount of lube may be visible at this seal, this is a normal occurrence. However if a large amount of grease is visible (see photo below), the bearing should be replaced. If you are unsure, take a photo and check with FKH, before going any further.



This seal is OK



This seal is leaking – Replace the Bearing!



## INSTALLATION, MAINTENANCE & SERVICE BULLETIN

2. Check the additional inboard seal for leakage and wear. Road dust may dry out the inboard seal and it will subsequently no longer protect the actual inner bearing seal as well. Keep the Inboard seal in good condition. Always replace the inboard seal when the hub has been removed.
3. Check the O-Ring in the hub cap for splits or cracks. Replace if required.

### 2.2 Checking Smooth Rotation and Bearing endplay:

1. Secure the trailer; jack up the axle, release the brakes, rotate the hub and wheel assembly.
2. Listen for any audible sounds coming from the wheel bearing while the hub and wheel assembly is rotated. If any noise can be detected, remove the wheels and brake drums and check it again. **Replace any noisy wheel bearings.**
3. If there are no noises emanating from the bearing, check if any lateral wheel bearing movement can be detected. If there is no endplay, reassemble the hub cap. Check complete.  
If you do feel endplay, go to 2.3.

### 2.3 Bearing endplay checking Procedure:

1. Check the bearing endplay:
  - a. Remove the wheels and brake drum.
  - b. Hub cap has already been removed.
  - c. Bend the two lock tabs back and unlock the nut.
  - d. While rotating the hub, tighten the castellated nut to 950Nm (700lb/ft).
  - e. Check if endplay has been eliminated by using a dial indicator.
  - f. If the dial indicator reading is more than 0.005" (0.127mm), **replace the bearing!**
  - g. If the endplay is less than 0.005" (0.127mm), bend two new lock tabs down relocking the nut again. Following by reassembling the brake drum, wheels and hub cap. Check completed.

Note: Go to page 6 for special nut socket to help achieve the 950Nm (700lb/ft).

## INSTALLATION, MAINTENANCE & SERVICE BULLETIN

### 3. Removing the hub.

Following standard procedures to remove tyre and wheel rim depending on wheel rim used, ensure that all safety requirements are followed.

1. Ensure the hub weight is securely held to support its weight when hub is removed from axle.
2. Remove six hubcap bolts and hubcap.
3. Open the tabs on lock tab washer. (Scrap the used lock tab washer)
4. Remove the castellated nut and thrust washer.
5. Hold the hub with both hands and pull the hub as straight as possible.  
If the hub is not moving by hand, then use a hub - bearing puller.

Note: Whenever the hub has been removed a new inboard seal must be installed! See hub installation procedure for all the details.

FKH unitised hub puller: KH1007-001



Other hub puller designs

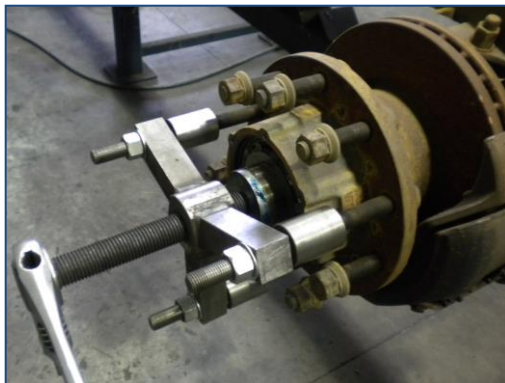

# INSTALLATION, MAINTENANCE & SERVICE BULLETIN

## 4. Hub installation Procedure

Do not try and assemble the hub with wheel and rim attached.

The additional inboard seal (see Figure 1 on page 6) must be replaced each time the hub is removed (see section 5 for part number details for that seal).

1. Using a clean rag, clean the hub bore and axle spindle.
2. Check the axle spindle, hub bore, and axle spindle shoulder for scratches, burrs and any surface imperfection. If required use emery paper to repair. Clean again after using the emery paper.
3. Inspect the thread and nut, clean & lubricate both and run the nut up the full length of the thread to ensure it is free and not affected by high spots.
4. Check if the Seal Shield is installed (disc axle only). Earlier disc axle models have not been fitted with that. The Seal Shield adds protection to the inboard seal.

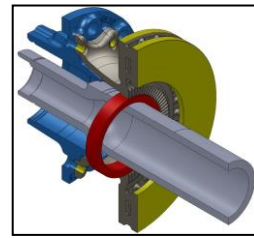

Part number of the Seal Shield is: N300200-002

Install the Seal Shield level with the cast pulse ring on the disc rotor.

5. Apply a good film of Anti-frett paste (Available from SKF, P/N: LGAF 3E/05 > 0.5kg or LGAF 3E/30 > 30kg, or Fuchs-Lube "Gleitmo" 805 in 500gr tube P/N: BTH-AFG) to the entire bore of the bearing unit, including the O-Ring on the inboard side of the bore.



## INSTALLATION, MAINTENANCE & SERVICE BULLETIN

6. To ensure proper seal life of the additional inboard seal, add approx. 30-40gr of Mobilith SHC007 (Synthetic Semi fluid grease) to the inside seal cavity.

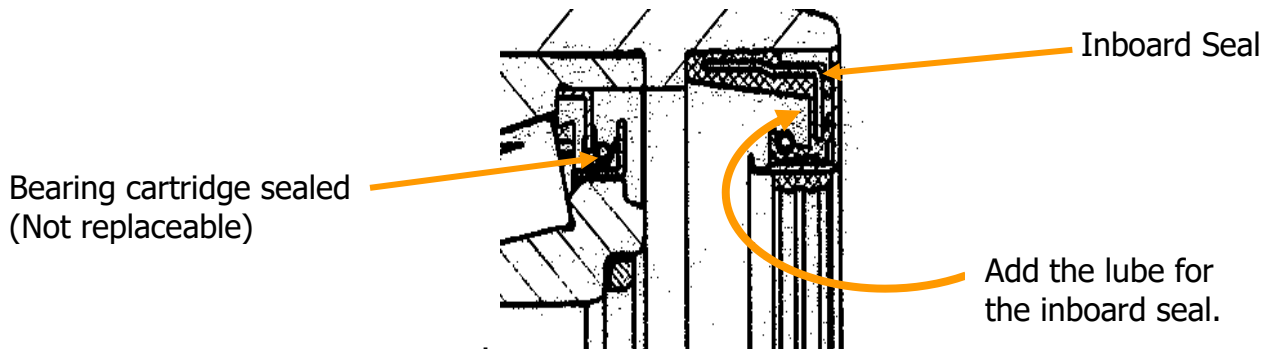

Figure 1

7. Take time to carefully align the hub bore with the axle spindle, and slide the hub straight on. If the hub jams, remove the hub repeat installation taking additional care aligning the hub. Do not force the hub if it jams.
8. Install the thrust washer, install a **new** lock tab washer and install the castellated nut with the thrust face lightly lubricate with grease. **ALLWAYS** use a new lock tab washer!
  - a. If the castellated nut is replaced with "Stemco Pro-Torq" nut, do not install the thrust washer and the lock tab washer.
9. Torque the nut **to 950Nm (700 lb/ft)**, while rotating the hub a minimum of 10 times. **Note:** Ensure the proper socket (torque wrench, torque multiplier) is use to achieve the required nut torque.



FKX Socket: 1011-001 for 11t axle  
 1011-002 for 9t axle

10. Fold at least two of the tabs on the lock tab washer over the nut to lock the nut in position.
11. Ensure the hub rotates freely, and measure the bearing endplay as per section 2.3.

# INSTALLATION, MAINTENANCE & SERVICE BULLETIN

12. Check hubcap and hubcap mating surfaces are free of dirt and burrs. Check the O-Ring for splits or cracks, replace O-ring if damaged. Lightly grease the O-Ring before installing hubcap. Lock washers of the split, conical or internal toothed design may be used in conjunction with the fastening bolts (do not use flat washers). Thread all bolts loosely, and then tighten down uniformly in a star pattern with 16 to 22 Nm.

## 5. Replacing the additional inboard seal.

**NOTE:** The additional inboard seal must be replaced each time the hub is removed!

Note: Be careful not to confuse the additional seal with the inner and outer seals of the cartridge bearing, these seals are not replaceable (see Figure 1).

Please check the FKH axle Parts View for the correct part number for the correct inboard seal for the given axles.

1. Remove the old seal using a seal removal tool (SRT-1). If this tool is not used, ensure the end of the cartridge bearing is protected by placing a plate over the end of the bearing.
2. Check the hub bore is clean and free of any scratches and burrs.
3. Install the seal with recommended seal installation tool (Depending which seal is used). Ensure the seal is evenly seated and bottomed out in the bore. As in any seal installation, apply an even driving force to avoid cocking the seal or damaging the flange surface. Replace the seal if it is cocked or damaged during installation.
4. To ensure proper seal life of the additional inboard seal, add approx. 30-40gr of Mobilith SHC007 (Synthetic Semi fluid grease) to the inside seal cavity.



**Note:** There is a FKH Unitized Hub Installation Wall Chart available.

The part number for 1lt of SHC007 is: **133680-1L**