

KT AIR SUSPENSION

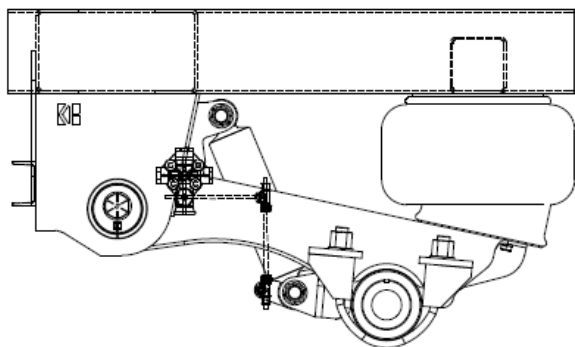

KT 250 T
KT 300 T

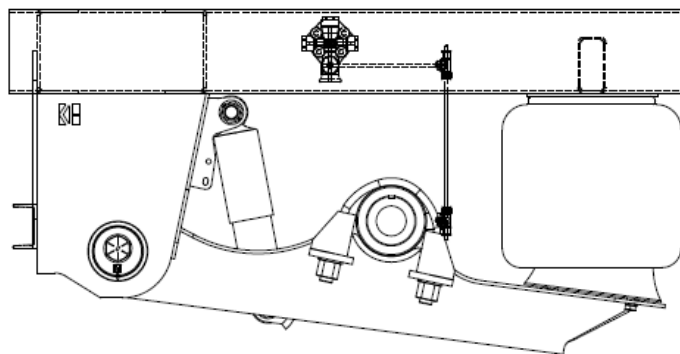

KT 250 U
KT 300 U

Note: For parts identification go to the FKH Parts View Bulletin KPS-001-1112 on www.khitch.com.au

Contents

- 1. Tightening Instruction**
- 2. Pivot bolt and trailing arm bush**
- 3. HCV settings**
- 4. Axle Alignment**
- 5. Torque Decal**
- 6. Maintenance**

1. Tightening Instruction

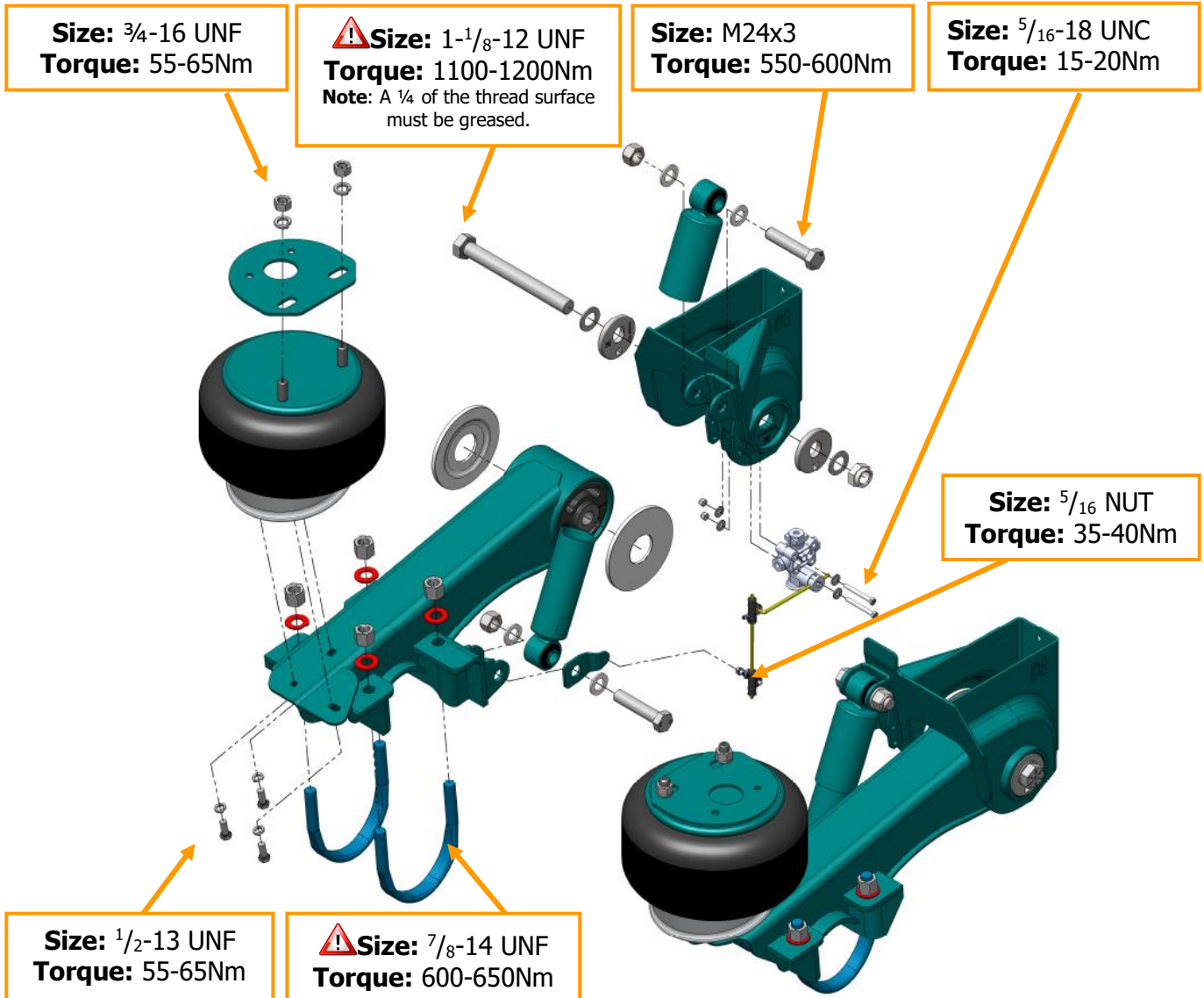

⚠️ IMPORTANT:

- Shock absorber & hanger pivot bolts must be tightened at ride height.
- U-bolts must be tightened and torqued using a cross pattern sequence. Ensure equal amounts of thread protrude above U-bolt nut.

⚠️ CAUTION:

- Over torque could result in fastener failure.
- Failure to follow properly torque can result in loss warranty coverage.

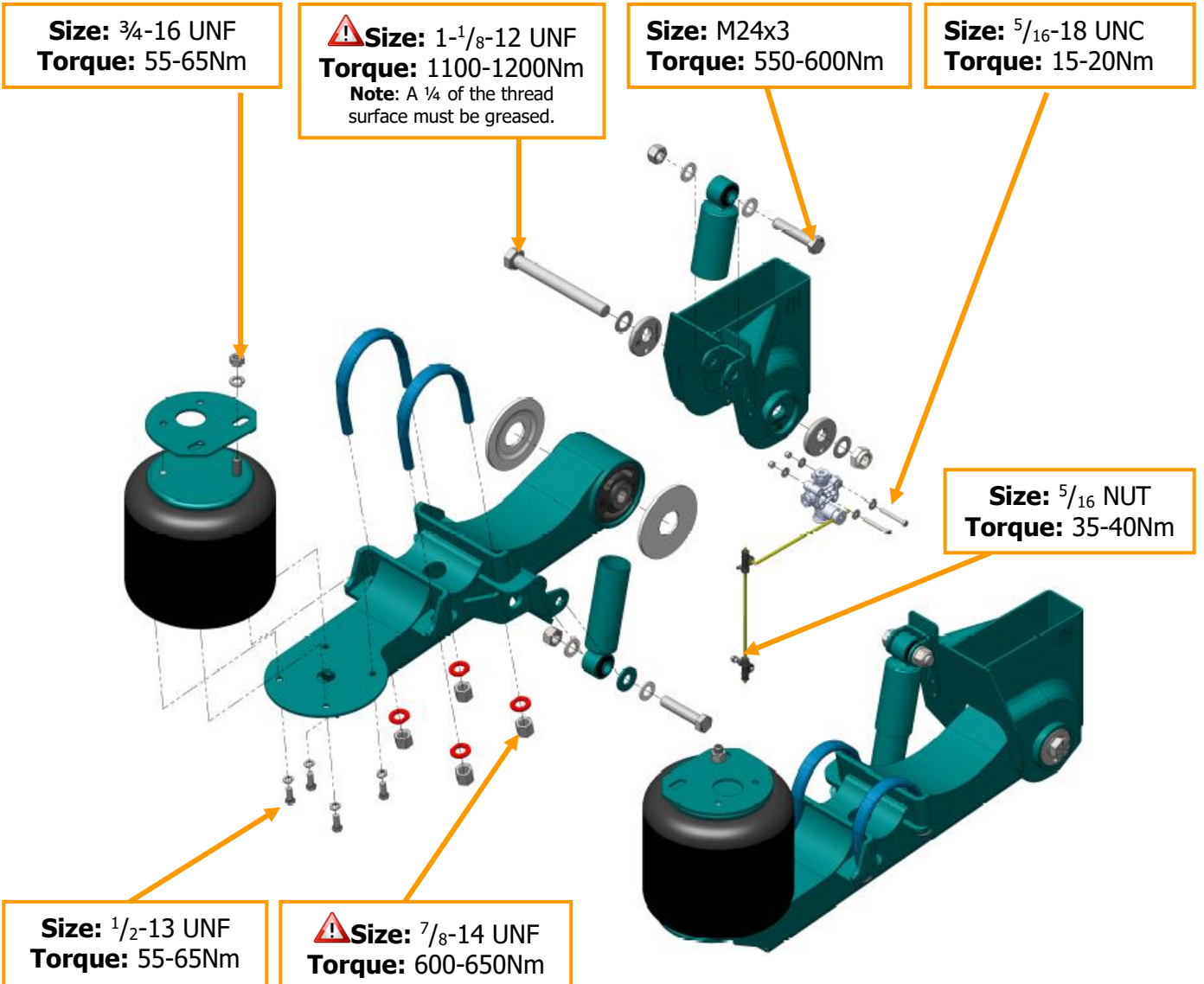

⚠ IMPORTANT:

- Shock absorber & hanger pivot bolts must be tightened at ride height.
- U-bolts must be tightened and torqued using a cross pattern sequence. Ensure equal amounts of thread protrude above U-bolt nut.

⚠ CAUTION:

- Over torque could result in fastener failure.
- Failure to follow properly torque can result in loss warranty coverage.

MAINTENANCE & SERVICE BULLETIN

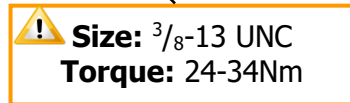
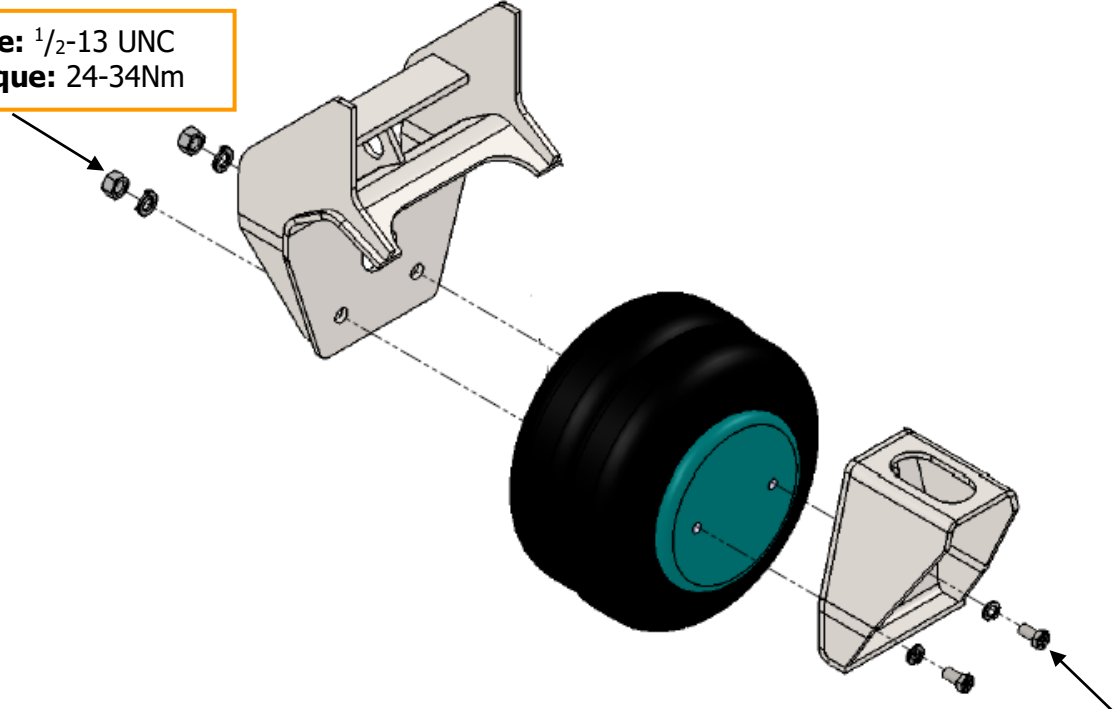
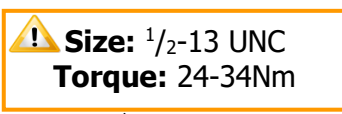
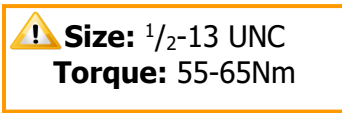
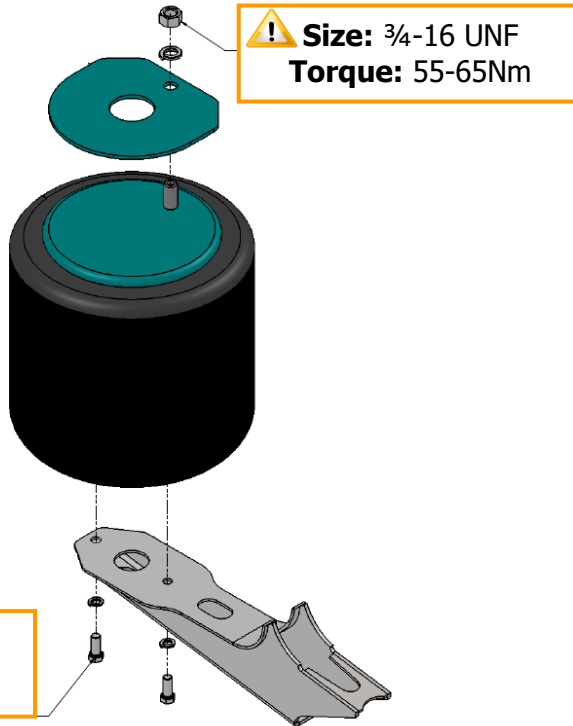

! CAUTION:

- Over torque could result in fastener failure.
- Failure to follow properly torque can result in loss warranty coverage.

2. Pivot Bolt and Trailing Arm Bush

Inner & Outer Collar square holes must line up inside to outside

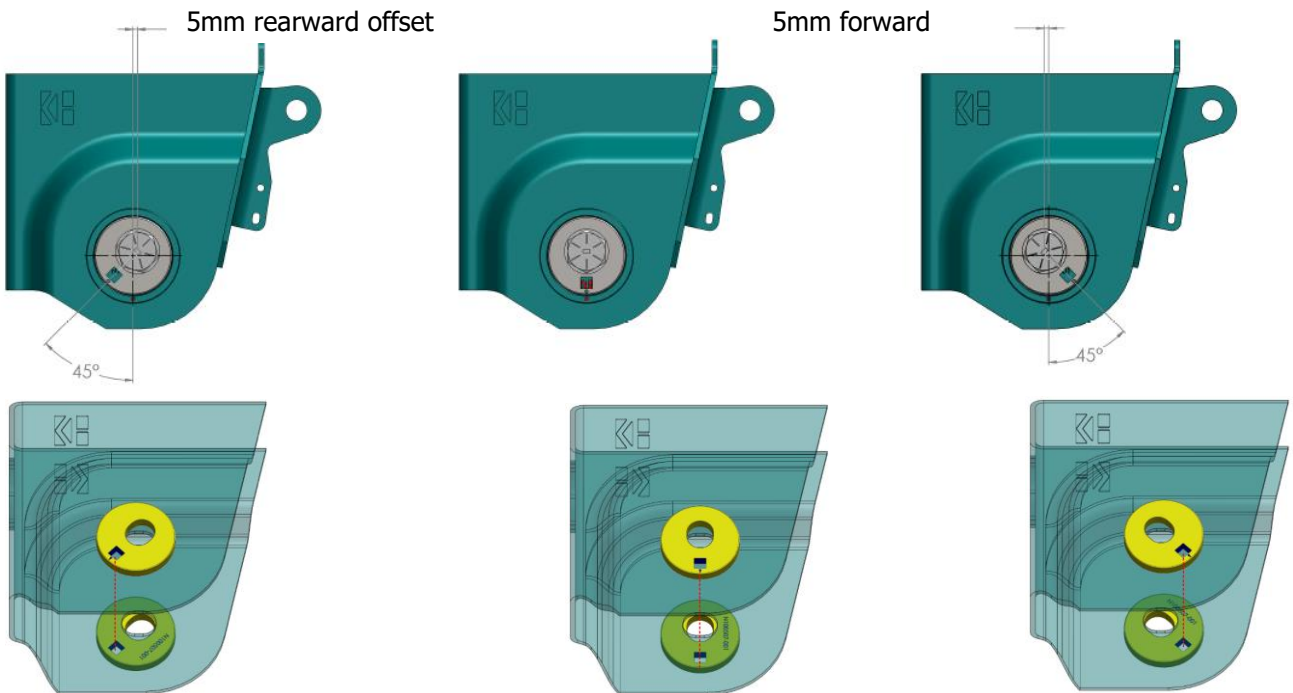
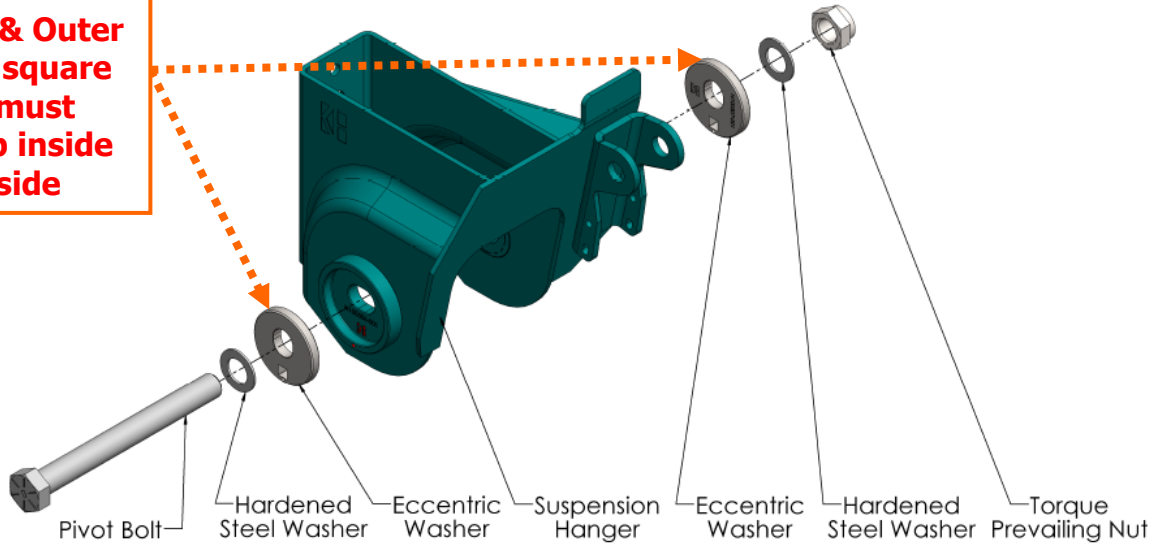

! IMPORTANT:

- Do not fully torque up pivot bolt until suspension is fully aligned. Before alignment, tighten up pivot bolt to a point where hardened washers can still rotate freely.
- Adjust all four eccentric collars to achieve suspension alignment

Trailing Arm Bush

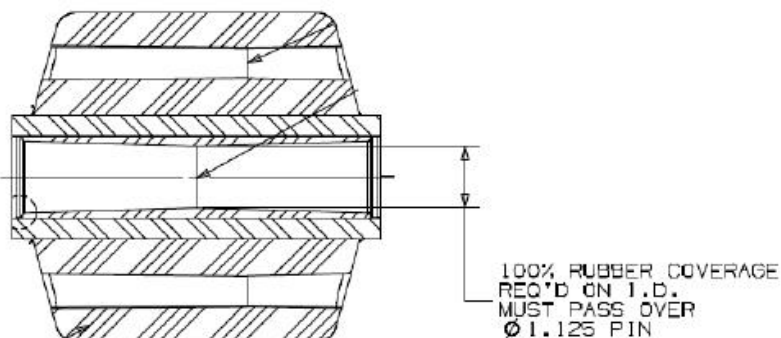

The $\text{Ø } 1 - 1/8''$ bolt should be tight in the centre of the sleeve and have a gap at each end of the sleeve.

The reason for that is that the rubber coating on the inside of the sleeve tapers from the middle at a little less than $\text{Ø } 1-1/8''$ out to approx. $\text{Ø } 1- 5/16''$ at each end.

The purpose of the tapered inside rubber coating is, to prevent the steel bush rusting to the hanger pivot bolt.

The bush (and the connected trailing arm) is securely locked in to position after the hanger pivot bolt is tightened to the required torque of 1100-1200Nm.

Note: There are other brands of trailing arm bushes (aftermarket replacement parts etc) which do not have the internal rubber coating in the steel bush.

Checking the trailing arm bush in the installed position

The trailing arm bush will wear over time and the following information will help to identify when the bush needs to be closely inspected* without removing the pivot bolt.

*A close inspection will require the pivot bolt to be removed and lower the trailing arm

As the bush wears (collapses) the trailing arm will move further up in to the hanger. Therefore a measurement can be taken to determine if the amount of movement exceeds the normal running condition.

MAINTENANCE & SERVICE BULLETIN

The tools required are a simple adjustable steel square and a steel ruler.



Dimension X:

Trailer Unloaded

X = 25mm or more = OK

Note: A loaded trailer will compress the bush and **X** will be smaller.

Compare the dimension **X** between all the 6 hangers (on tri suspension) and it may show a badly worn bush as the odd dimension out.

*Close inspection

New Bush:
 no cracks
 no rubber to steel separation.

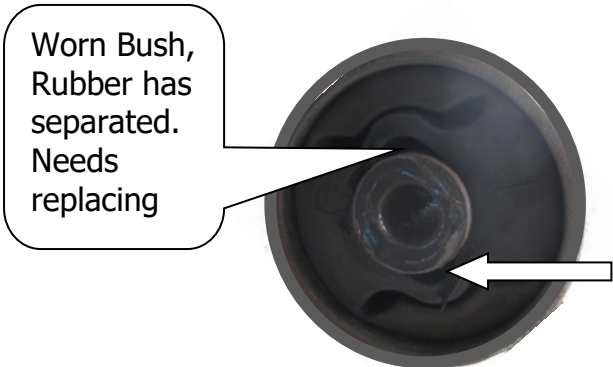
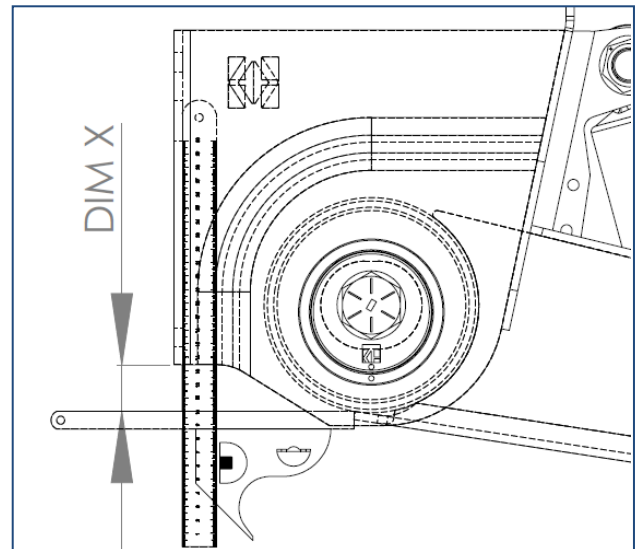

3. HCV Setting

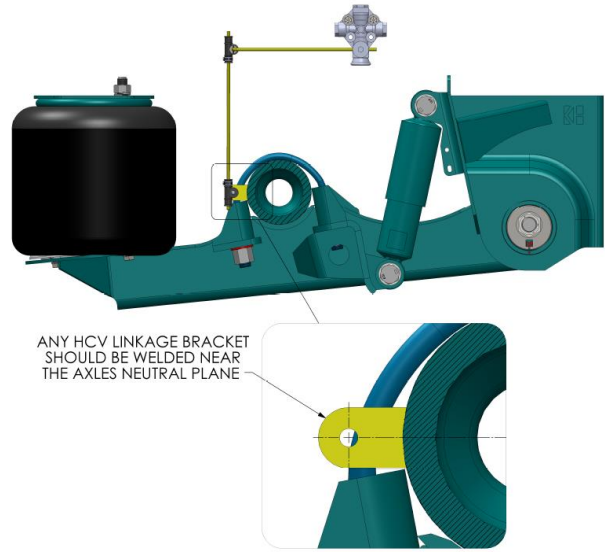
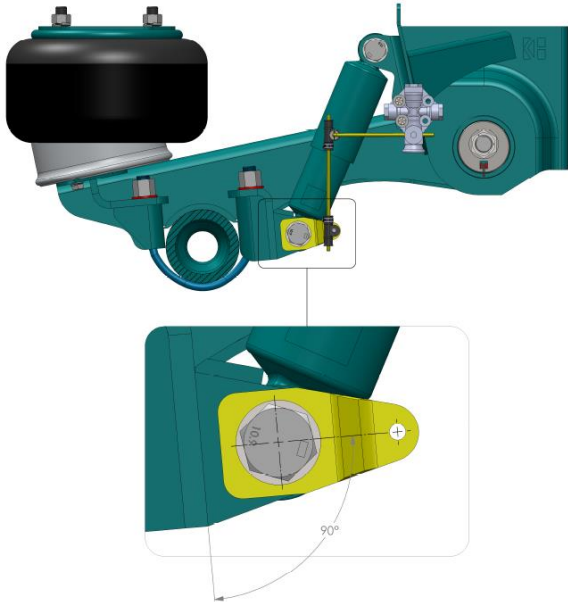

Overslung at ride height.

Underslung at ride height.

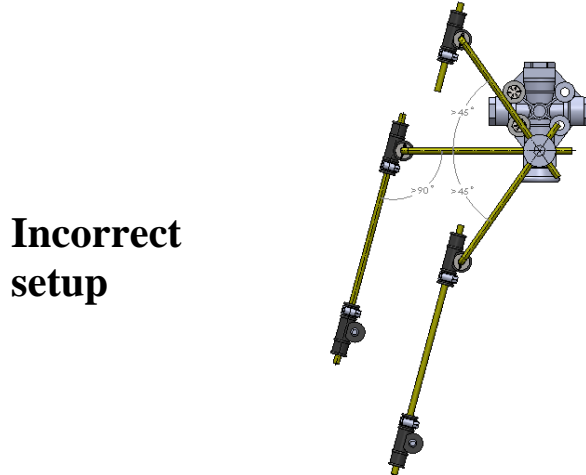
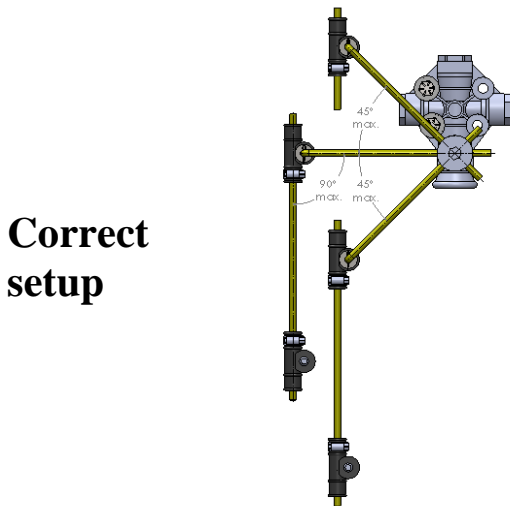

! IMPORTANT:

- HCV can be used in right-hand or left-hand.
- Unless approved by Fuwa K Hitch, DO NOT use more than one HCV per trailer.
- When assembling air fittings, be mindful that excess pipe sealant compound or Teflon tape may contaminate and block the air system.

4. Axle Alignment

The following steps are to ensure that proper axle and suspension alignment is achieved.

- The trailer must be in straight line and on smooth level surface.
- Release the brakes.
- Check that the tyres are the same size and have equal inflation pressure.
- Set the suspension to the correct ride height.
- Align all axles within the tolerances shown in Fig. A.
- Torque the hanger pivot bolt to 1100-1200Nm.
- Re-check the alignment at the 1st Service (5000-10000Km or 2-4 weeks)

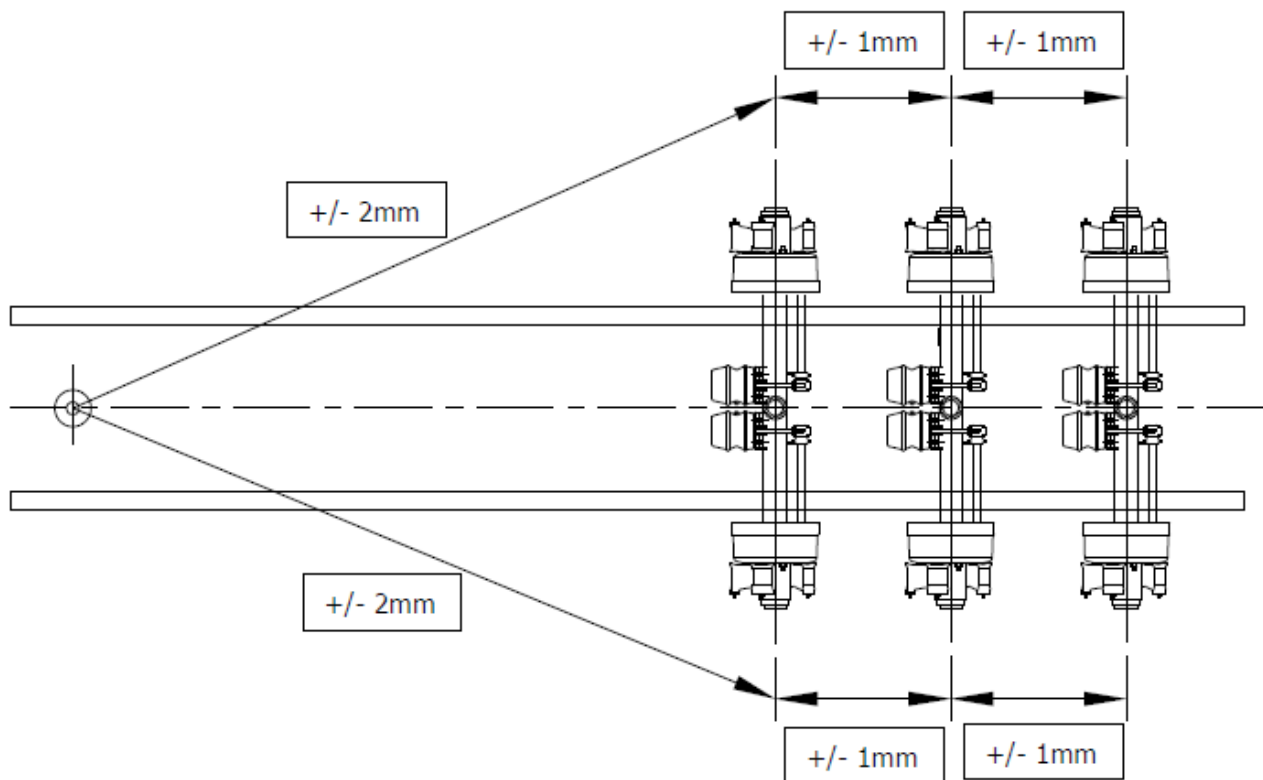



Fig A

FUWA Axles are manufactured to a Toe-in / Toe-out tolerance of +/- 0.8mm/m.

Note: No adverse affects should be experienced with Toe-in/Toe-out up to +/- 1.6mm/m

5. Torque Decal

	TORQUE REQUIREMENTS	
	Hanger Pivot Bolt	1-1/8"-12 UNF 1100-1200Nm
	Shock Bolt (upper & lower)	M24x3 550-600Nm
	U-Bolt	7/8"-14 UNF 600-650Nm
	Air Spring Nut (upper)	3/4"-16 UNF 55-65Nm
Air Spring Nut (lower)	1/2"-13 UNF 35-45Nm	

Note: A ¼ of the thread surface must be greased.

U-Bolts must be tightened & torqued using a cross pattern sequence: 1-4-2-3



Service Intervals
 1st Service: 5000-10000kms or 2-4 weeks
 there after
 Every 100,000kms or
 every 50,000kms for heavy duty applications

www.khitch.com.au FHDT-001-Rev 1

The above Torque Decal (Sticker) should be attached to the trailer chassis after it has been painted. It should be close to the Chassis Vin number Decal clearly accessible and visible.

6. Maintenance

The maintenance frequency may need to be changed subject to the application and vehicle operating conditions.

Any instructions from the vehicle OEM must be considered first.

- | | | | |
|---|----|-------------------------|----------|
| 1. Check all the fasteners | PD | 1 st Service | ½ yearly |
| 2. Check pivot bolts, shocker bolts & U-bolts | PD | 1 st Service | Annually |
| 3. Check shock absorbers* and shocker bushes | | 1 st Service | Annually |
| 4. Check HCV for leaks and correct adjustment | | 1 st Service | Annually |
| 5. Check trailing arm bush and hanger wear pads for wear and excess movement. | | | Annually |
| 6. Check air springs for leaks or damage. | | 1 st Service | Annually |

Note: The above recommendations are for “On HWY only” applications.

Note: * In regards to shock absorbers “leaking”. Do not confuse “misting” and “sweating” with leaking.

Only a leaking shock absorber (oil running down the length of the shocker body) needs to be replaced.

If in doubt, clean the shock absorber and check it again after a few days.

Shock absorbers are a wearing item and they will need replacing.



If you need any further information, please call FKH or go to the FKH web site.