

# INSTALLATION, MAINTENANCE & SERVICE BULLETIN

## MECHANICAL SUSPENSIONS



1. Safety Procedures and General Information
2. Installation
3. Lube
4. Suspension Alignment
5. Maintenance
6. Torque Chart
7. Trouble Shooting

Note: This bulletin may be required together with the axle welding information bulletins (see page 6).

# INSTALLATION, MAINTENANCE & SERVICE BULLETIN

## **1. Safety Procedures and General Information**

### 1.1 Safety First

Be sure to read and follow all installation and maintenance procedures.

### 1.2 Lifting

Practice safe lifting procedures. Consider size, shape and weight of assemblies. Obtain help or assistance of a crane and licensed operator when lifting heavy assemblies. Make sure the path of travel is unobstructed before lifting or moving an assembly. Always wear appropriate safety clothing and equipment to prevent injury in the event of an accident.

### 1.3 Welding

When welding, be sure to wear all personal protective equipment for face and eyes. Ensure that the work area has adequate ventilation and visual protection for passers-by. When welding, protect the spring beams and air springs from weld spatter and grinder sparks. Do not attach "ground" connections to springs.

Under normal use, steel presents few health hazards. However, prolonged or repeated breathing of iron oxide fumes produced during welding may cause bad health.

### 1.4 Overloading

Overloading is the practice of transporting a load that exceeds the design specified ratings of that vehicle. Overloading can cause component failure resulting in accidents.

# INSTALLATION, MAINTENANCE & SERVICE BULLETIN

## 2. Installation

### 2.1 Suspension mounting to the trailer frame - Slope Considerations!

Investigations into the performance of trailers fitted with more than one axle suspension, have shown that installation is critical in regards to trailer/chassis slope.

High axle loadings due to excessive slope and therefore incorrect load sharing can result in excessive tyre and component wear (worn out rocker boxes, tyre vibrations). Therefore, it is imperative that when installing a suspension system that particular attention is paid to the trailer slope in laden condition.

The mounting position of the suspension to the trailer when under load must not deviate by more than  $\pm 0.5^\circ$  (as per FKH installation drawing and ADR) when measured horizontally along the length of the trailer from back to front.

It is highly desirable to keep the tolerance  $+0.5^\circ$  to  $-0.0^\circ$ , as a downward slope may cause some functional issues (rear axle vibrations).

Frame deflection under load, must also be considered as it will result in additional downward slope!

If the trailer slope in the laden condition exceeds this maximum deviation, the travel and position of the equalizers (rocker boxes) is affected and the axle loads will be unequal.

Travel direction 

Fig1

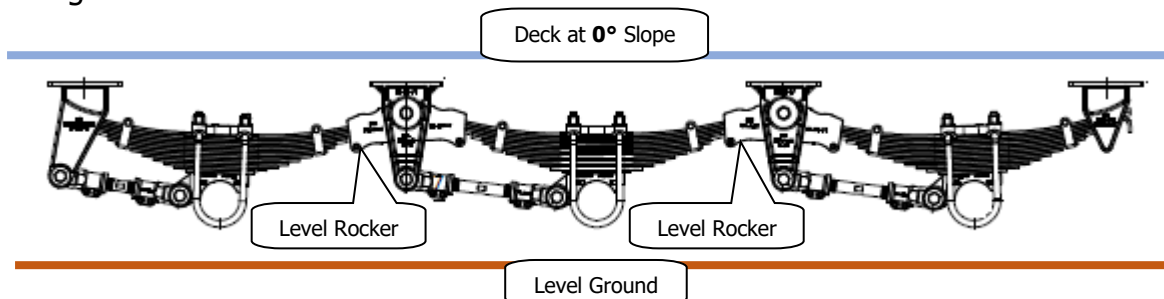

Condition: Ideal as deck, hanger mounting surface and ground are all parallel to each other.  
 Consequence: Equal load on all axles.

# INSTALLATION, MAINTENANCE & SERVICE BULLETIN

Fig2

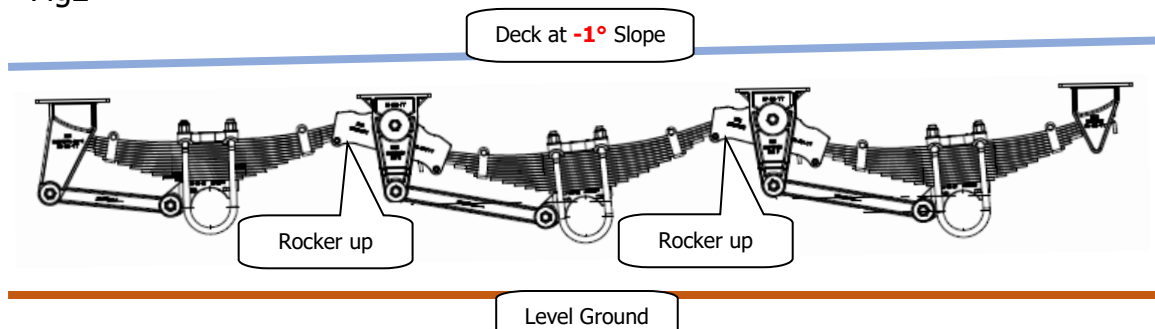

Condition: Deck and hanger surface sloping downwards.  
 Consequence: 1st axle high load, 2<sup>nd</sup> axle medium load, 3<sup>rd</sup> axle low load.  
 What to do: Lift the 5<sup>th</sup> wheel. If that is not possible space the rear hangers (2,3,4) to the chassis.

Fig3

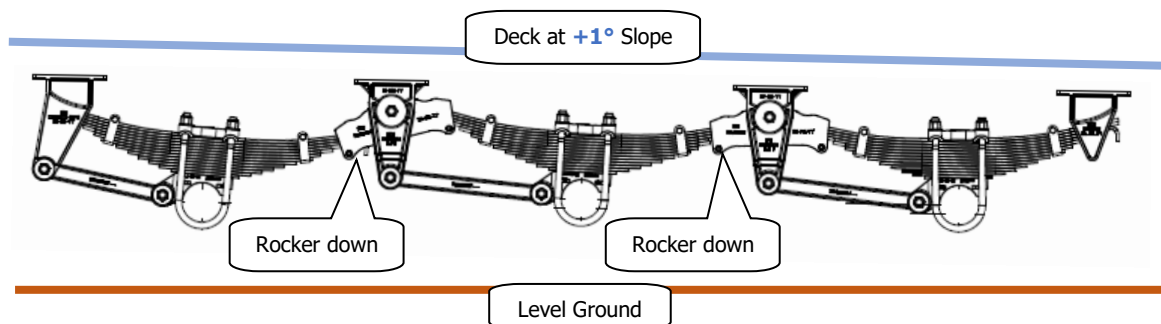

Condition: Deck and hanger surface sloping upwards.  
 Consequence: 1st axle low load, 2<sup>nd</sup> axle medium load, 3<sup>rd</sup> axle high load.  
 What to do: Lower the 5<sup>th</sup> wheel. If that is not possible space the front hangers (1,2,3) to the chassis.

## 2.2 Hanger Installation

Determine the centre to centre dimensions of the hangers for your suspension system based on the appropriate FKH technical installation drawing.

Tack weld the hangers in place, ensuring that the hangers are square on the chassis and that the hangers line up along the chassis rails (within 1.5mm)

**NOTE:** For all suspension systems, the radius rod hole on the front hanger must face forward, while the radius rod hole(s) on the equalizer(s) must face rearward.

# INSTALLATION, MAINTENANCE & SERVICE BULLETIN

Check the diagonal distances between all the hangers i.e. Front Hangers, Equalizer Hangers, and Rear Hangers. These measurements must be within  $\pm 3\text{mm}$  as shown on the technical drawings.

If these measurements are correct, insert a steel pipe cross brace through the holes on the hangers as shown in figure 2.1.a.

For 13, 17 and 20ton suspension, add bracing to the hangers as shown in figure 2.1.b.

Once the pipes are in place, the operator can commence fully welding the hangers in to place.

Hanger bracing should be considered for all suspensions, especially when the trailer is operating in off road conditions (loading or unloading).

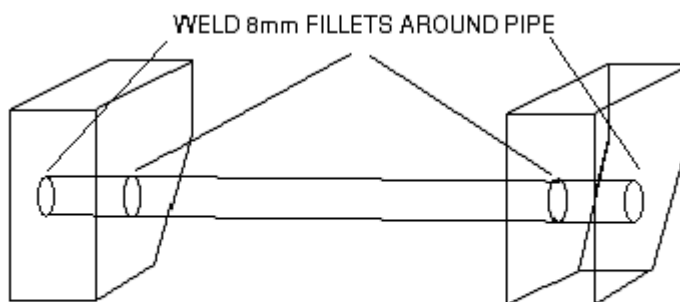

**NOTE: IF PIPES INTERFERE WITH MOVEMENT OF ROCKERS, CUT PIPE SO THAT THERE IS NO PROTRUSION INTO HANGERS AND FULLY WELD TO INSIDE OF HANGERS**

Figure 2.1.a – Pipe installation (min. 5mm wall)

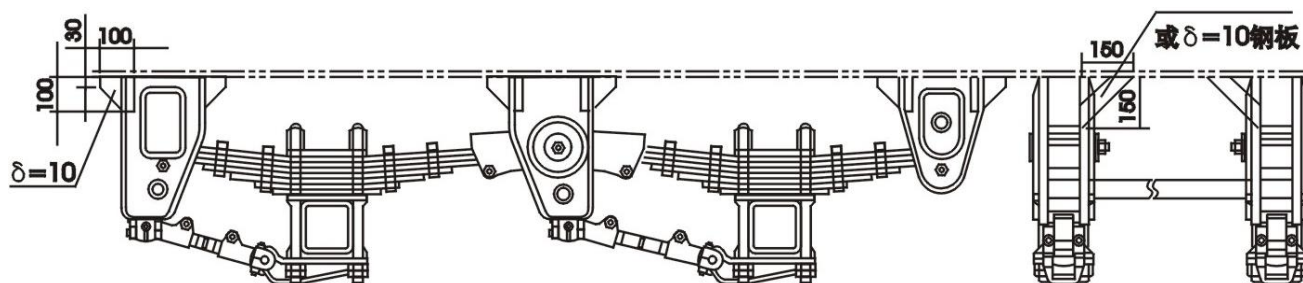
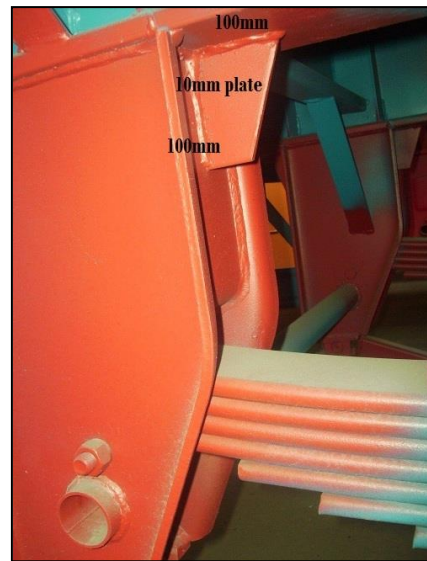
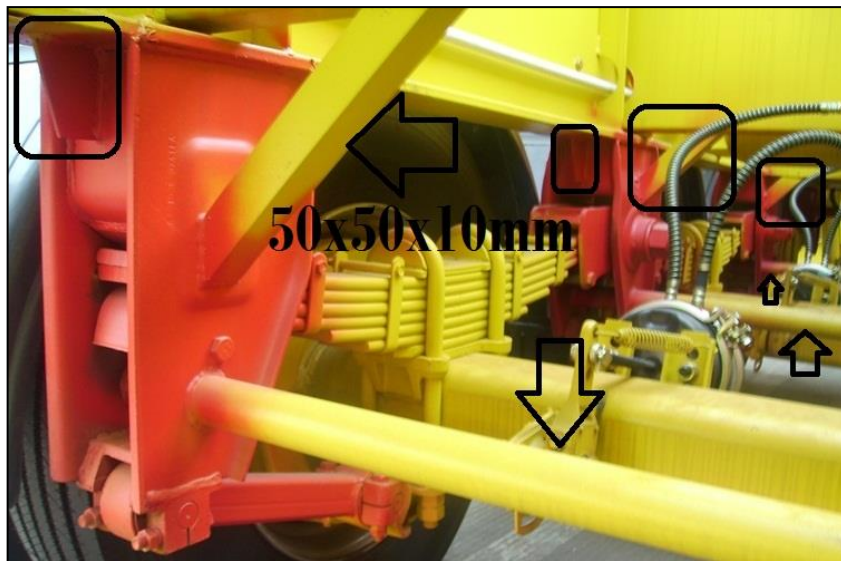

Figure 2.1.b

## INSTALLATION, MAINTENANCE & SERVICE BULLETIN



### 2.2.1 Welding instructions for welding hangers to chassis

Tack weld the hanger in to position and after checking the position again, weld all around the top of the hanger with a 10mm continuous fillet weld.

(Add bracing to 13,17 and 20ton suspension – see Figure 2.1.b)

For optimum results we recommend the customer use ESAB 7018 or low hydrogen welding rod or equivalent.

### 2.3 Axle / spring seat installation and welding

Note: All axles must be installed so the cam shaft rotates in the same direction as the wheels during forward operation.

Position the axle seats on the axle at the correct spring spacing as per the width of the hanger centres on the chassis. Centre of each bolt hole must be at top centre of axle for overslung suspensions and bottom centre for underslung suspensions. Ensure that the seats are parallel with each other as well as being parallel with the ground. Clamp the seats in place and tack weld.

# INSTALLATION, MAINTENANCE & SERVICE BULLETIN

## Ø127mm Round Axle

(11t cast suspension)

**Overslung** (spring is on top of the axle)

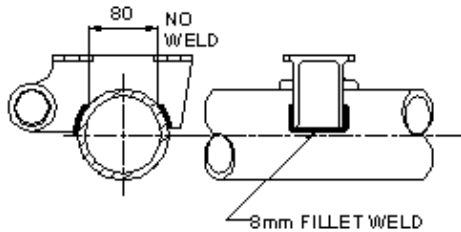

**Underslung** (spring is below the axle)

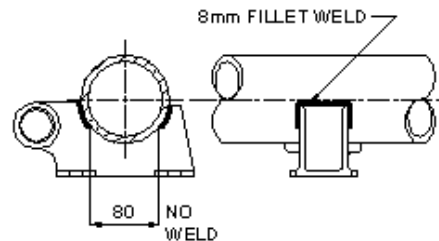

## 150x150mm Square Axle

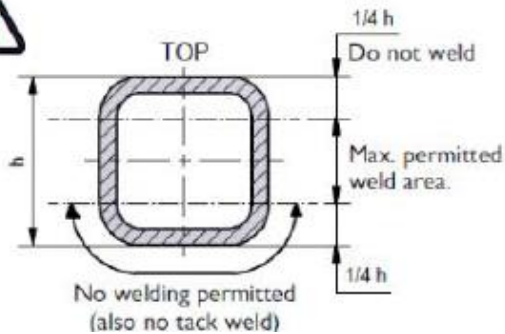

Press to attach axle beam as close as possible

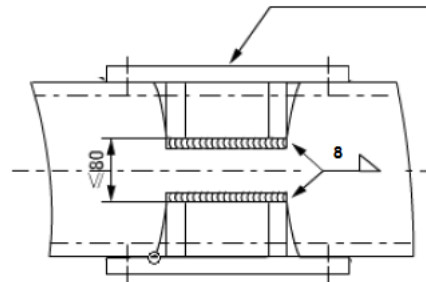

**Overslung** (spring is on top of the axle)

11t cast suspension: TR Brkt. Is on top of the axle

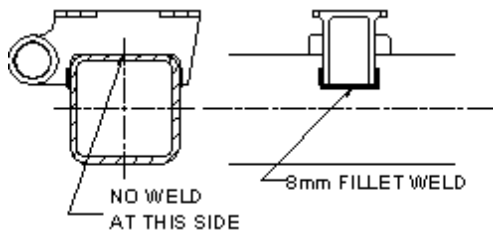

**Underslung** (spring is below the axle)

11t, 13t, 17t, 20t: TR Brkt is below the axle

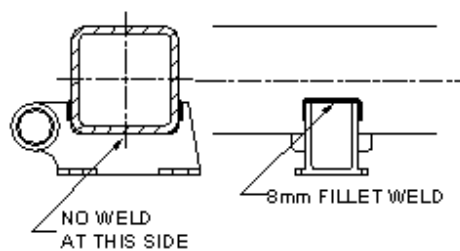

13t, 17t, 20t: TR Brkt. Is below the axle

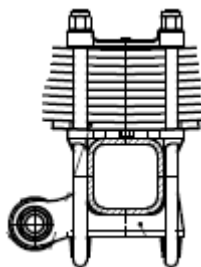

Welding requires 8mm fillet welds. For optimized results we recommend the use of low hydrogen electrodes or MIG process.

**NOTE:** When welding any FKH mechanical suspensions to any FKH axles, check the "Welding to the FKH Axle" bulletin **KPM-001-0310**.

When welding any FKH mechanical suspensions to any other axle brand, check the welding instruction from that axle manufacturer.

# INSTALLATION, MAINTENANCE & SERVICE BULLETIN

The welding rod must generate tension test strength of 70,000psi. Normal methods and electrode classifications are shown in table 2.4.1. To obtain the best fusion and the strongest weld use the voltage and current settings recommended by the electrode manufacturer.

METHOD FOR WELDING CARBON & LOW ALLOY STEEL	AWS* ELECTRODE CLASSIFICATION	AWS SPEC.
Shielded Metal Arc	E70XX	A5.1, A5.5
Gas Metal Arc	ER70S-X	A5.18
Gas Tungsten Arc	ER70S-X	A5.18
Flux Cored Arc	E70T-X	A5.20

Table

The maximum weld bead size permitted, regardless of the number of passes, is 9.5mm on rectangular axles and 12.7mm on round axles.

Excessive welding to the axle should be avoided. Fitting the attaching parts as neatly as possible to the axle will help reduce excess welding.

Complete required welds using the least number of passes and if multiple passes are used, thoroughly clean the weld between passes.

Weld beginnings and ends should be performed as shown in Fig 2.4.2.

- The weld arc should not be started at either end of the bead. Instead the electrode should be started away from the ends of the bead as shown.
- The weld arc should not be finished at either end of the bead. Again the electrode should be finished away from the ends of the bead as shown. Any craters that remain should be filled during this movement.
- In both cases, the intention is to remove stress increasing operations, such as the starting and ending of an arc, from high stress areas such as the ends of the welds

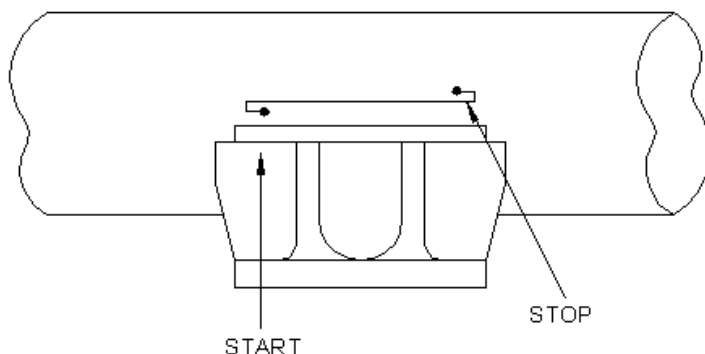

Figure 2.4.2



## INSTALLATION, MAINTENANCE & SERVICE BULLETIN

Earthing of the axle should be done on one of the parts attached to the axle such as the booster brackets, camshaft support brackets or the brake spider.

**Note:** Do not connect the earth cable to any part of the axle assembly that will put a wheel bearing between the ground cable and weld area.

The area to be welded must be clean and free of grease, dirt or other contaminants that might affect the quality of the welds. Brackets that wrap around the axle should touch the axle as shown in Figure 2.4.3, view A. With this type of fit, loads on the bracket are transferred directly to the axle. The bracket as shown in figure 2.4.3 view B would transfer the load through the weld. This may overstress and crack the weld.

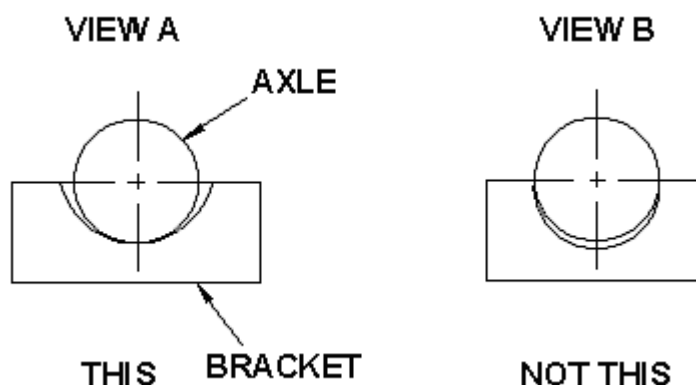

Figure 2.4.3

When a bracket is attached to an axle with U bolts and a weld, tighten the U bolts whenever possible to the specifications of the manufacturer before welding. This ensures that the loads in the bracket are not transferred in the weld. Distortion and residual stresses that happen when welding parties to the axle can be minimized by tack welding the parts to the axle before fully welding, as shown in figure 2.4.4. Be sure to thoroughly clean the slag from the tack welds before applying the final welds.

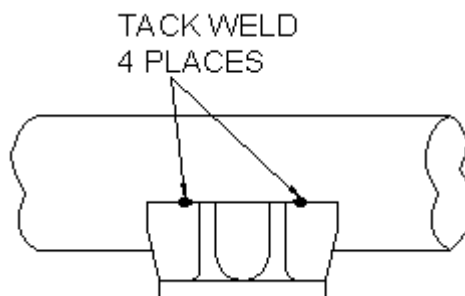

Figure 2.4.4

## INSTALLATION, MAINTENANCE & SERVICE BULLETIN

### 2.4 Torque Arm Assembly

Assemble the adjustable torque arms to the same length as the fixed torque arms. Fit the fixed torque arms on the curb side and the adjustable on the driver's side. Fit the end of the torque arm in the bracket and insert the bushes\* from each side. **Lubricate all tapered rubber and poly bushes on the taper surfaces with a liquid soap solution (50% liquid soap – 50% water) or a tyre installation compound.**

**DO NOT use Rubber grease, normal chassis grease or Detergent etc.**

Fit pin, washers and nut, ensuring that the torque arm is central in the bracket. Tighten torque arm pin lock nuts to 150-200Nm.

For better bush durability, ensure correct location of the torque arm and avoid metal to metal contact (see Photo A – example of a good installation).

It may be necessary to fit special spacers (Photo C) to prevent the TA being pulled to one side and prevent excessive build up of bush material between the TA and the bracket and under the bolt head or the nut washers. (Photo B – example of a bad installation)



Photo: A

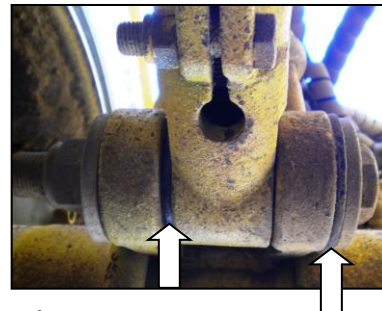

Photo: B



Photo: C

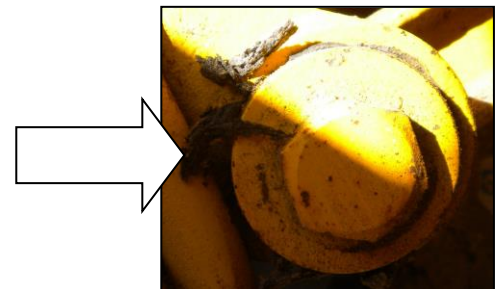

Photo: D

Ensure the bushes are installed without being damaged at installation! (Photo: D)

# INSTALLATION, MAINTENANCE & SERVICE BULLETIN

For the adjustable torque arms tighten the clamp bolts after the torque arm pin lock nuts have been fully tighten – to ensure they are not twisted and load up the bushes.

**Note:** On multi-axle suspensions, the centre and rear torque arms will be longer than those on the front axle.  
 On all underslung suspensions the adjustable torque arms must be installed with the clamp bolts to the top as shown.

\*Rubber bushes are the standard for most highway applications. Poly / urethane are optional bushes, designed for heavy duty applications (rough road, heavy duty and intensive operations). Excessive movement (up and down) of the torque arm and incorrect axle tracking (wheel alignment) will reduce the durability of the bush.

## 2.5 Drawbar Kit Assembly

Install the drawbar pin and bushes the same way as the Rocker / Equalizer assembly (see 2.9). It is recommended to insert the pin from the outside in, with the nut on the inside (as shown).

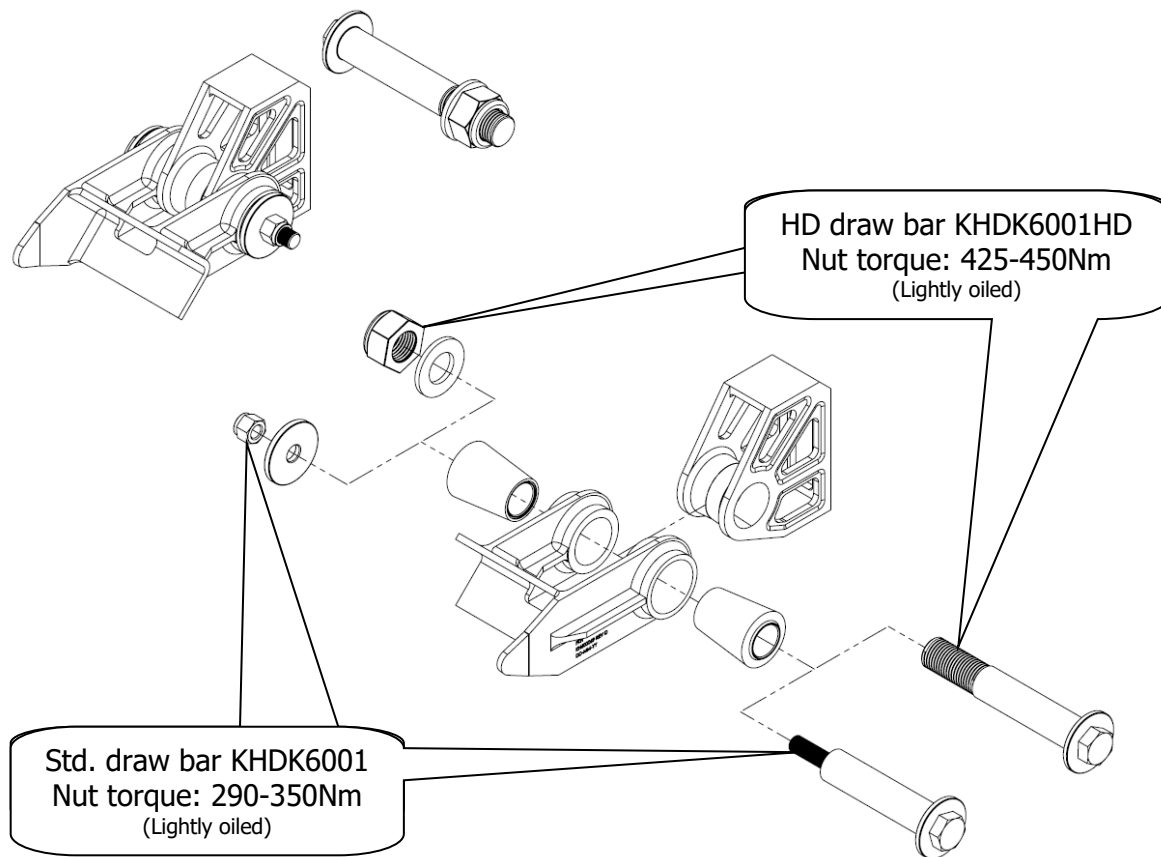

# INSTALLATION, MAINTENANCE & SERVICE BULLETIN

## 2.6 Final Assembly

Mount the springs with the hook end to the rear of the axle (with TR going to the front) on all the axles. The hook is on the opposite side of the TR.

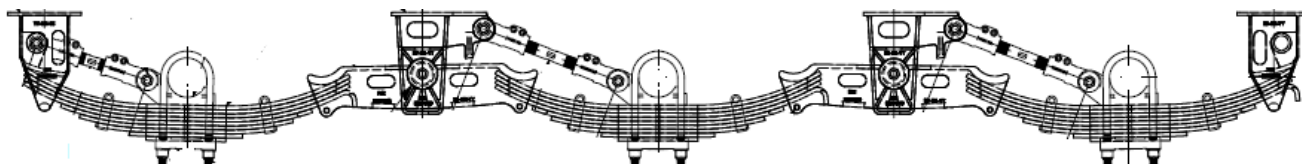

Tighten 'U' bolt nuts evenly in cross pattern as shown in figure 3.8.1.

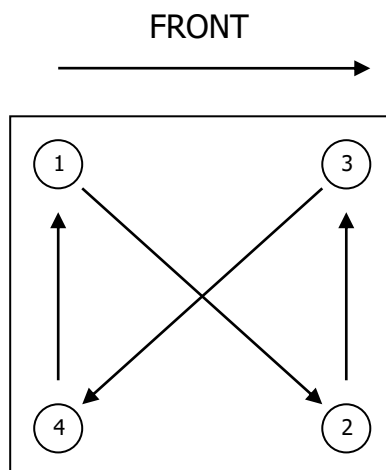

Figure 3.8.1

Fit the sub-axle assemblies in to position and connect the torque arms to the front and equalizer hangers.

Assemble the Rocker/Equalizer Bushes, centralised the rocker cover and lube the bushes.

***Lubricate all tapered rubber and poly bushes on the taper surfaces with a liquid soap solution (50% liquid soap – 50% water) or a tyre installation compound.***

***DO NOT use Rubber grease, normal chassis grease or Detergent etc.***

\*Rubber bushes are the standard for most highway applications. Poly / urethane are optional bushes, designed for heavy duty applications (rough road, heavy duty and intensive operations).

Insert spring retaining bolts into the equalizers and hangers.

# INSTALLATION, MAINTENANCE & SERVICE BULLETIN

## 3. Lube

All the lube points (grease nipples Figure 1.5.1.) must be greased, 1<sup>st</sup> after installation and again before the equipment goes in to service at PD.

Pump the lube until it purges on both sides between the rocker box and the hanger (Figure 1.5.2.).

Subsequent lubrication frequency depends on the vehicle application.



Figure 1.5.1

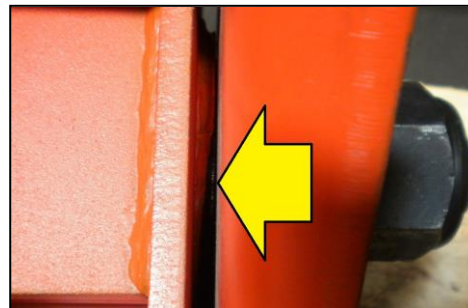

Figure 1.5.2

Check with your lube supplier for the best lube available for the application.

A normal wheel bearing grease is less than ideal. Use a Castrol Ultratak or an LE Almatek or an equivalent.

## 4. Suspension and Axle Alignment

Release the brake system and pull the trailer forward in a straight line. This will free the trailer from any binding. Ensure that the ground is level and smooth.

For best results the use of axle extensions and a kingpin post, or a suitable optical alignment device are recommended. Align the front axle by lengthening or shortening the adjustable torque arm with the king pin as shown in figure 4.1.1.

When the axles are aligned to  $\pm 3\text{mm}$  tighten the torque arm clamp nuts on the front axle.

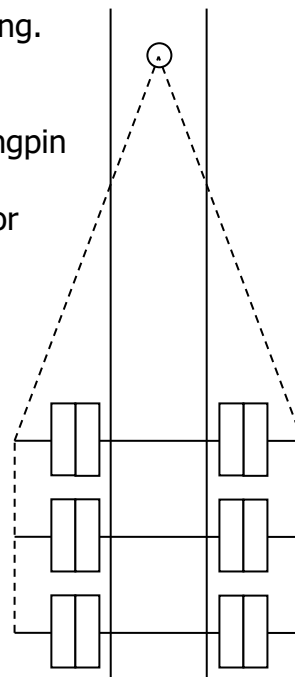

Figure 4.1.1

Align each axle with the front axle to  $\pm 1.5\text{mm}$ .

**NOTE: Left side and right side axle measurements should be equal to within  $\pm 1.5\text{mm}$ . When the axles are aligned, tighten the adjustable torque arm clamp nuts on all axles.**

After an initial loaded run-in period of approximately 1500km the alignment should be rechecked and corrected if necessary.

# INSTALLATION, MAINTENANCE & SERVICE BULLETIN

## 5. Maintenance

### 5.1 Fuwa K-Hitch Model Maintenance Schedules

The Fuwa K-Hitch leaf spring suspension, as with all suspension systems, requires regular maintenance. Periodic checks are needed to ensure continued hassle-free operation

### 5.2 Recommended Maintenance schedules

- Pre – service (PD) inspection and lube
- First service inspection, after 1500 – 4500km and lube
- Annual inspections (more frequently depending on the application)
- During replacement of any parts or assemblies
- Upon discovery of any loose components
- Regular lube where required.

### 5.3 Visual Inspection

- Loose or missing fasteners
- Cracks in hangers or axle connection brackets
- Springs centred in hangers and equalizers
- Any apparent damage or excessive wear.

If any of the above defects are noted, have the vehicle checked by a qualified mechanic.

# INSTALLATION, MAINTENANCE & SERVICE BULLETIN

## 6. Torque Chart

Torque values are specified with clean, lightly oiled fasteners, and should only be verified with a calibrated and certified torque wrench.

### 11.5t over and under slung

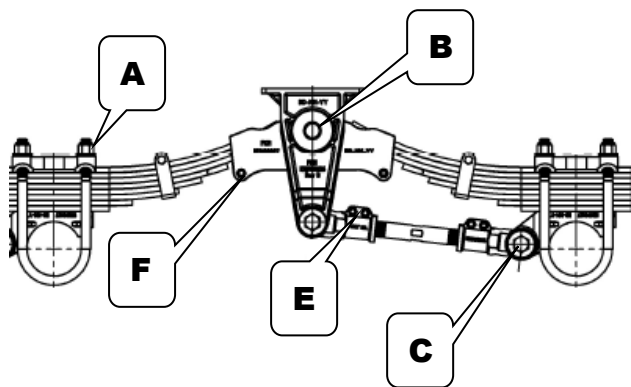

- A** U – Bolt nuts
- 11t 500-540Nm
  - 13t,16t,20t 600-650Nm
- B** Equalizer shaft fastener nuts
- 11t 290-350Nm
  - 13t, 16t, 20t 350-400Nm

- C** Torque arm bolt nuts
- 11t 150-200Nm
  - 16t, 20t 550-600Nm

### 13t over slung, 17t over slung

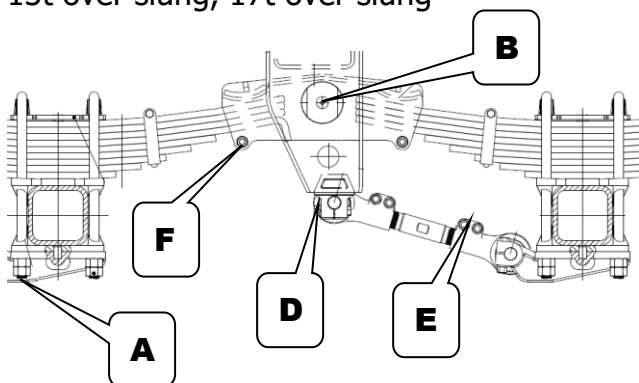

- D** Torque arm hanger clam nuts
- 13t, 16t 120-160Nm
- E** Adjust. Torque arm clamp nuts
- 11t 90-100Nm
  - 13t, 16t, 20t 120-160Nm
- F** Spring retainer bolt nuts
- 11t 75-80Nm
  - 13t,16t, 20t 110-120Nm

### 17t under slung, 20t under slung

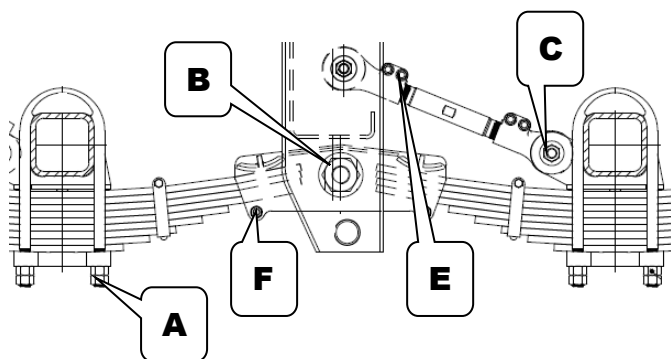

### 20t over slung

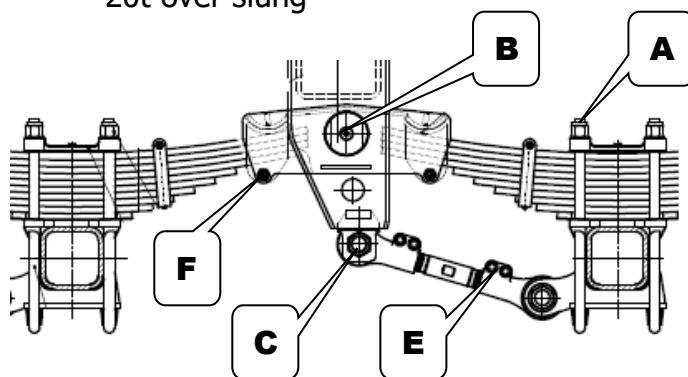



# INSTALLATION, MAINTENANCE & SERVICE BULLETIN

## 7. Trouble Shooting

### 7.1 Fasteners

Loose fasteners need immediate attention. Check components for wear and be sure that the holes have not deformed or worn in any way. When replacing any fastener, ensure that the threads are clean and undamaged and lightly oil the thread before use. Consult the maintenance section on the correct torque specifications. To ensure the correct torques, always use a calibrated, certified torque wrench.

### 7.2 Bushings

Inspect rubber bushings for large splits, tears and major wear. Rubber is degraded by sun, oils and greases. Replace any bushings that have visible damage.

See 2.4 for proper bush installation.

### 7.3 Rocker box and hangers

Check for excessive wear in the spring contact area. Replace if required.

### 7.4 Springs

Replace broken and worn springs.