



FUWA K HITCH (Australia) Pty Ltd

ABN 54 078 731 209

Head Office

Melbourne

13-21 Bliss Court
Derrimut VIC 3026
Tel. 03 9369 0000
Fax. 03 9369 0100

Queensland

41 Moreton
Heathwood Qld 4110
Tel. 07 3372 2223
Fax. 07 3372 1022

Perth

5 Freight Road
Kenwick WA 6107
Tel. 08 9350 6470
Fax. 08 9350 6570

SALES SPEC SHEET

AXLE KF21



The K Hitch series of **ONE-PIECE FORGED AXLES** are available in a variety of configuration to suit most application.

The following model information is specific to the KF21, but features like induction hardened bearing journals, premium bearings and seals and OE quality brake linings are standard to all FUWA K HITCH axles.

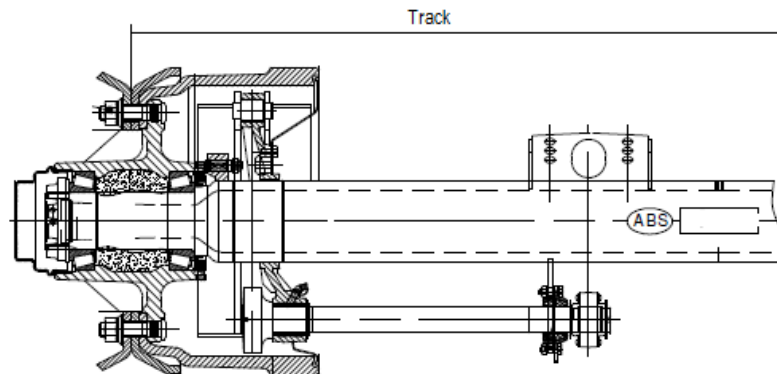

CAPACITY TON	BEARING TYPE	BRAKE TYPE	S-CAM SIZE	S-CAM TYPE	WHEEL END OPTIONS	TRACK
11.5t	TP	Ø420x180 (16.5"x7") XEM - 4515	1-5/8" - 37 Spline	ENCLOSED	•10x285 •10x335 •5 SPOKE	1850

C-C BOOSTERS	WEIGHT	ABS	AXLE BEAM SIZE	LUBE	SARN CTA
257	345KG*	Pole ring fitted Sensor mounting fitted	Ø127x18	Grease	35665 CTA-035665

Note*: Specific configuration KF21 BG 16L 1850 U30S



FUWA K HITCH (Australia) Pty Ltd

ABN 54 078 731 209

**Head Office
Melbourne**
13-21 Bliss Court
Derrimut VIC 3026
Tel. 03 9369 0000
Fax. 03 9369 0100

Queensland
41 Moreton
Heathwood Qld 4110
Tel. 07 3372 2223
Fax. 07 3372 1022

Perth
5 Freight Road
Kenwick WA 6107
Tel. 08 9350 6470
Fax. 08 9350 6570

KF21 SERVICE INFORMATION

BULLETIN NUMBER	TOPIC	DESCRIPTION
KPW-002-0110	Warranty	Limitation of Liabilities
KPW-004-0110		LGL's
KPM-001-0110		Claim Form
KPM-001-0814	Installation	List of all Bulletins which are useful and may need to be referred to when installing a FKH axle.
		Application specific engineering drawings are available upon request.
KPS-001-1012	Parts	Parts View
KPM-004-0310	Maintenance	In service maintenance

Bulletins:

All Bulletins are on: www.khitch.com.au

...or call FKH at your nearest location.

