



# FUWA K HITCH (Australia) Pty Ltd

ABN 54 078 731 209

## Head Office

### Melbourne

13-21 Bliss Court  
Derrimut VIC 3026  
Tel. 03 9369 0000  
Fax. 03 9369 0100

## Queensland

41 Moreton  
Heathwood Qld 4110  
Tel. 07 3372 2223  
Fax. 07 3372 1022

## Perth

5 Freight Road  
Kenwick WA 6107  
Tel. 08 9350 6470  
Fax. 08 9350 6570

## SALES SPEC SHEET

# AXLE KF23

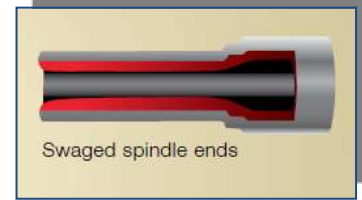

The K Hitch series of **ONE-PIECE FORGED AXLES** are available in a variety of configuration to suit most application. The following model information is specific to the KF23. The induction hardened bearing journals, premium bearings and seals are standard to all FUWA K HITCH axles. The OE quality brake callipers are supplied by WABCO.

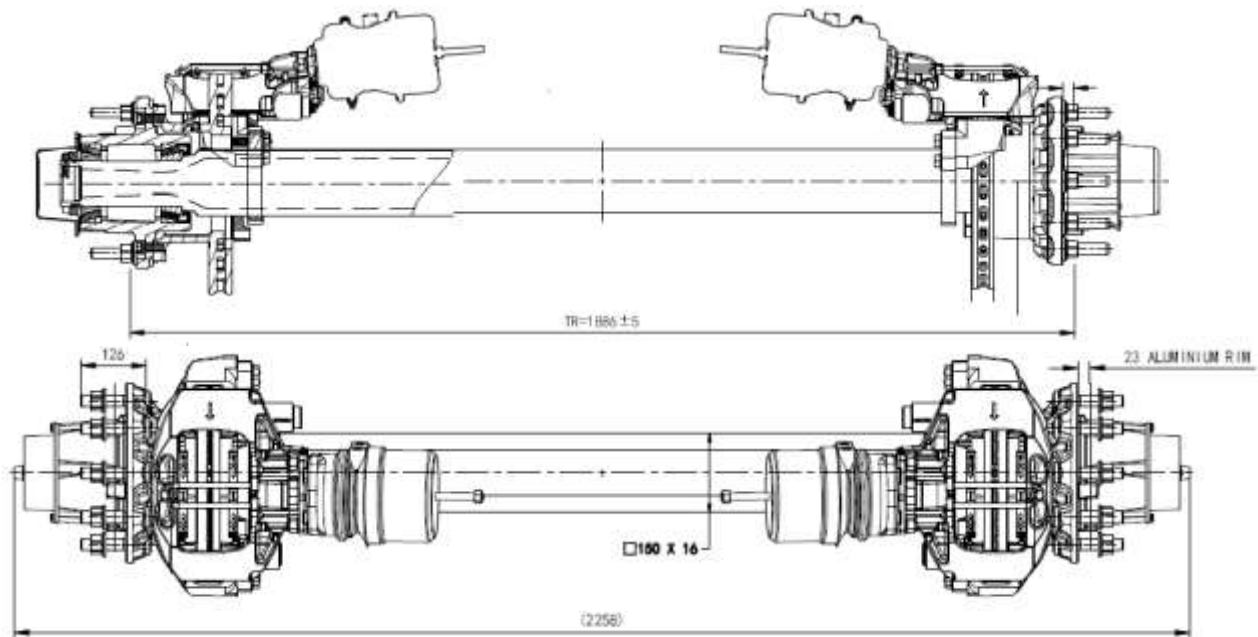

CAPACITY TON	AXLE BEAM SIZE	BRAKE TYPE	TRACK	WHEEL END OPTION BEARING TYPE	LUBE	WEIGHT	SARN CTA
13t	Ø127 x 18	WABCO PAN 22 Ø 430mm Rotor ABS pole ring & sensor mounting	1850, 1886	10 x 285	Grease	343KG*	50381 CTA-050381
12t	□150 x 150 x 15 (Air susp. only!)		(Check availability)	TP (Adjustable) ConMet (Preset)			

Note\*: KF23 BG 15L 1850 PXX



# FUWA K HITCH (Australia) Pty Ltd

ABN 54 078 731 209

## Head Office

### Melbourne

13-21 Bliss Court  
Derrimut VIC 3026  
Tel. 03 9369 0000  
Fax. 03 9369 0100

## Queensland

41 Moreton  
Heathwood Qld 4110  
Tel. 07 3372 2223  
Fax. 07 3372 1022

## Perth

5 Freight Road  
Kenwick WA 6107  
Tel. 08 9350 6470  
Fax. 08 9350 6570

## KF23 SERVICE INFORMATION

BULLETIN NUMBER	TOPIC	DESCRIPTION
KPW-002-0110	Warranty	Limitation of Liabilities
KPW-004-0110		LGL's
KPM-001-0110		Claim Form
KPM-001-0814	Installation	List of all Bulletins which are useful and may need to be referred to when installing a FKH axle. Application specific engineering drawings are available upon request.
KPS-004-0513	Parts	Parts View
KPM-004-0310 PAN22-1-Service Manual	Maintenance	In service maintenance

### Bulletins:

All Bulletins are on: [www.khitch.com.au](http://www.khitch.com.au)

...or call FKH at your nearest location.

