

PARTS VIEW

KF85 DRUM BRAKE HD AXLE (FD2482)

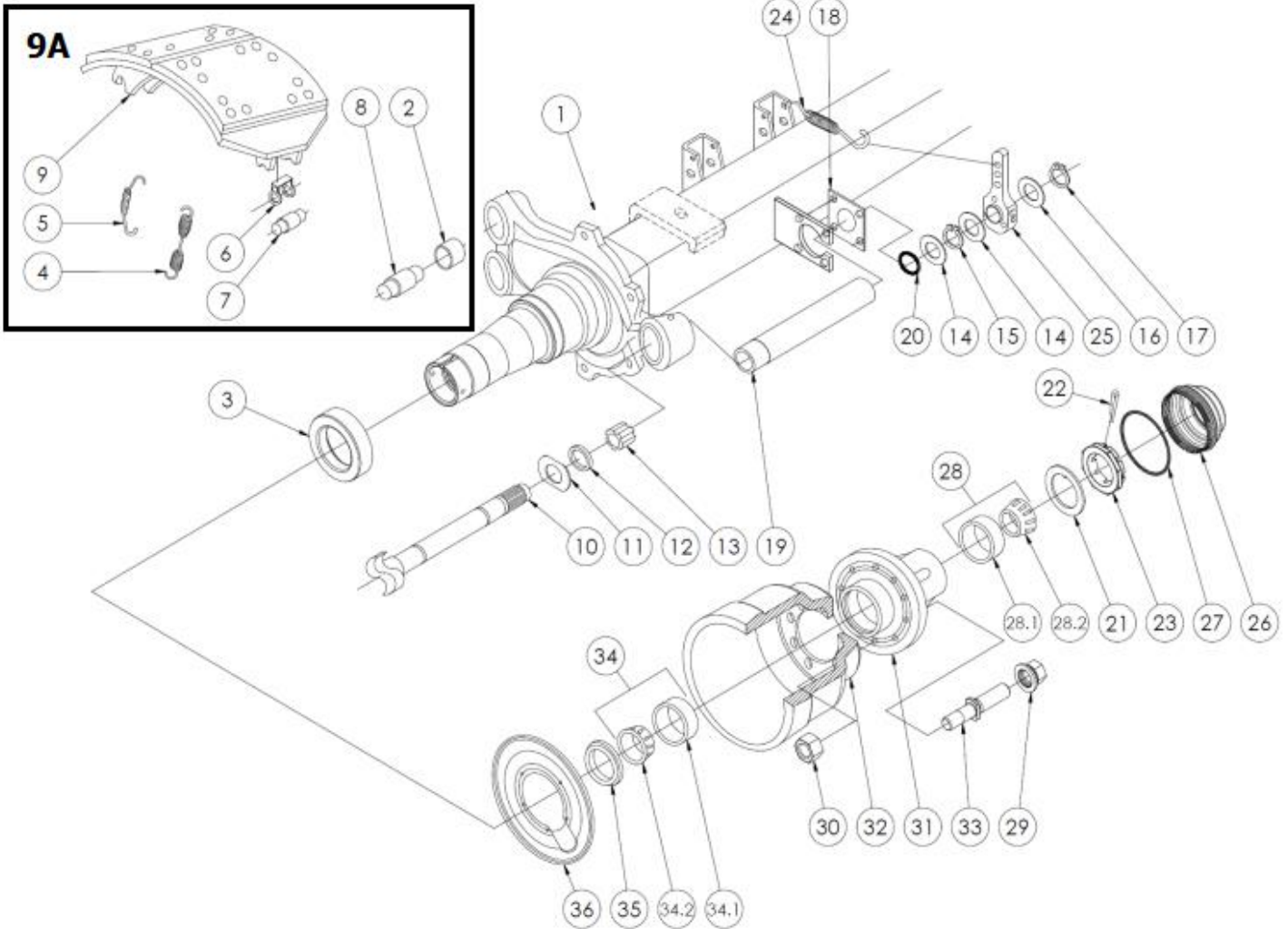

IMAGES FOR ILLUSTRATION PURPOSES ONLY

PARTS VIEW

Ref No.	PART No.	DESCRIPTION	APPLICATON	
			QUANTITY PER AXLE	KF85 FD2482XE02AA
1	FD24XE00	AXLE BEAM ***	1	X
2	NSS*	BUSH ANCHOR PIN	4	X
3	NSS*	SPINDLE SPACER	2	X
4	NSS*	HEAVY DUTY RETURN SPRING	2	X
5	NSS*	SPRING ANCHOR PIN	4	X
6	NSS*	RETAINER ROLLER	4	X
7	NSS*	ROLLER	4	X
8	NSS*	ANCHOR PIN	4	X
9	NSS*	SHOE SET (2)	2	X
9A	D20-010201K	BRAKE SHOE KIT INCLUDING HARDWARE	2	X
10	C11-0101C-543LH	S-CAMSHAFT – LH (new)	1	X
10	C11-0101C-543RH	S-CAMSHAFT – RH (new)	1	X
10	C11-0101C-613LH	S-CAMSHAFT – LH (old)	1	X
10	C11-0101C-613RH	S-CAMSHAFT – RH (old)	1	X
11	C12-0101	THRUST WASHER	2	X
12	C14-0301	SEAL	2	X
13	C13-0301	BUSH	2	X
14	C15-0101	WASHER	4	X
15	C16-0401	SNAP RING	2	X
16	C15-0102	WASHER	2	X
17	C16-0101	SNAP RING	2	X
18	C33-0101	MOUNTING PLATE S-CAM TUBE	2	X
19	C30-0102-543	S-CAM TUBE (new)	2	X
19	C30-0102-613	S-CAM TUBE (old)	2	X
20	C24-0101	O-RING	2	X
21	A11-0101	WASHER	2	X
22	A13-0101	COTTER PIN	2	X
23	A12-0101	NUT	2	X
24	A20-0101	SPRING, SLACK ADJUSTER	2	X
25	61137370EF (A19-0307)	SLACK ADJUSTER	2	X
26	KH800205B	HUB CAP	2	X
27	H15-0201	O-RING	2	X
28	H12-0100	BEARING ASSEMBLY, OUTER	2	X
29	H34-0401	NUT, WHEEL – (M24x1.5)	20	X
30	H40-0101	NUT, STUD	20	X
31	H31-8201	HUB – 10 x 335	2	X
32	H32-2304	DRUM	2	X
33	H33-2401	STUD – (M24x1.5 – 140mm)	20	X
34	H12-0500	BEARING ASSEMBLY, INNER	2	X
35	H11-0401	SEAL OIL	2	X
36	H18-0104	DUST SHIELD	2	X

Note: 34.1 & 34.2 and 28.1 & 28.2 should only be replaced as a set.
 *** Check axle beam part number for track size required.