

# VDL Weweler

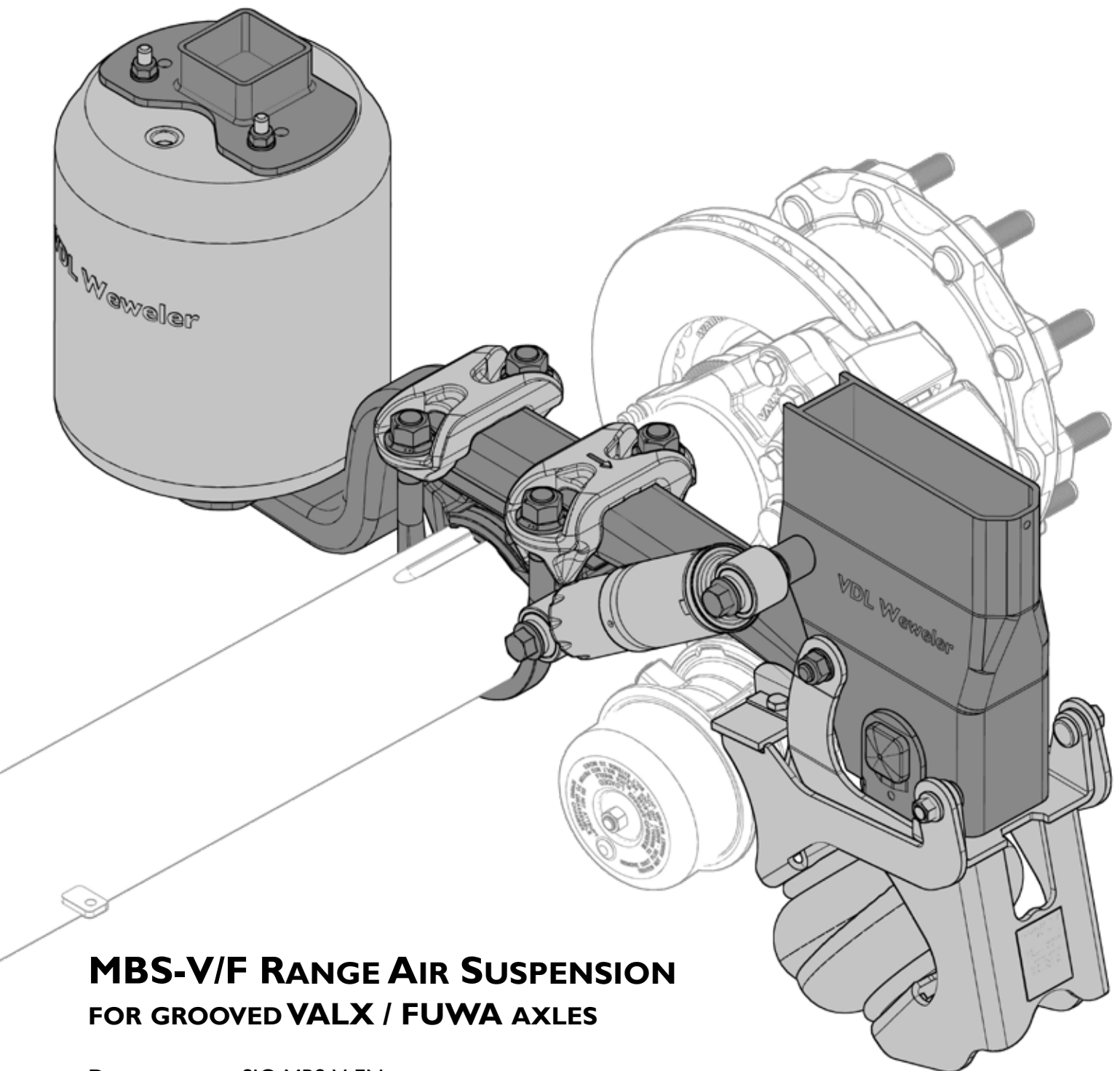

## SUSPENSION INSTALLATION GUIDE



### **MBS-V/F RANGE AIR SUSPENSION FOR GROOVED VALX / FUWA AXLES**

DOCUMENT: SIG-MBS-V-EN  
DATE: 04-2021  
REVISION: G

## Contact Details

For additional information contact VDL Weweler b.v.

P.O. Box 142, 7300 AC Apeldoorn  
Ecofactorij 10, 7325 WC Apeldoorn  
The Netherlands

### General:

Tel: +31 (0)55 538 51 00  
Fax: +31 (0)55 538 51 93  
Email: [info@vdlweweler.nl](mailto:info@vdlweweler.nl)  
Website: [www.vdlweweler.nl](http://www.vdlweweler.nl)

### Aftersales / warranty:

Tel: +31 (0)55 538 51 68  
Fax: +31 (0)55 538 51 05  
Email: [aftersales@vdlweweler.nl](mailto:aftersales@vdlweweler.nl) (warranty claim)  
[quality@vdlweweler.nl](mailto:quality@vdlweweler.nl) (0 km claim)

© 2016 VDL Weweler B.V.

## Revision summary

Date	Revision	Comment	Author
February 2016	-	Initial version.	RTS
May 2016	A	Alternative torque method added for the U-bolts (page 22).	ACS
June 2016	B	11.5 "Pull the trailing arm to the front." added; 11.9 sequence added.	ACS
June 2018	C	Orientation of air spring piston on 95mm trailing arm clarified.	RTS
March 2019	D	Load-pressure formula in 5.4 corrected. Diagrams L1=520 / L2=325 added.	RTS
September 2019	E	Ø300 Combo & Ø350 air springs added. Mounting air spring at 20mm offset on 95mm trailing arms modified. Hanger bracket from HD range added. Standard hanger bracket height 380mm added.	RTS
July 2020	F	Incorrect section referrals corrected. Separate section with air spring options added. Updated tightening instructions section 10 (tolerance on M12 connection). Updated warranty & liability referral. Updated standards. Updated axle lift and paint section.	RTS
April 2021	G	Welding instruction casted bracing improved (section 4.7).	RTS

This document and all information herein is and remains at all times the exclusive property of VDL Weweler B.V. and shall not - in whole nor in part - without the prior written consent of VDL Weweler B.V. be disclosed to any other person, published in any form of publicity or news story, copied, photographed, reproduced or stored in any retrieval system of any nature.

The information in this document has been prepared solely for the purpose of providing information about assembly, disassembly, repair and maintenance on the suspension system. It has been compiled in good faith by VDL Weweler B.V. and is provided without any express or implied warranty as to its completeness or accuracy. VDL Weweler B.V. reserves the right to make amendments to this document to reflect further developments.

The original English text in this document will be binding and shall prevail in case of any variance between the English text and a translation. As any translation may be imprecise and inaccurate in whole or in part, VDL Weweler B.V. does not accept any risk, liability and responsibility for any translation.

Any quotations, offers and agreements relating to goods to be delivered and/or services to be provided by VDL Weweler BV shall always be subjected to 'VDL Weweler General Conditions for Supplies'. Any other general terms and conditions shall apply only where expressly accepted in writing by VDL Weweler BV.

© 2016 VDL Weweler B.V. All rights reserved.

## Contents

	General notes.....	4
	Welding remarks.....	4
	Warranty and liability.....	4
	Pictograms & symbols.....	5
<b>1</b>	Explanations MBS-V/F Air suspension system coding.....	6
<b>2</b>	Axle & air suspension combinations.....	7
<b>3</b>	Technical specifications / design information.....	8
<b>4</b>	Hanger brackets & pedestals.....	9
	4.1 Dimensions of hanger brackets & pedestals.....	9
	4.2 Alignment of hanger bracket .....	10
	4.3 Welding of standard hanger bracket.....	11
	4.4 Welding of HD hanger bracket.....	12
	4.5 Welding of pedestal.....	12
	4.6 Welding of plate for hanger bracket bracing.....	13
<b>5</b>	4.7 Welding of casting for hanger bracket bracing.....	13
	Air springs.....	14
	5.1 Standard Ø300 & Ø335.....	14
	5.2 Long stroke Ø300 & Ø335.....	14
	5.3 Combo Ø300 & standard Ø350.....	15
	5.4 Load-pressure diagram Ø300 air springs - 520-380 system geometry.....	16
	5.5 Load-pressure diagram Ø335 air springs - 520-380 system geometry.....	16
	5.6 Load-pressure diagram Ø300 air springs - 520-325 system geometry.....	17
	5.7 Load-pressure diagram Ø335 air springs - 520-325 system geometry.....	17
	5.8 Load-pressure diagram Ø350 air springs - 520-315 system geometry.....	18
<b>6</b>	Shock absorber overview.....	19
<b>7</b>	Alignment of system & axle .....	20
	7.1 Alignment of air suspension versus axle.....	20
	7.2 Alignment of trailing arm eye height.....	20
	7.3 Alignment of axles.....	21
	7.4 Adjusting the hanger bracket alignment.....	21
<b>8</b>	Paint instruction.....	22
<b>9</b>	Axle lifts.....	23
	9.1 Axle lift versions.....	23
	9.2 Axle lift clearance.....	23
<b>10</b>	Torque settings MBS-V/F Air suspension.....	24
<b>11</b>	Air suspension assembly.....	25
<b>12</b>	Chassis mounting.....	29
<b>13</b>	Available air spring options.....	35

## General notes

The installation instructions in this manual are specific for the VDL Weweler MBS-V/F air suspension and not valid for other systems. The used assembly jig(s) are examples that can assist with proper installation. The illustrated chassis and cross bracings are solely drawn as examples for installation as cross bracing and component dimensions depend upon the respective vehicle type and its field of application. The data is intended as a guideline for the trailer builders vehicle design.

The design of the vehicle chassis is always the responsibility of the trailer builder.

Further desired or required data for the VDL Weweler air suspensions such as additional dimensions, permitted centre of gravity heights, etc. can be found in the additional technical documents (f.e. the standard and/or application system drawings).

## Welding remarks

The trailing arms, air bags and plastic shock absorber covers are to be protected against welding sparks and weld spatter when carrying out all welding work. The earth clamp must never be connected to the trailing arm or the axle hub.

No welding is allowed on the trailing arms!

## Warranty and liability

VDL Weweler B.V. warrants all in house manufactured products and all non VDL Weweler components needed to complete a VDL Weweler product, for a period as per listed in the “Warranty tables” in the “VDL Weweler General Defects Liability Statement Trailer” or otherwise agreed in writing.

The “VDL Weweler General Defects Liability Statement Trailer” can be downloaded from our website [www.vdlweweler.nl](http://www.vdlweweler.nl).

## Pictograms & symbols

In this manual the following pictograms and symbols are used to illustrate specific instructions or warnings:

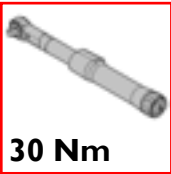

Use an appropriate calibrated torque wrench.  
Tighten the fastener to the torque in Nm given in the left-hand corner.



Use an appropriate calibrated torque wrench.  
Tighten the fastener to the torque in Nm + the additional specified turn of the fastener in degrees given in the left-hand corner .



Use a socket wrench.  
The value in the left-hand corner is the socket wrench size.



Use a hex socket wrench.  
The value in the left-hand corner is the hex socket wrench size.



Use a rubber or plastic hammer.



**CAUTION**  
Weight exceeds 25 kg.

# I - Explanation MBS-V/F Air Suspension system coding

The MBS-V/F air suspension code refers to the individual available system drawings. The code can be found in the table on the drawing.

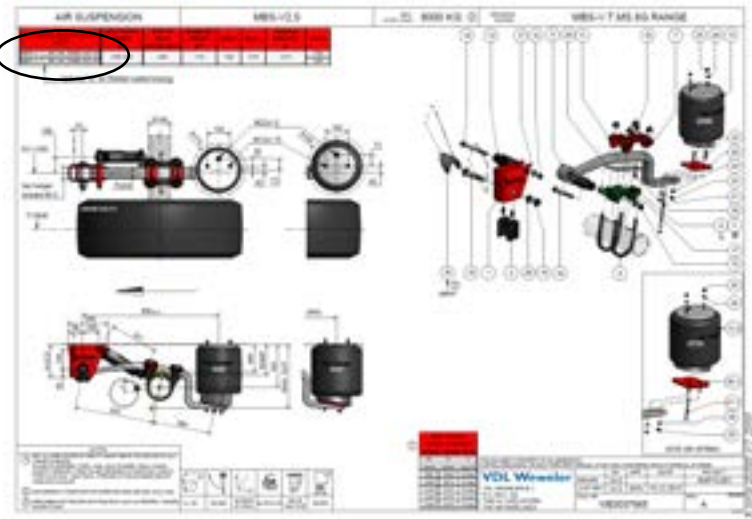

**MBS-V . T . MS . 8G . 30MB . 280 . 20**

**Air spring offset**

**Nominal ride height** (minimum ride height with lifted axle)

<b>Air spring</b>	
30K = Ø300	36 = Ø350
33K = Ø335	36R = Ø350 (reinforced piston)
30MB = Ø300 long stroke	36L = Ø350 long stroke
33MB = Ø335 long stroke	36LR = Ø350 long stroke
30C = Ø300 Combo	(reinforced piston)

**Axle clamping**  
8G = Ø146 with groove

**Trailing arm**  
M - Serie = 75mm wide trailing arm  
P - Serie = 95mm wide trailing arm

<b>Hanger bracket</b>	
Type: T (plate bracing)	Type: TW / CW (casted bracing)
Type TW / CW is prescribed for trailers with rigid body (such as reefers, tankers, moving floor)	

## 2. Axle & air suspension combinations

The VDL Weweler MBS-V/F air suspension is specifically designed for the VALX / FUWA groove axle range. Therefore it is only suitable for the VALX / FUWA disc and drum brake axles equipped with the patented groove.

For specific (technical) information concerning the axle we refer to the VALX / FUWA documentation and instructions.

### Disc brake axle (ET 120)

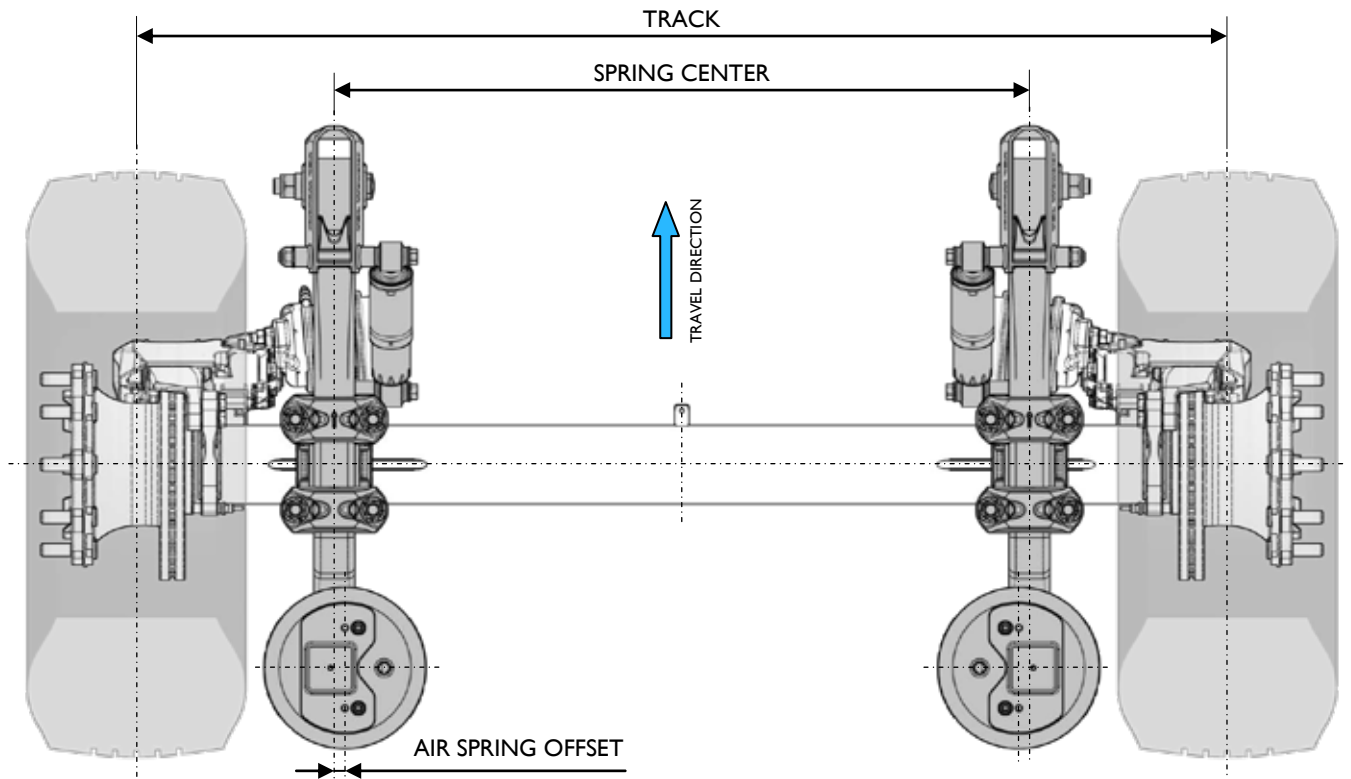

### Drum brake axle (ET 0)

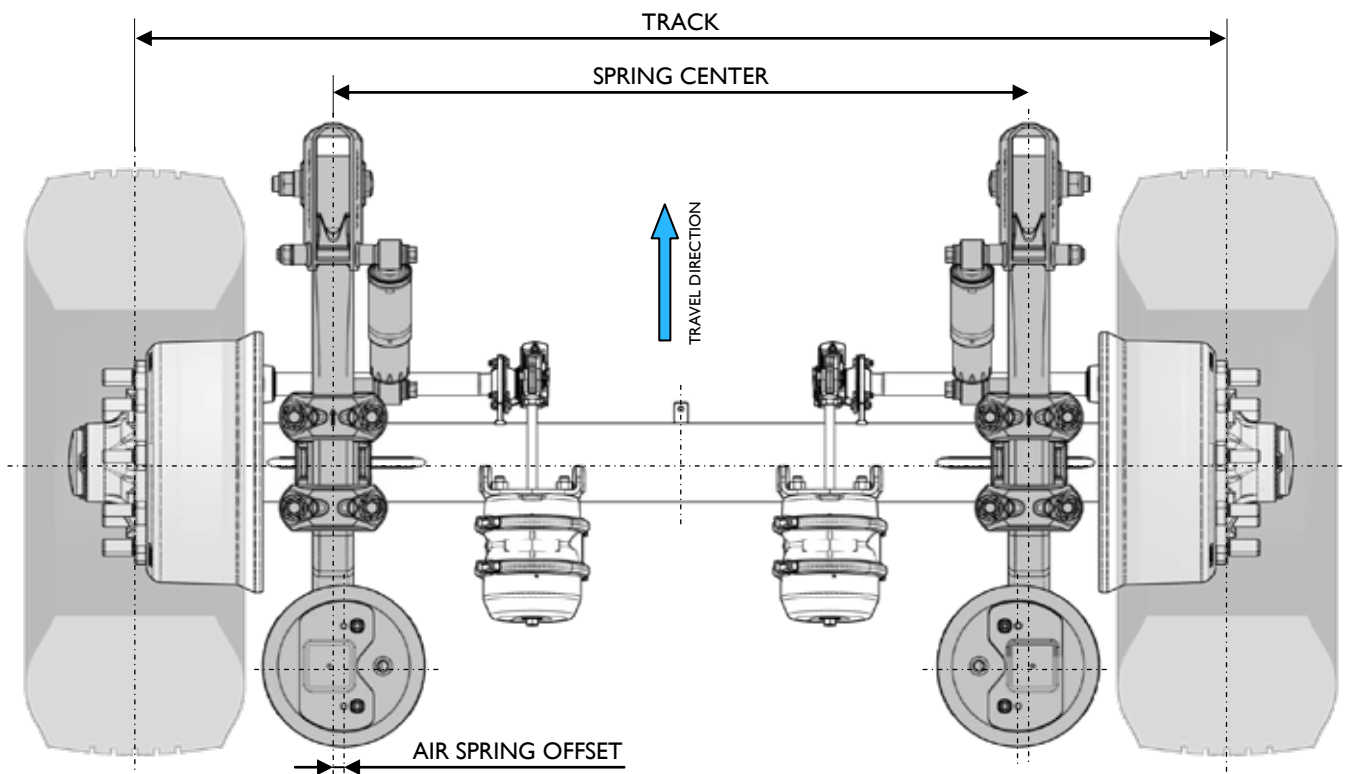

### 3. Technical specifications / design information

MBS-V/F air suspension system layout and overall system dimensions.

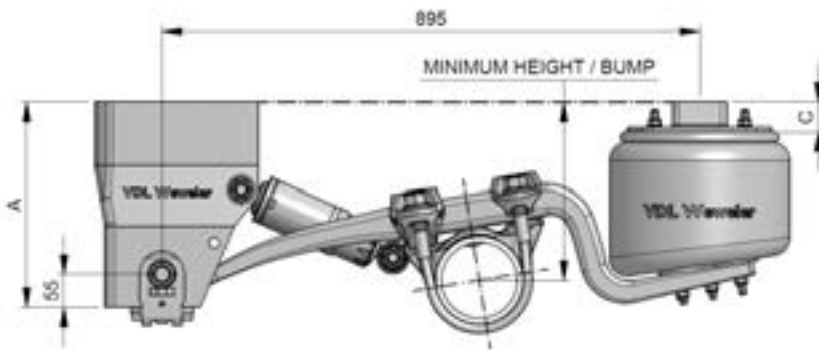

#### Minimum height & Bump:

Internal bump stops inside the air spring are used to limit the upward suspension stroke.

#### Bump

When the vehicle is empty without air the system rests on the bumpstop. This gives the system “Bump” dimension. The dimension bump also determines the lift height.

#### Minimum height (MH)

When the vehicle is fully laden without air the bump is compressed by a certain distance depending on the type of air spring.

This gives the system “Minimum Height” dimension (MH).

When an air spring failure occurs the internal bump stops enables the user to run (without air pressure) at very low speed for a short period of time to get to the nearest service station. To prevent further damage, always make sure that there is enough clearance for all moving parts.

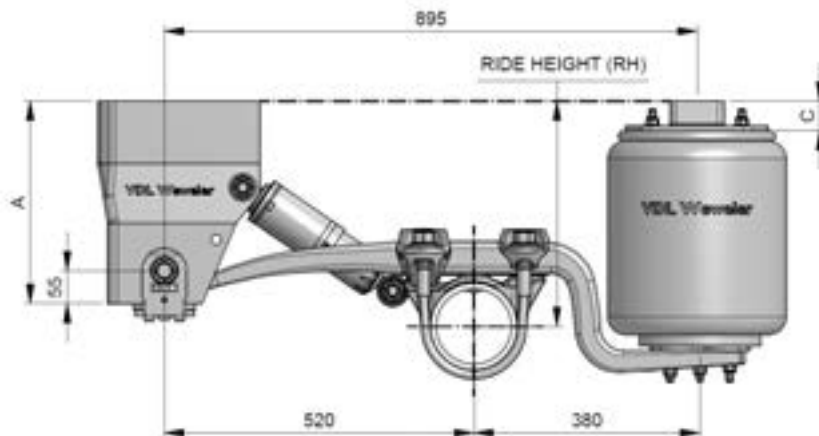

#### Ride height (RH):

The ride height can be set with the levelling valve within a certain range. Check the specific system drawing for the possible settings.

Indicated L2 dimension (f.e. 380mm) and total length depends on the system configuration.

If the vehicle is equipped with a raise/lower valve it is only allowed to use this valve for loading and unloading. Driving with the valve engaged may cause damage to the load, trailer, brakes and suspension system.

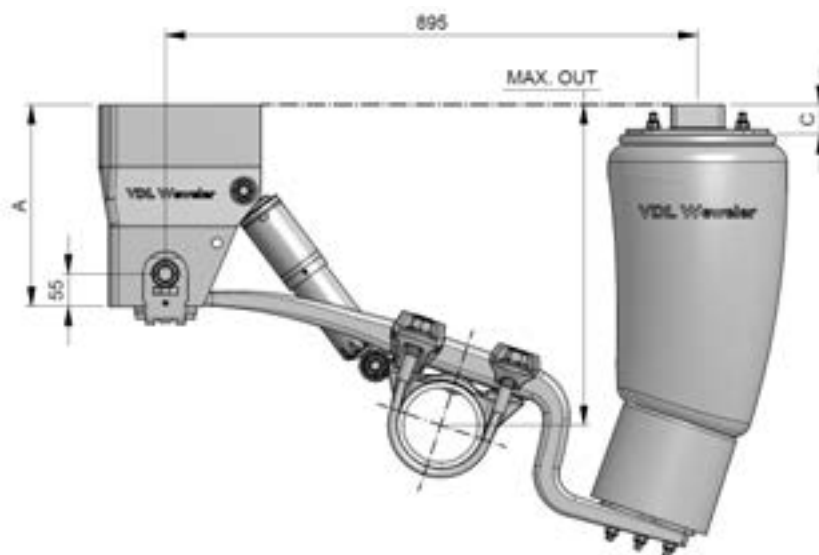

#### Max. out:

The VDL Weweler air suspension systems have been engineered so that the shock absorber acts as the outbound stroke limitation.

This obviates the need for check straps or other suspension stops.

The maximum shock absorber length and the air spring height at this maximum outward position are in relation to each other. Therefore the system configuration (hanger bracket height “A” and pedestal “C”) may not be changed without the approval of VDL Weweler.



## 4. Hanger brackets & pedestals

### 4.1 Dimensions of hanger brackets & pedestals

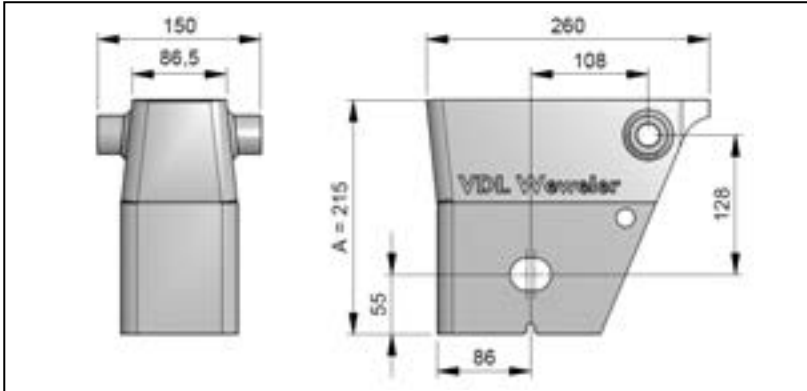

#### Hanger bracket height A = 215 mm

Standard hanger bracket available in height: 215 mm.

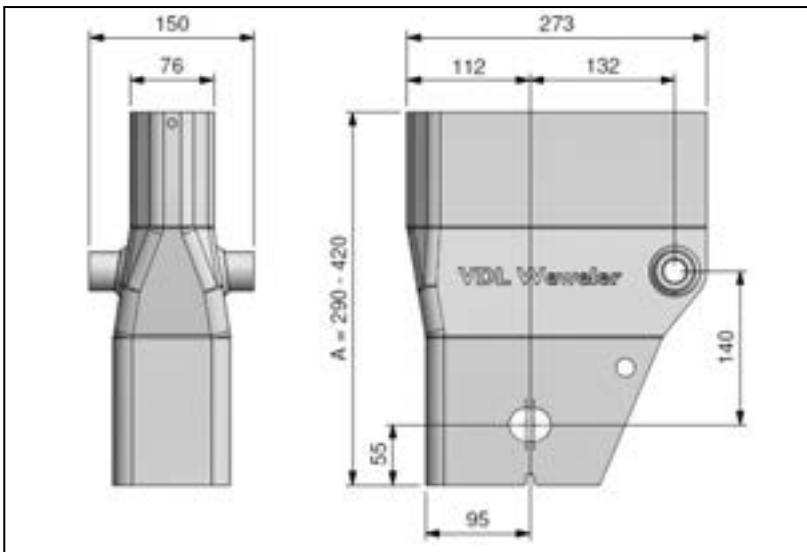

#### Hanger bracket height A = 290-420 mm

Standard hanger bracket available in heights: 290, 340, 380 and 420 mm.

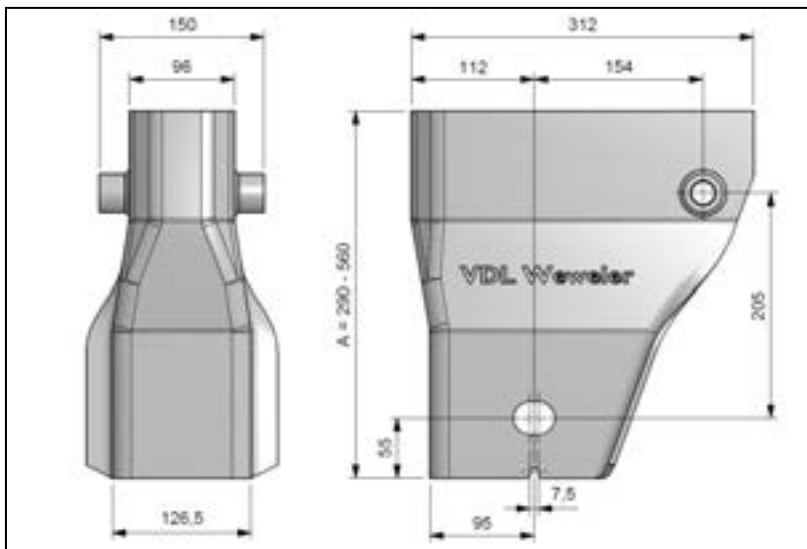

#### HD Hanger bracket height A = 290-460 mm

HD hanger bracket available in heights: 290, 310, 335, 360, 390, 410, 435 and 460 mm.

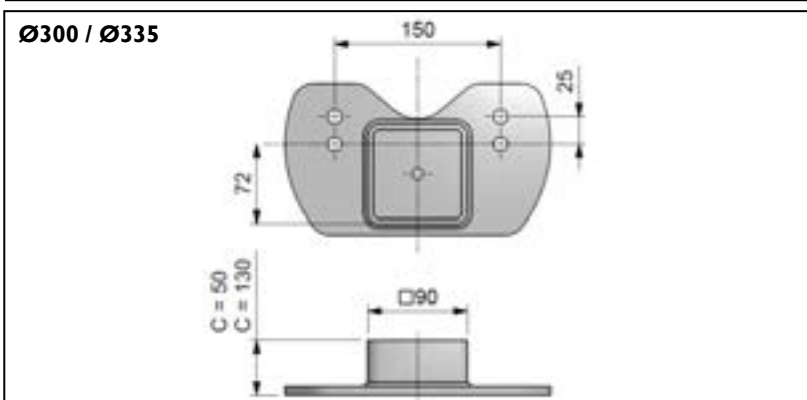

#### Pedestal for Ø300 & Ø335 air springs

Standard pedestal available in heights 50 and 130 mm.

#### 4. Hanger brackets & pedestals

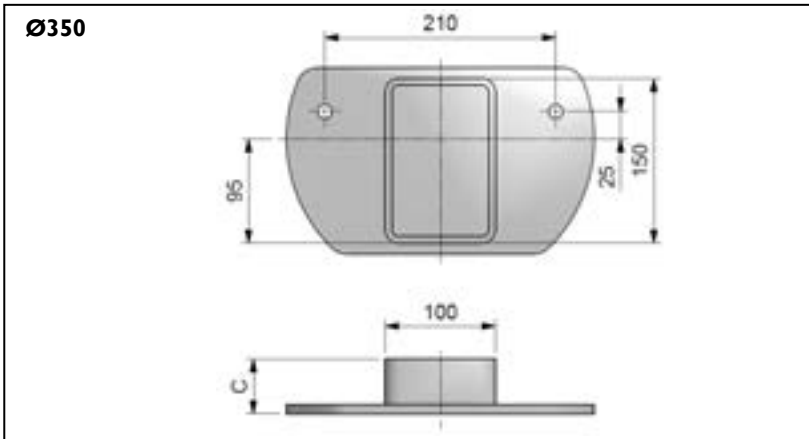

**Pedestal for Ø350 air springs**  
**C = 30-225mm**

Standard pedestal available in heights 30 up till 225 mm.

#### 4.2 Alignment of hanger bracket

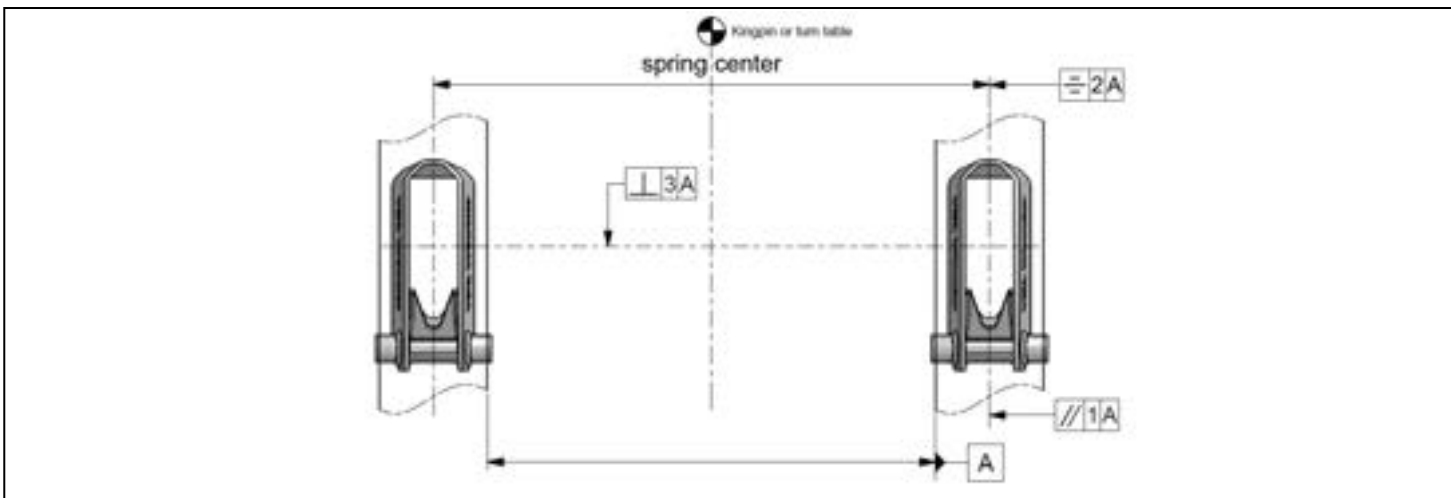

## 4. Hanger brackets & pedestals

### 4.3 Welding of standard hanger bracket

A = 215

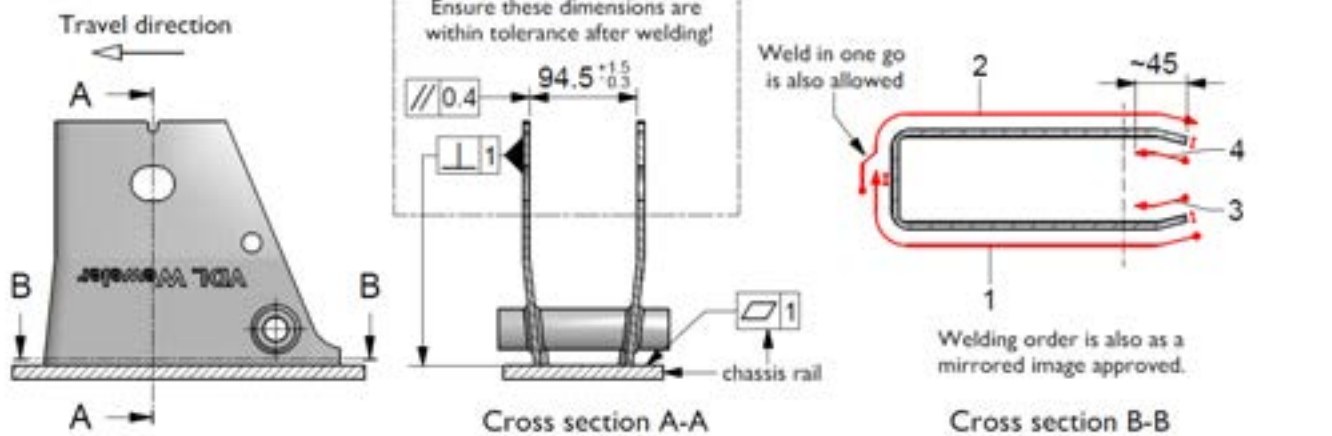

A = 290 - 420

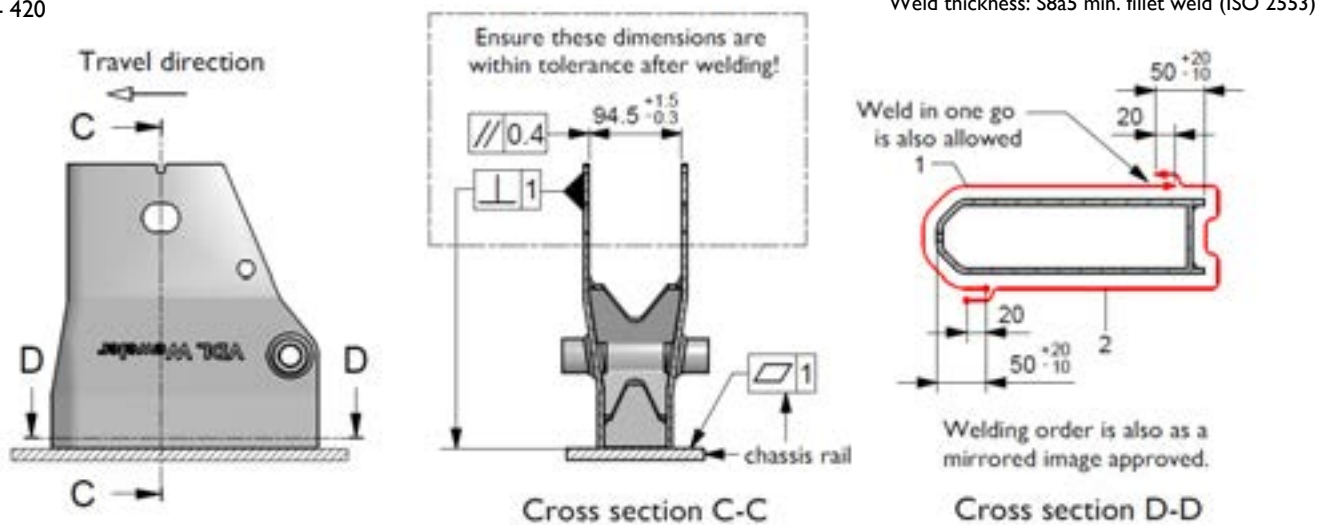

**Welding order:**

→ Tack weld ● Begin → End

Material chassis = CEV ≤ 0.47%

$$CEV = C + (Mn/6) + ((Cr+Mo+V)/5) + ((Ni+Cu)/15)$$

Item	Specifications
Welding wire	Acc. DIN EN ISO 14341. Material-Nr 1.5125, Ø1.2 mm
Supply	I-wire technique
Gas mixture	92-8 Argon / O <sub>2</sub> or Sagox2 84-13-3 Argon / CO <sub>2</sub> / O <sub>2</sub> or Sagox10 90-10 Argon / CO <sub>2</sub>
Welding parameters	Current: 240 - 340 A Puls voltage: 26 - 40 V

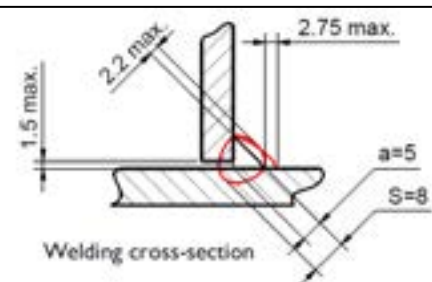

Check up:

1. Demands and qualification according DIN EN ISO 15614-1.

2. Judgement of craters according DIN EN ISO 5817 acc. class C.

Except for the numbers: 2011, 2012, 2016, 2017, 5012, 5213. Those should be judged according DIN EN ISO 5817 acc. **class B**.

## 4. Hanger brackets & pedestals

### 4.4 Welding of HD hanger bracket

Weld thickness: S8a5 min. fillet weld (ISO 2553)

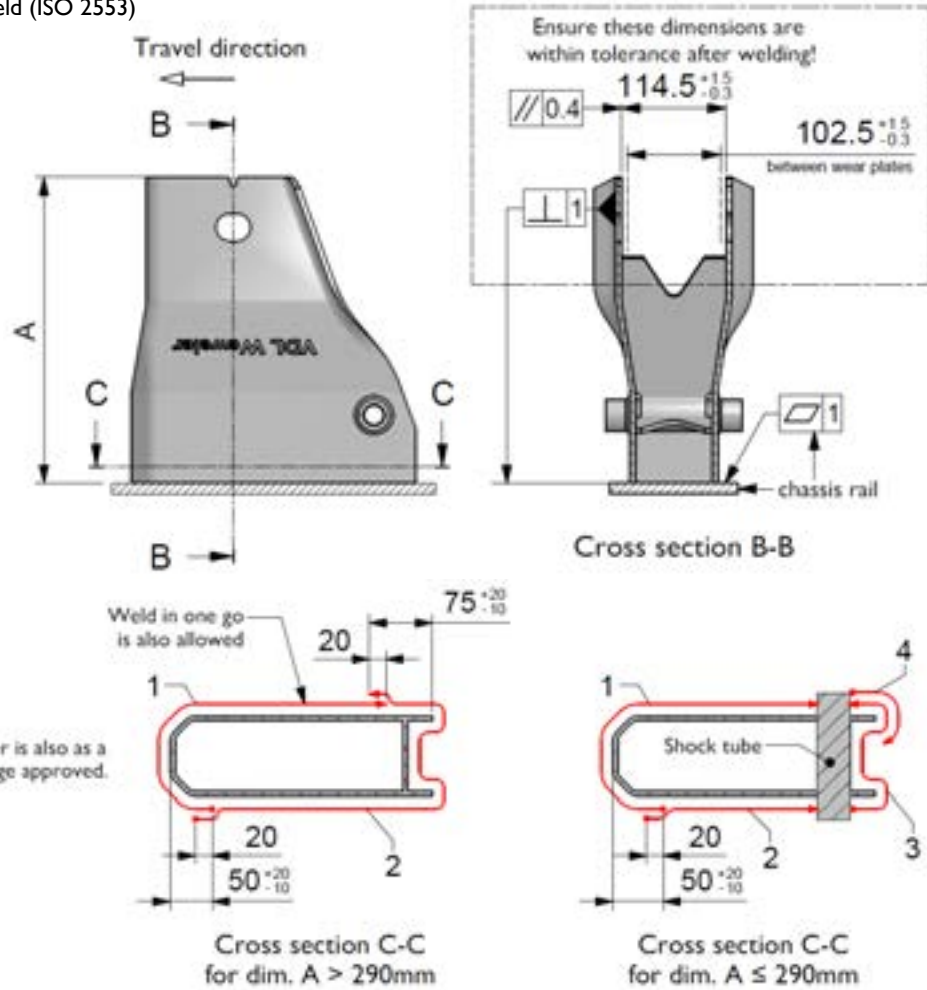

**Welding order:**

Material chassis = CEV ≤ 0.47%

CEV = C + (Mn/6) + ((Cr+Mo+V)/5) + ((Ni+Cu)/15)

Item	Specifications
Welding wire	Acc. DIN EN ISO 14341. Material-Nr 1.5125, Ø1.2 mm
Supply	I-wire technique
Gas mixture	92-8 Argon / O <sub>2</sub> or Sagox2 84-13-3 Argon / CO <sub>2</sub> / O <sub>2</sub> or Sagox10 90-10 Argon / CO <sub>2</sub>
Welding parameters	Current: 240 - 340 A Puls voltage: 26 - 40 V

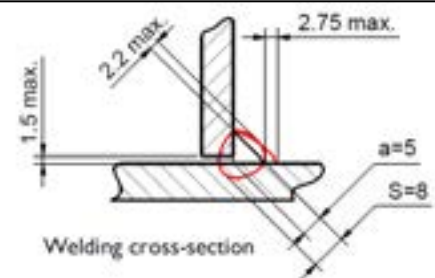

- Check up:
1. Demands and qualification according DIN EN ISO 15614-1.
  2. Judgement of craters according DIN EN ISO 5817 acc. class C.

Except for the numbers: 2011, 2012, 2016, 2017, 5012, 5213. Those should be judged according DIN EN ISO 5817 acc. **class B**.

### 4.5 Welding of pedestal

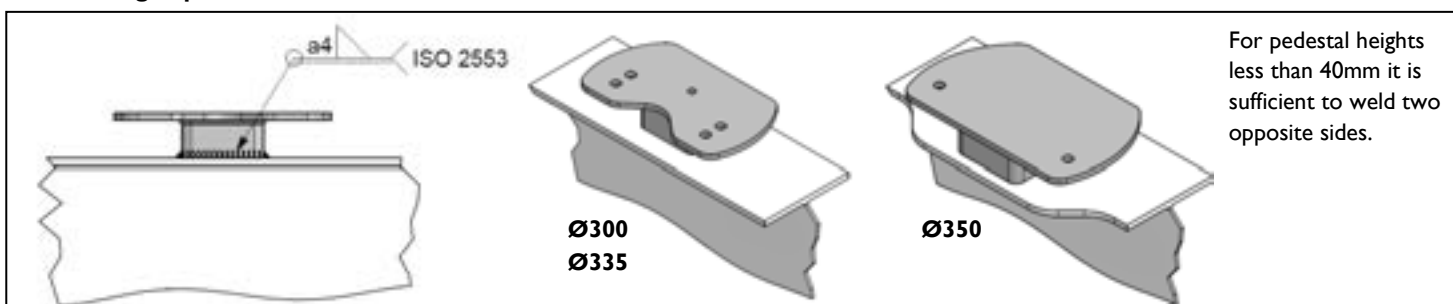

## 4. Hanger brackets & pedestals

### 4.6 Welding of plate for hanger bracket bracing

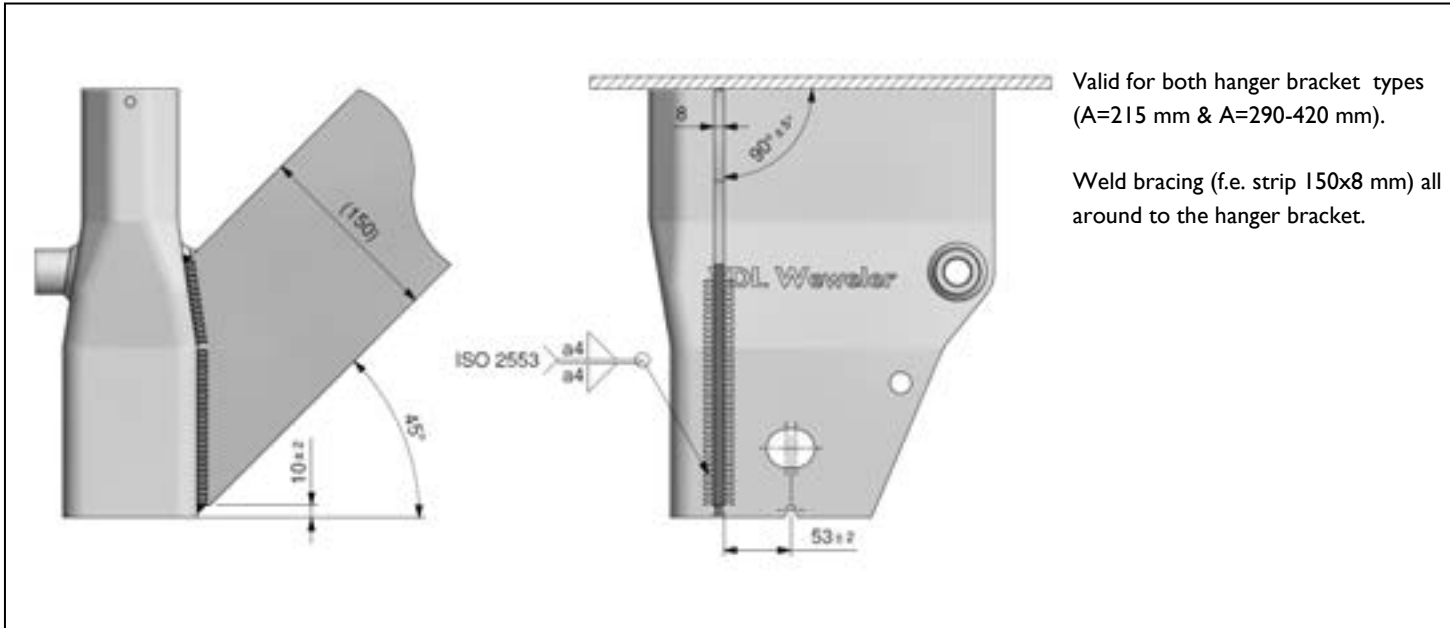

### 4.7 Welding of casting for hanger bracket bracing

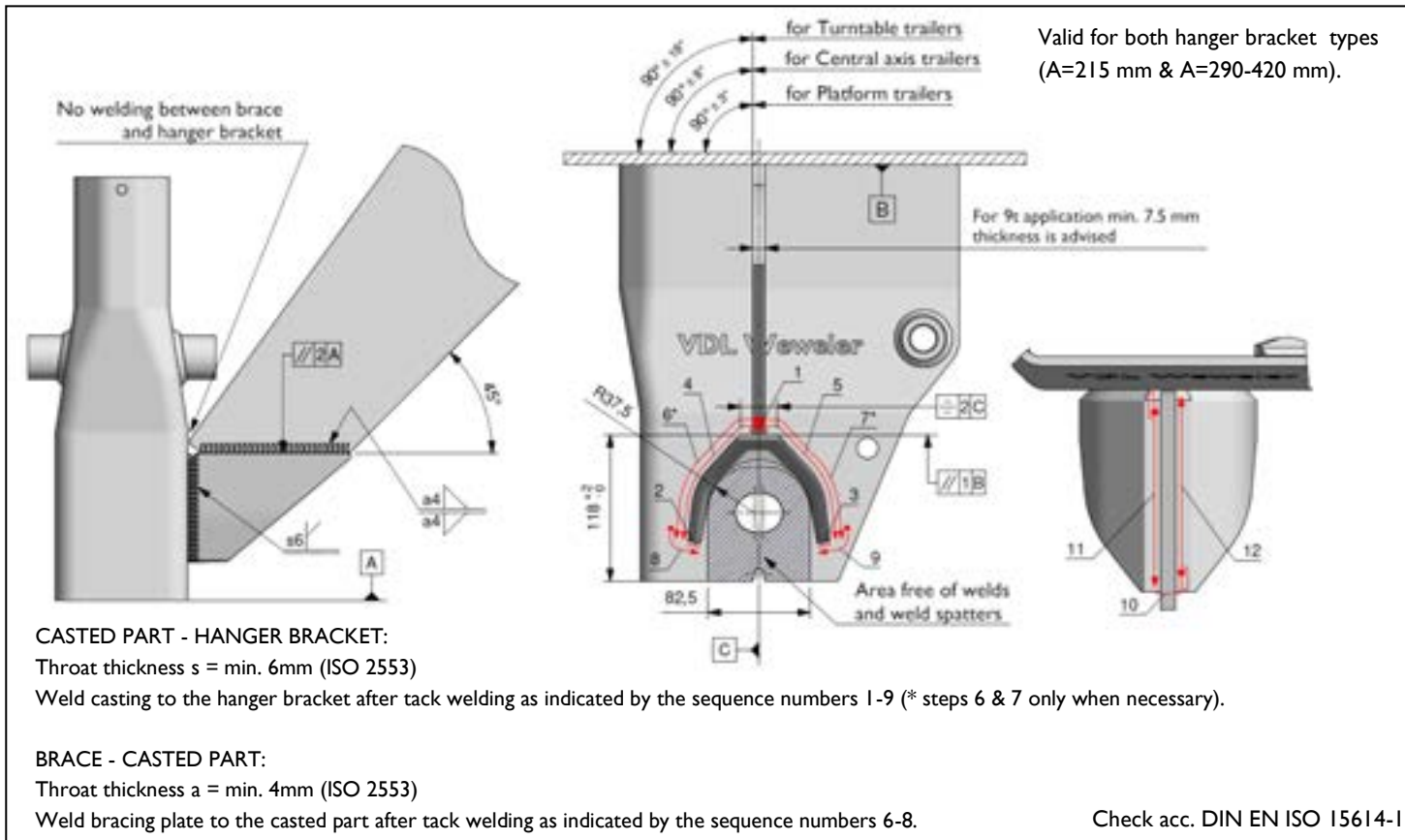

#### Welding order:

→ Tack weld ● Begin → End

Material brace = CEV ≤ 0.47%

CEV = C + (Mn/6) + ((Cr+Mo+V)/5) + ((Ni+Cu)/15)

Item	Specifications
Welding wire	Acc. DIN EN ISO 14341. Material-Nr 1.5125, Ø1.2 mm
Supply	I-wire technique
Gas mixture	92-8 Argon / O <sub>2</sub> or 84-13-3 Argon / CO <sub>2</sub> / O <sub>2</sub> or 90-10 Argon / CO <sub>2</sub>
Welding parameters	Current: 240 - 340 A Puls voltage: 26 - 40 V

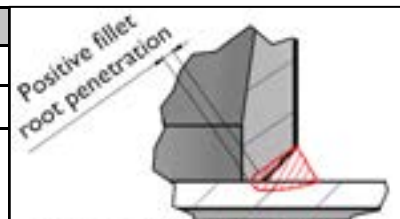

- Ensure good penetration but avoid undercutting at the edges of the weld.  
- Tack welds or craters should be fully filled.

## 5. Air springs

### 5.1 Standard Ø300 & Ø335

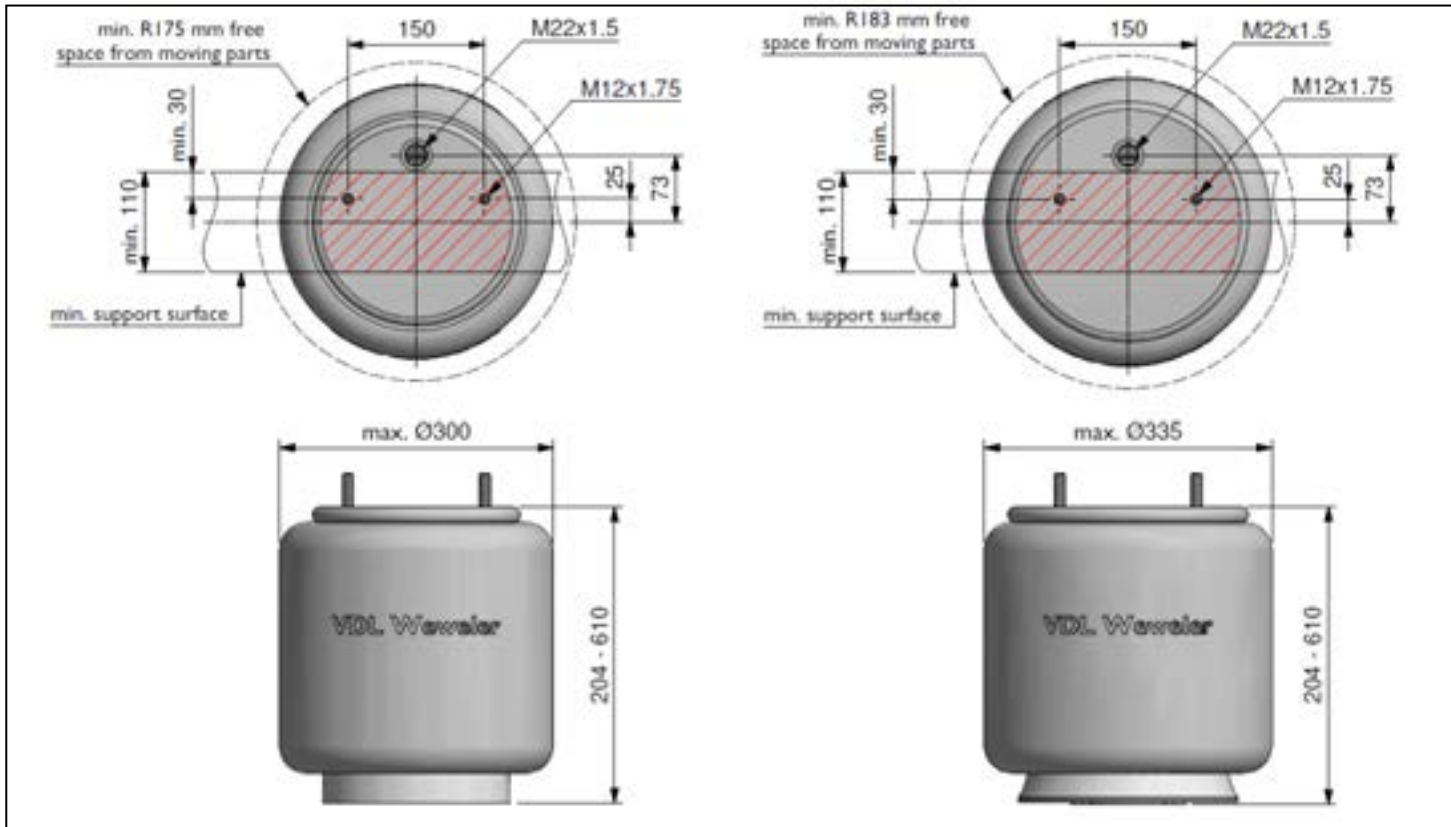

### 5.2 Long stroke Ø300 & Ø335

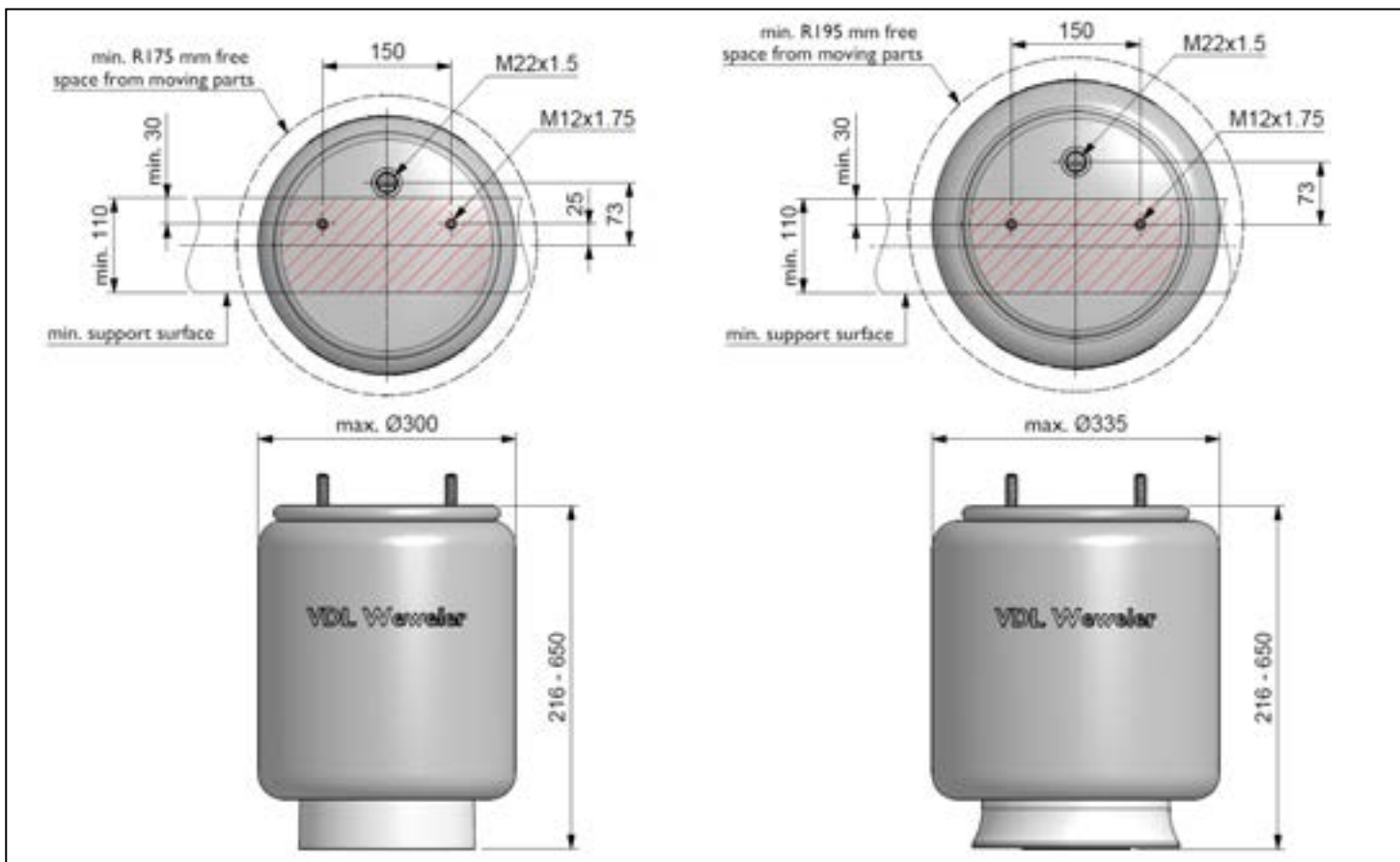

If the minimum support surface is less than 110mm an additional support plate has to be added.

## 5. Air springs

### 5.3 Combo Ø300 & standard Ø350

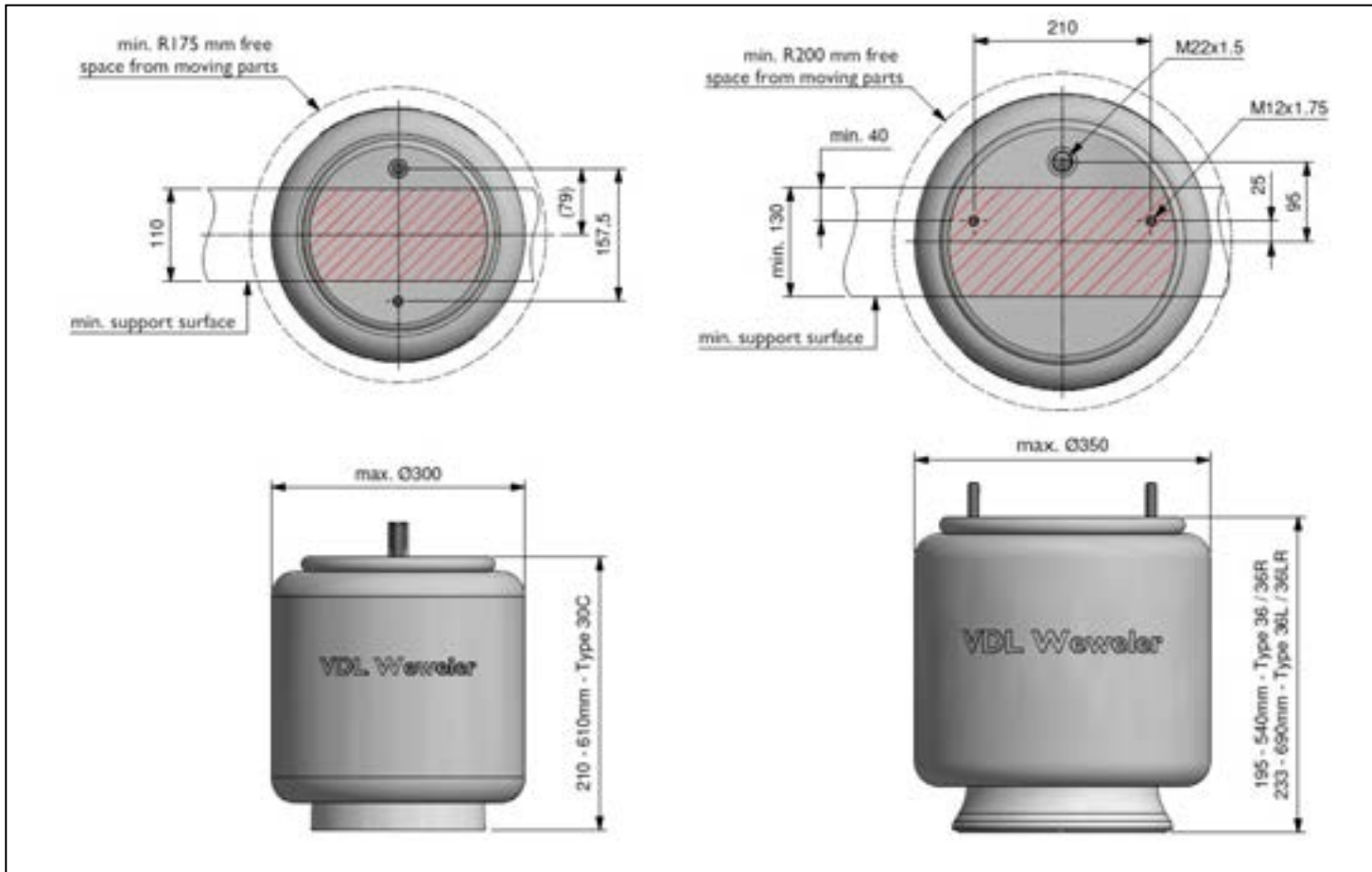

If the minimum support surface is less than indicated an additional support plate has to be added.

## 5. Air springs

### 5.4 Load-pressure diagram Ø300 air springs - 520-380 system geometry

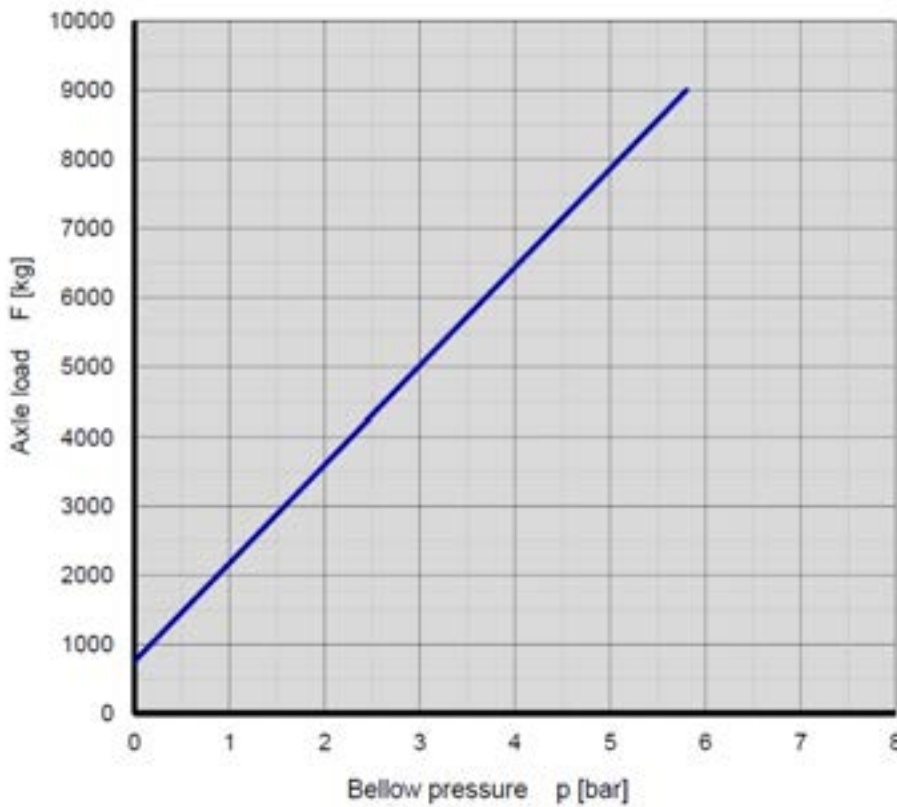

Assumed unsprung mass: 750 kg  
 Maximum axle load: 9 t  
 Reference numbers: US04100B.  
 US04200B.  
 US07074.

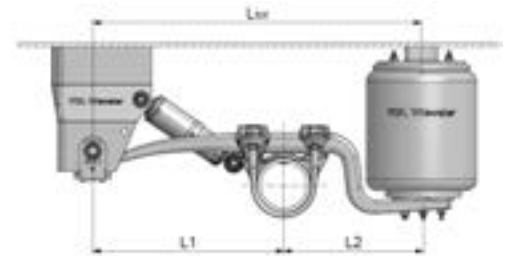

$$p = \frac{\text{axle load} - \text{unsprung mass}}{\text{geometry and air spring factor}} = \frac{F - 750}{1421}$$

Ltot = 900mm  
 L1 = 520 ± 10 mm  
 L2 = 380 ± 10 mm

This diagram is theoretical.  
 No rights can be claimed.

### 5.5 Load-pressure diagram Ø335 air springs - 520-380 system geometry

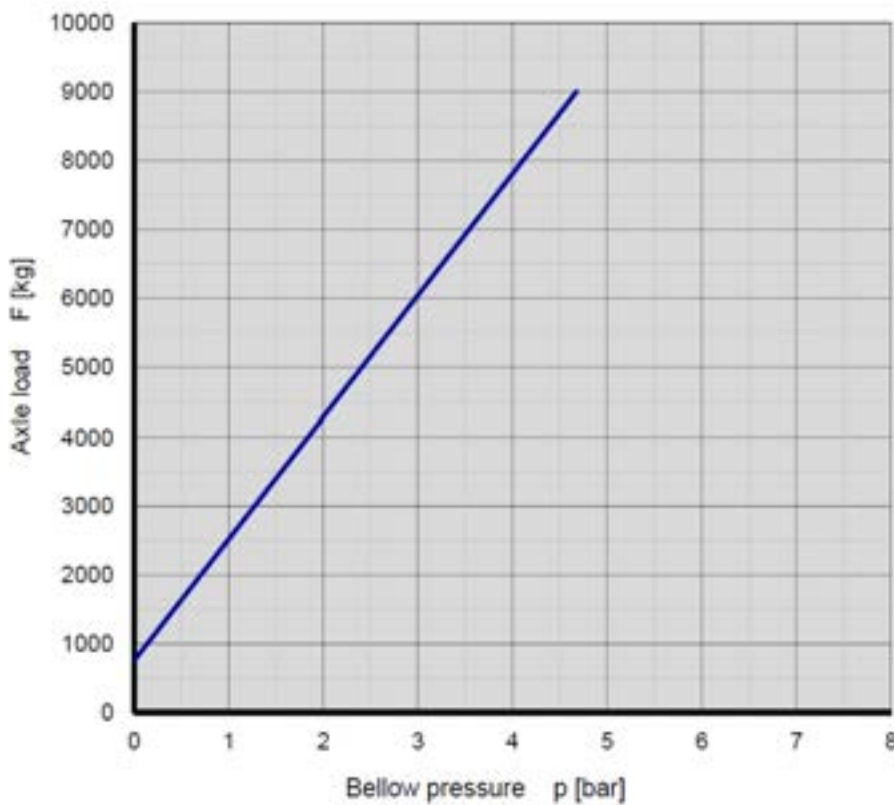

Assumed unsprung mass: 750 kg  
 Maximum axle load: 9 t  
 Reference numbers: US04110B.  
 US04235B.

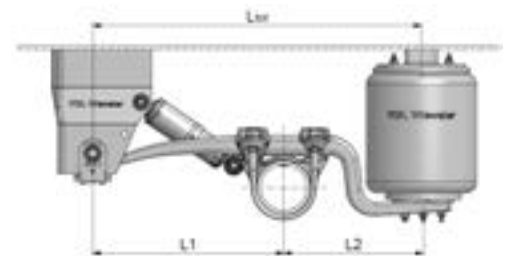

$$p = \frac{\text{axle load} - \text{unsprung mass}}{\text{geometry and air spring factor}} = \frac{F - 750}{1764}$$

Ltot = 900mm  
 L1 = 520 ± 10 mm  
 L2 = 380 ± 10 mm

This diagram is theoretical.  
 No rights can be claimed.



## 5. Air springs

### 5.6 Load-pressure diagram Ø300 air springs - 520-325 system geometry

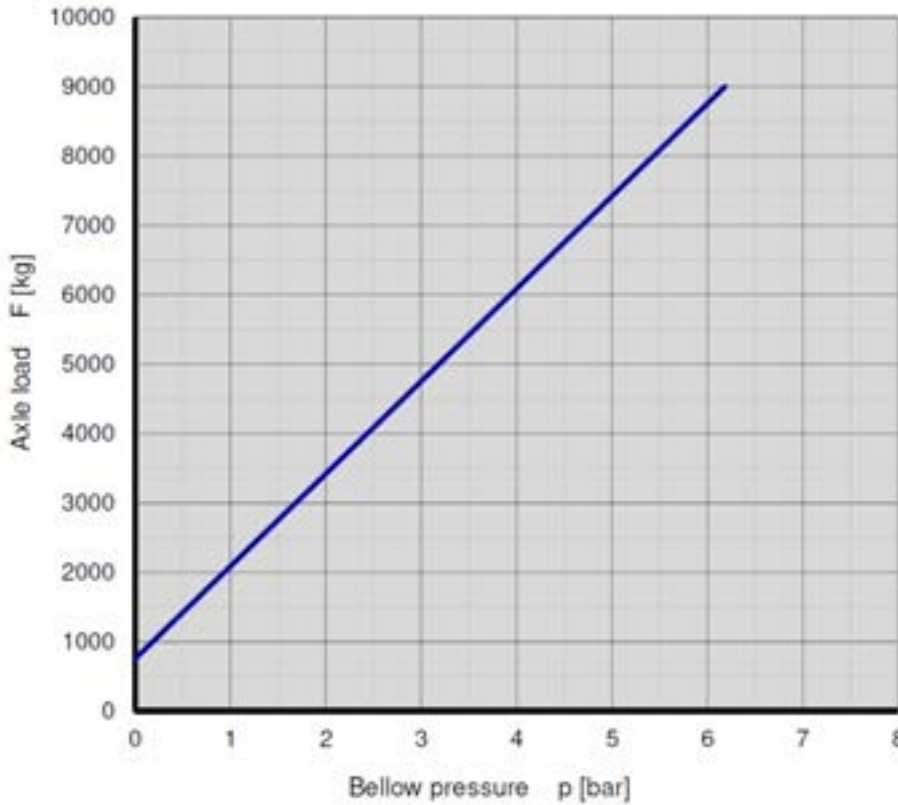

Assumed unsprung mass: 750 kg  
 Maximum axle load: 9 t  
 Reference numbers: US04100B.  
 US04200B.  
 US07074.

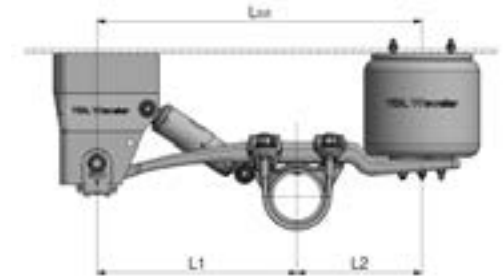

$$p = \frac{\text{axle load} - \text{unsprung mass}}{\text{geometry and air spring factor}} = \frac{F - 750}{1335}$$

Ltot = 845mm  
 L1 = 520 ± 10 mm  
 L2 = 325 ± 10 mm

This diagram is theoretical.  
 No rights can be claimed.

### 5.7 Load-pressure diagram Ø335 air springs - 520-325 system geometry

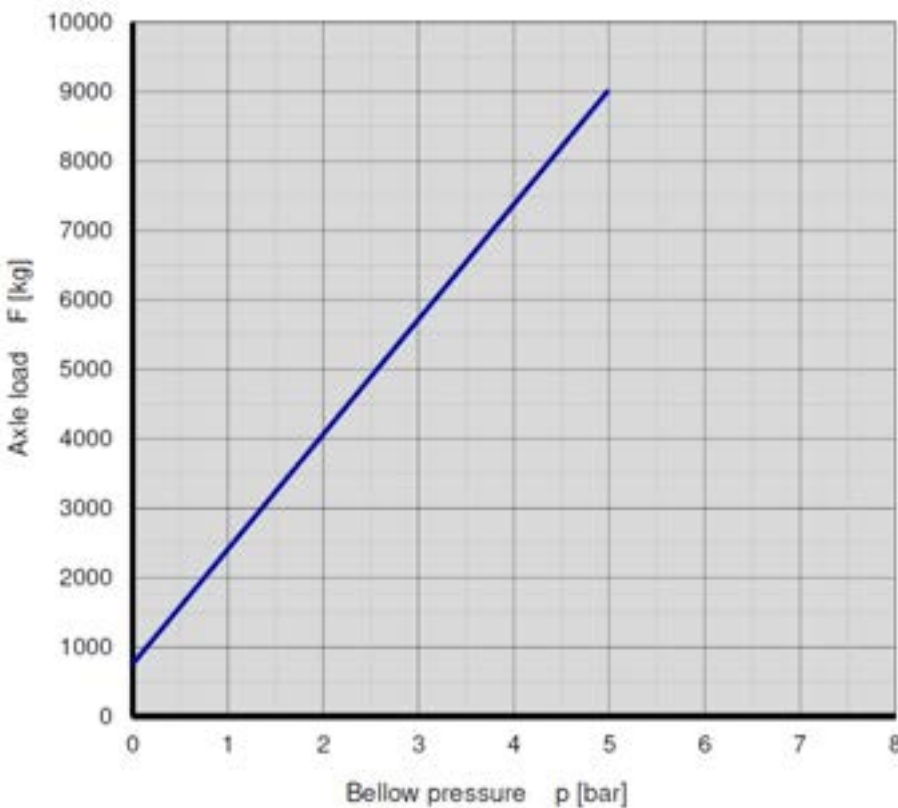

Assumed unsprung mass: 750 kg  
 Maximum axle load: 9 t  
 Reference numbers: US04110B.  
 US04235B.

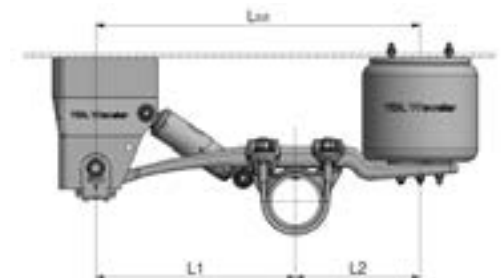

$$p = \frac{\text{axle load} - \text{unsprung mass}}{\text{geometry and air spring factor}} = \frac{F - 750}{1656}$$

Ltot = 845mm  
 L1 = 520 ± 10 mm  
 L2 = 325 ± 10 mm

This diagram is theoretical.  
 No rights can be claimed.

## 5. Air springs

### 5.8 Load-pressure diagram Ø350 air springs - 520-315 system geometry

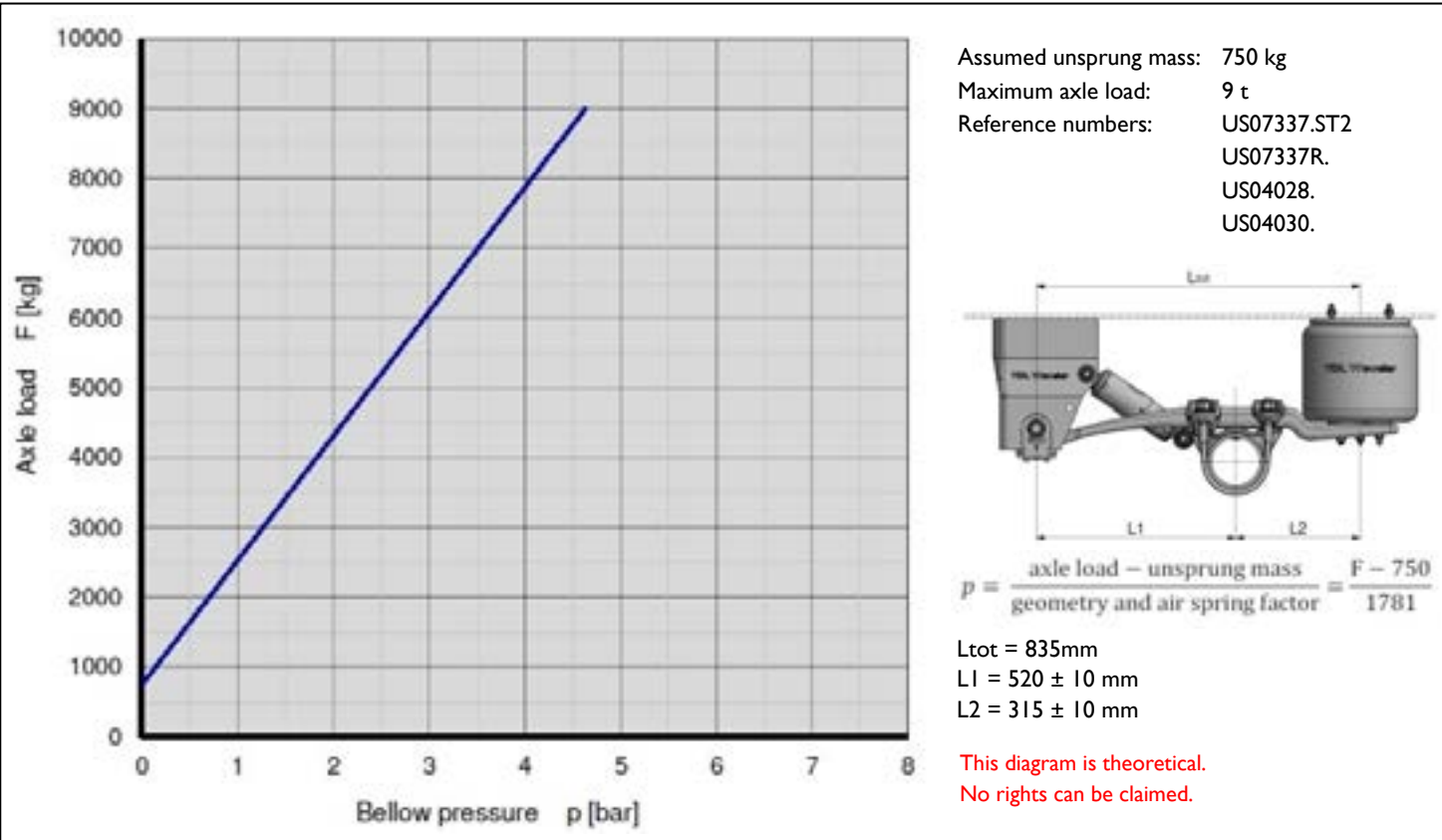

## 6. Shock absorber overview

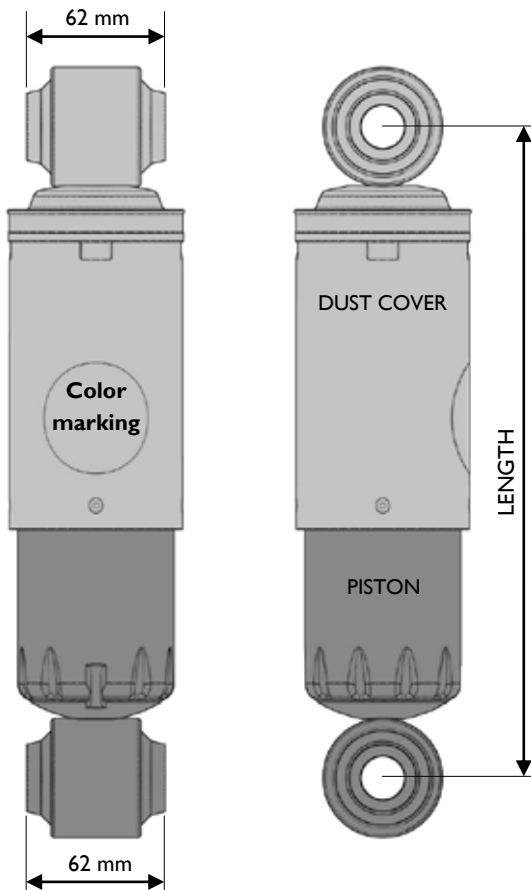

For the MBS-V/F air suspension range are four standard shock absorbers available. These can be identified based on the type number and color. The plastic dust cover are in both cases black. The color is applied on the complete bottom piston part of the shock absorber or by means of a colored sticker on the shock absorber.

Type	Color	Min. length	Max. length	Mounting
2244W	White	263 ± 3 mm	368 ± 3 mm	M20
2687W	Blue	275 ± 3 mm	387 ± 3 mm	M20
2643W	Black	294 ± 3 mm	429 ± 3 mm	M20
2640W	Orange	305 ± 3 mm	453 ± 3 mm	M20

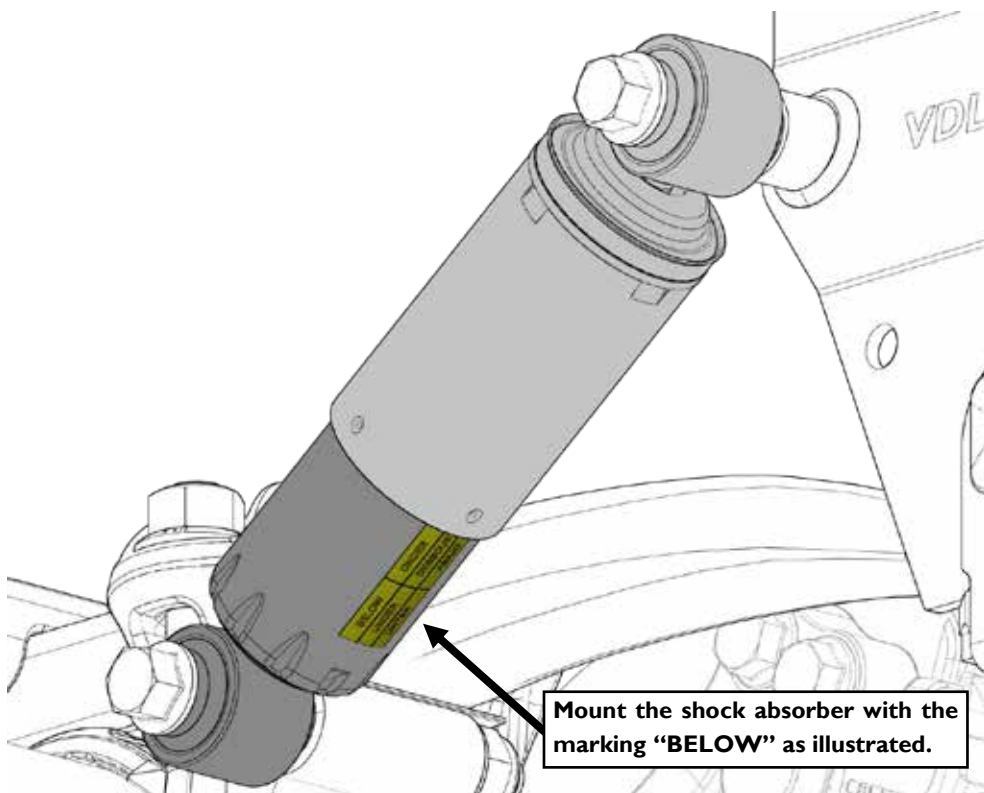

Mount the shock absorber with the marking "BELOW" as illustrated.

## 7. Alignment of system & axle

### 7.1 Alignment of air suspension versus axle

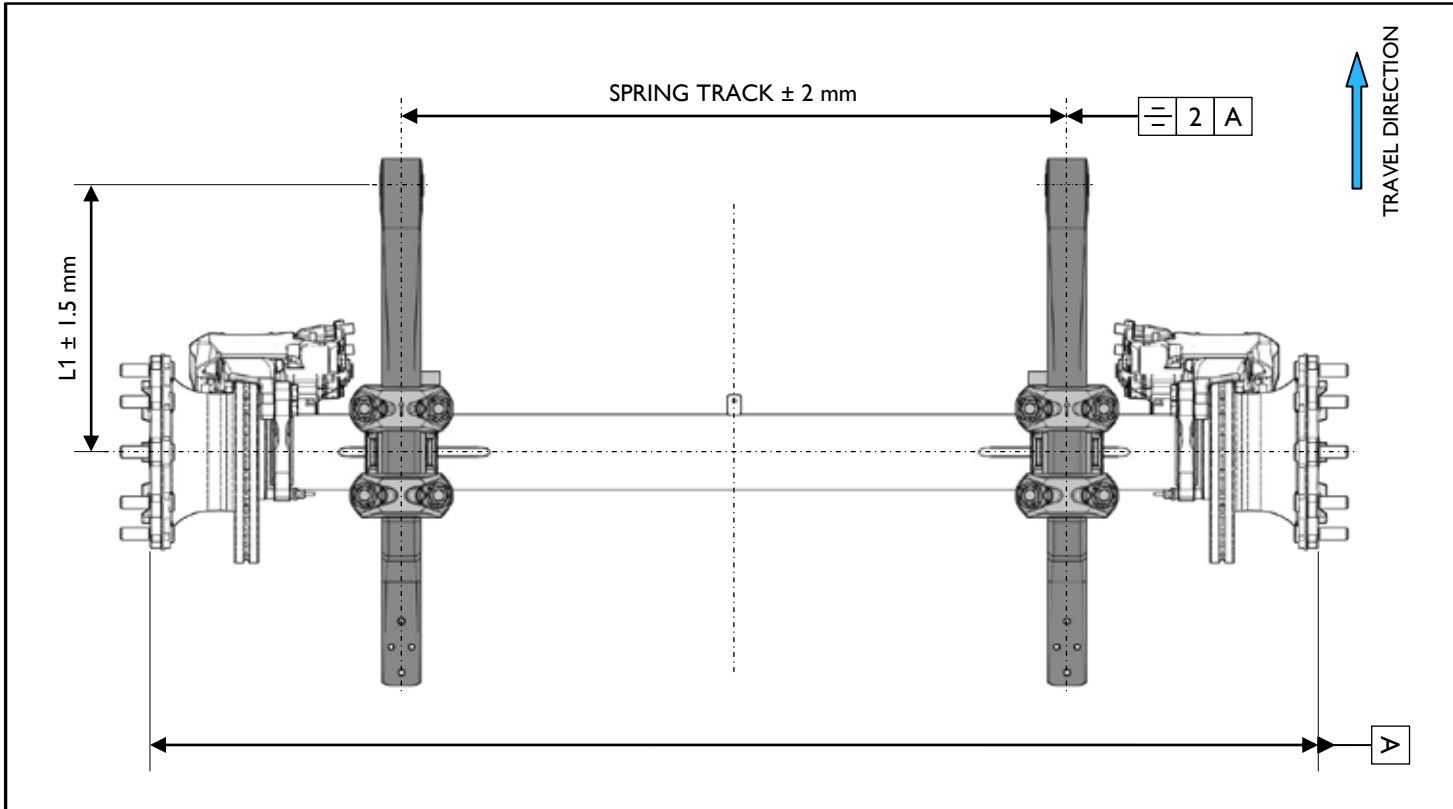

### 7.2 Alignment of trailing arm eye height

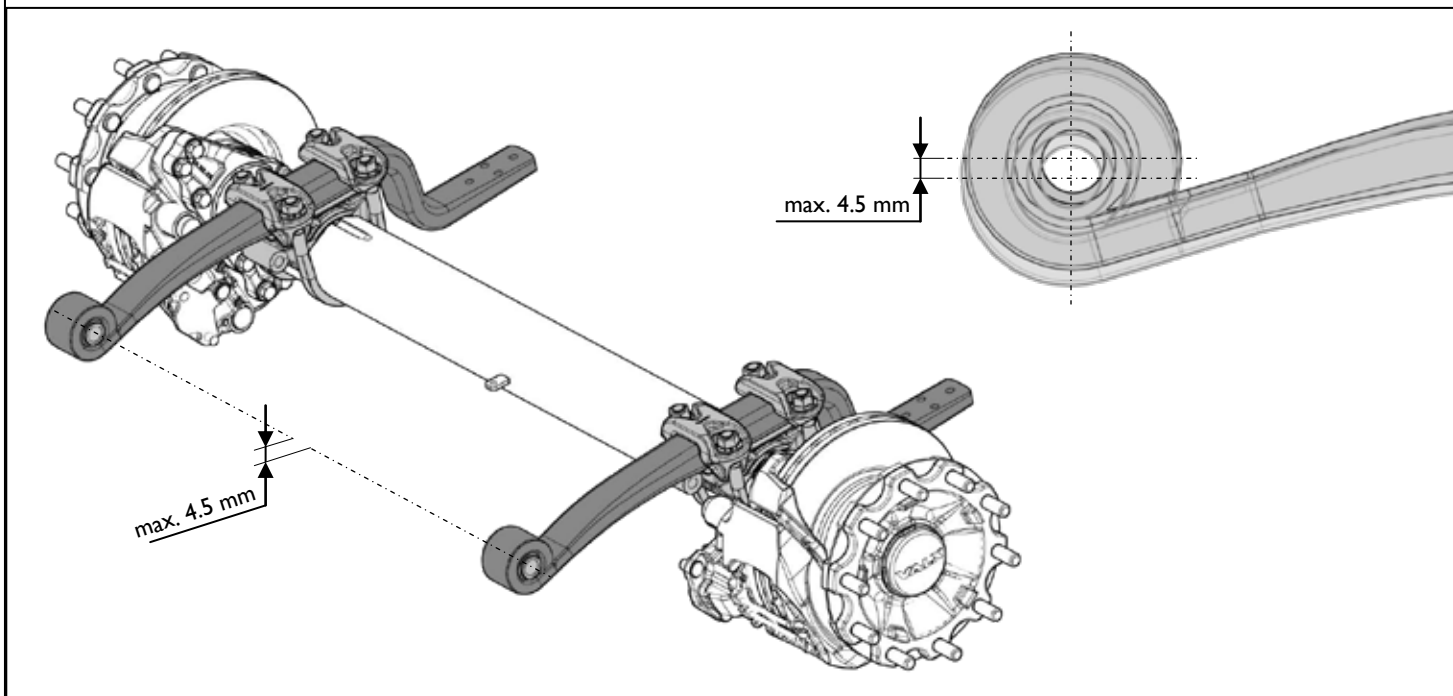

## 7. System & axle alignment

### 7.3 Alignment of axles

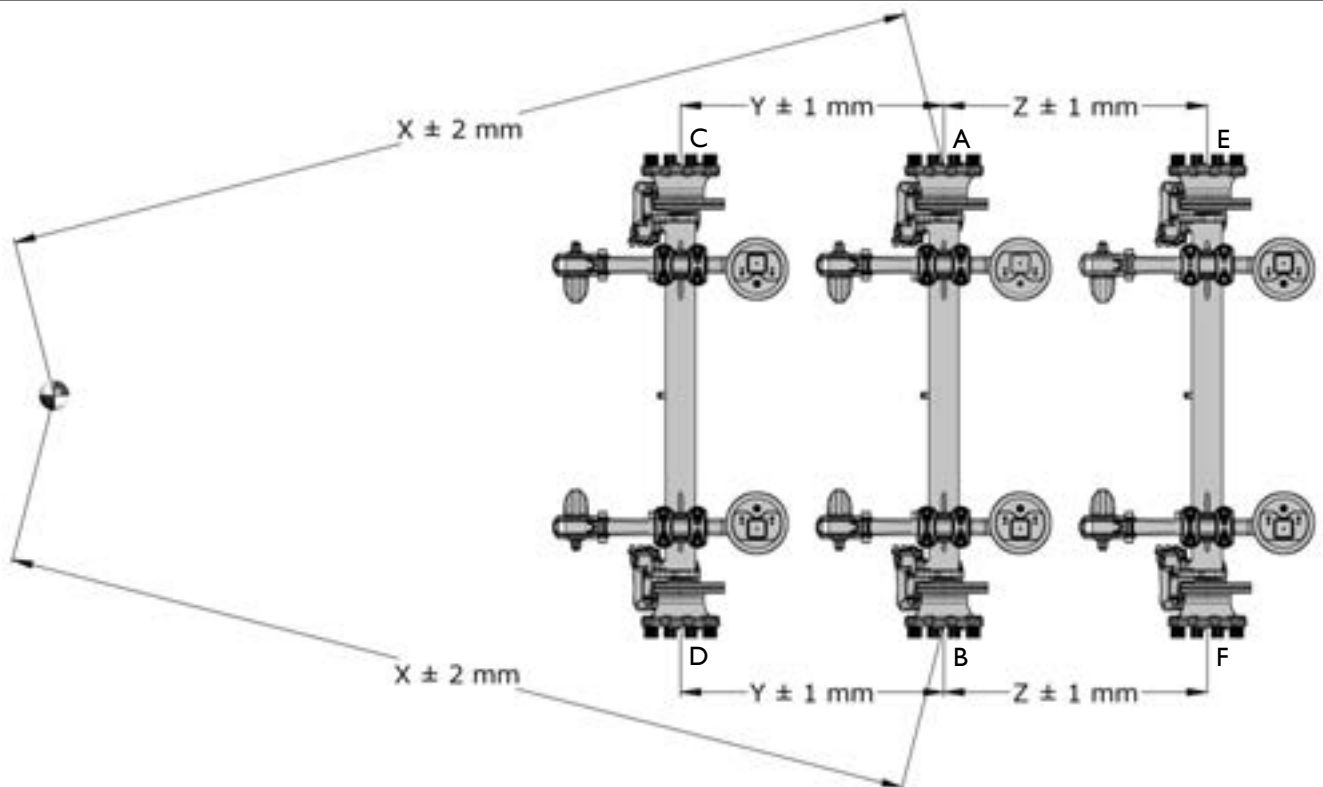

Align all axles (disc or drum) within the tolerances given, taken the second axle as a reference. The same tolerances apply for alignment using a laser. A through F are the axle centres.

### 7.4 Adjusting the hanger bracket alignment

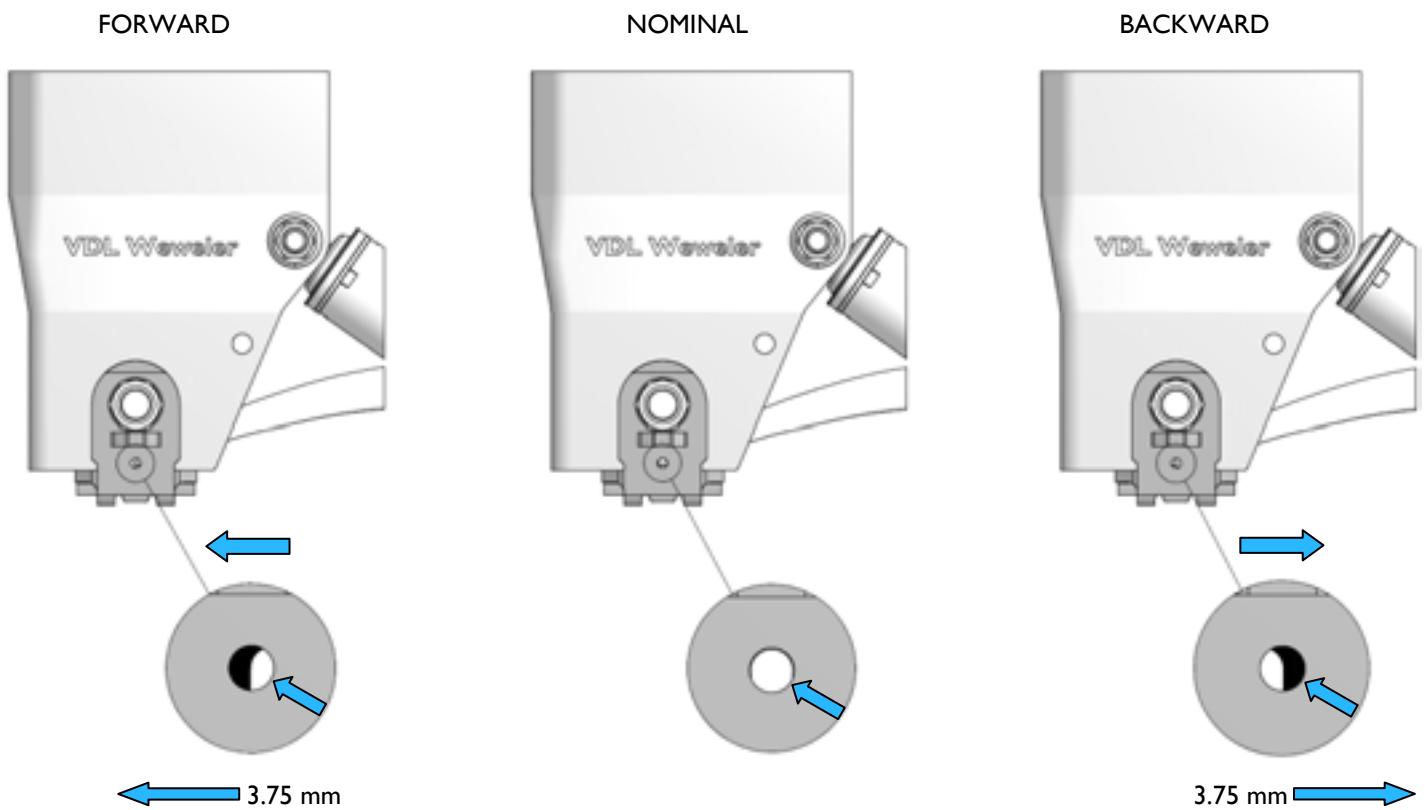

Due to slotted holes in the hanger bracket the pivot bolt and wear plates can move over 7 mm.

## 8. Paint instruction

The red marked areas are only allowed to be primered, KTL coated (max. 30µm) or zinc dipped (50 - 100µm).

Hanger bracket (both types)

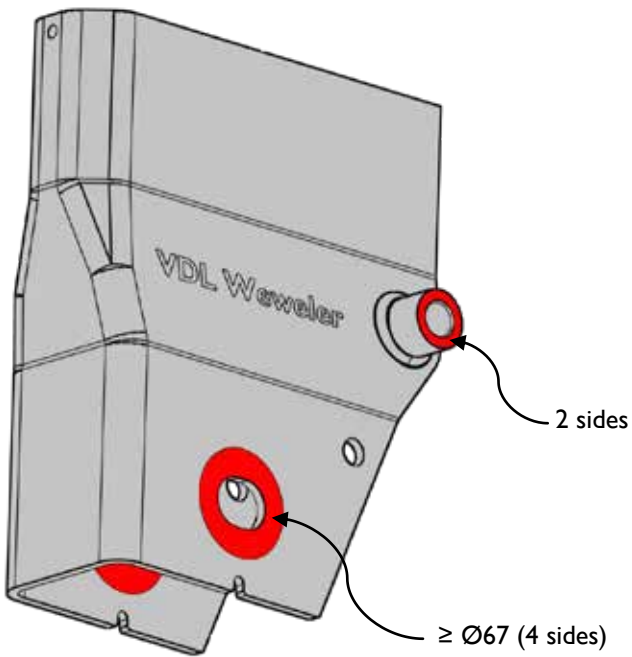

Wear plate (standard already KTL coated)

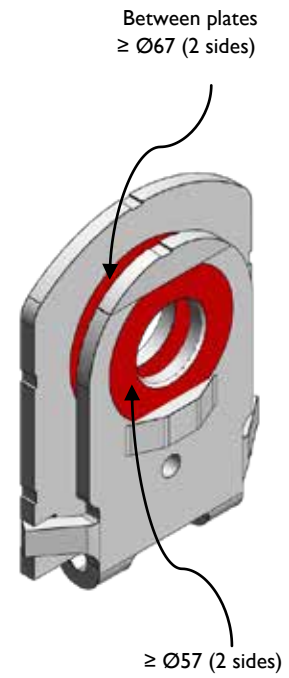

Trailing arm

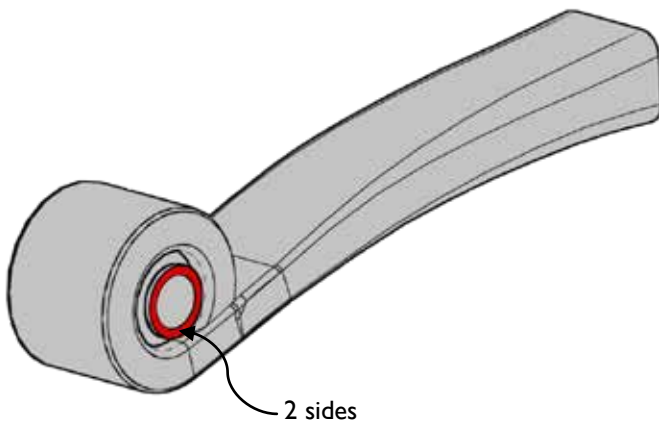

Shock absorbers

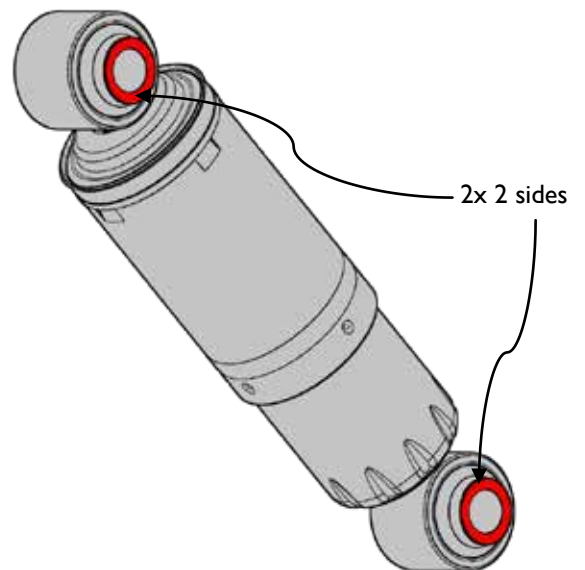

## 9. Axle lift

For the MBS-V air suspension range are two axle lifts, each in two configurations (high and low bump), available. Both can be retro-fitted. Please check the available individual system drawings for the required correct axle lift version. All versions are suitable for disc and drum brake axles. Maximum allowed pressure is 8,5 bar. No residual pressure is needed when the axle is not lifted. Per axle two axle lifts are required. For MBS-F range different axle lifts may be required. Please check individual system drawing for suitable type of axle lift.

### 9.1 Axle lift versions (MBS-V)

AL-478-II - Version 1 - High bump

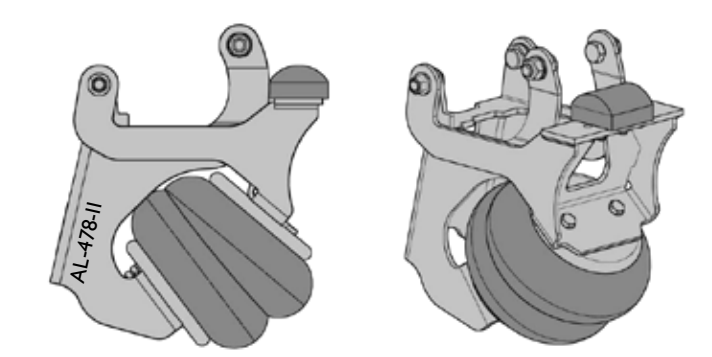

AL-484-II - Version 1 - High bump

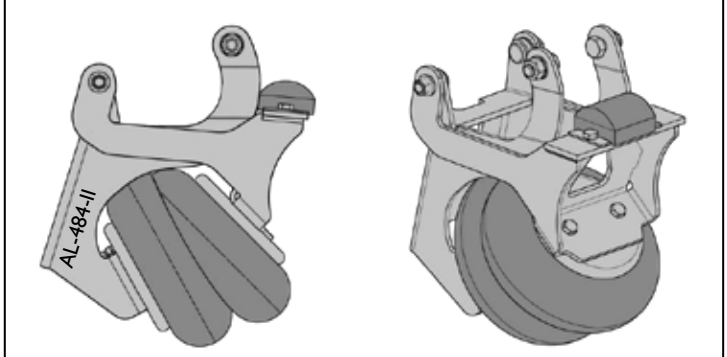

AL-478-II - Version 2 - Low bump

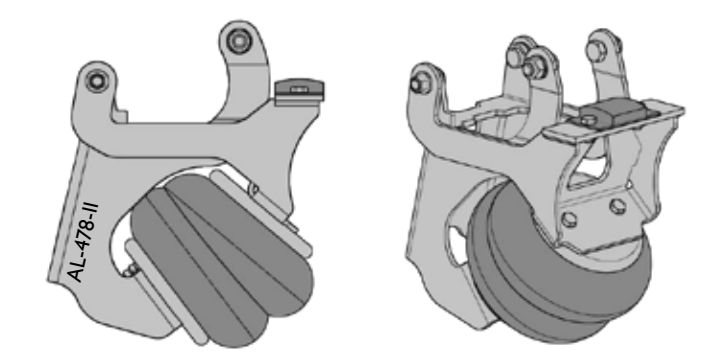

AL-484-II - Version 2 - Low bump

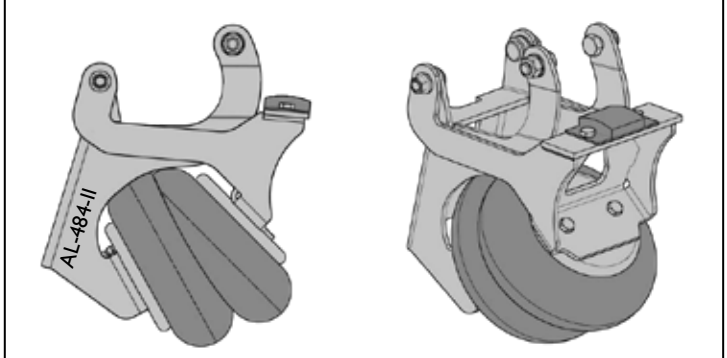

### 9.2 Axle lift clearance

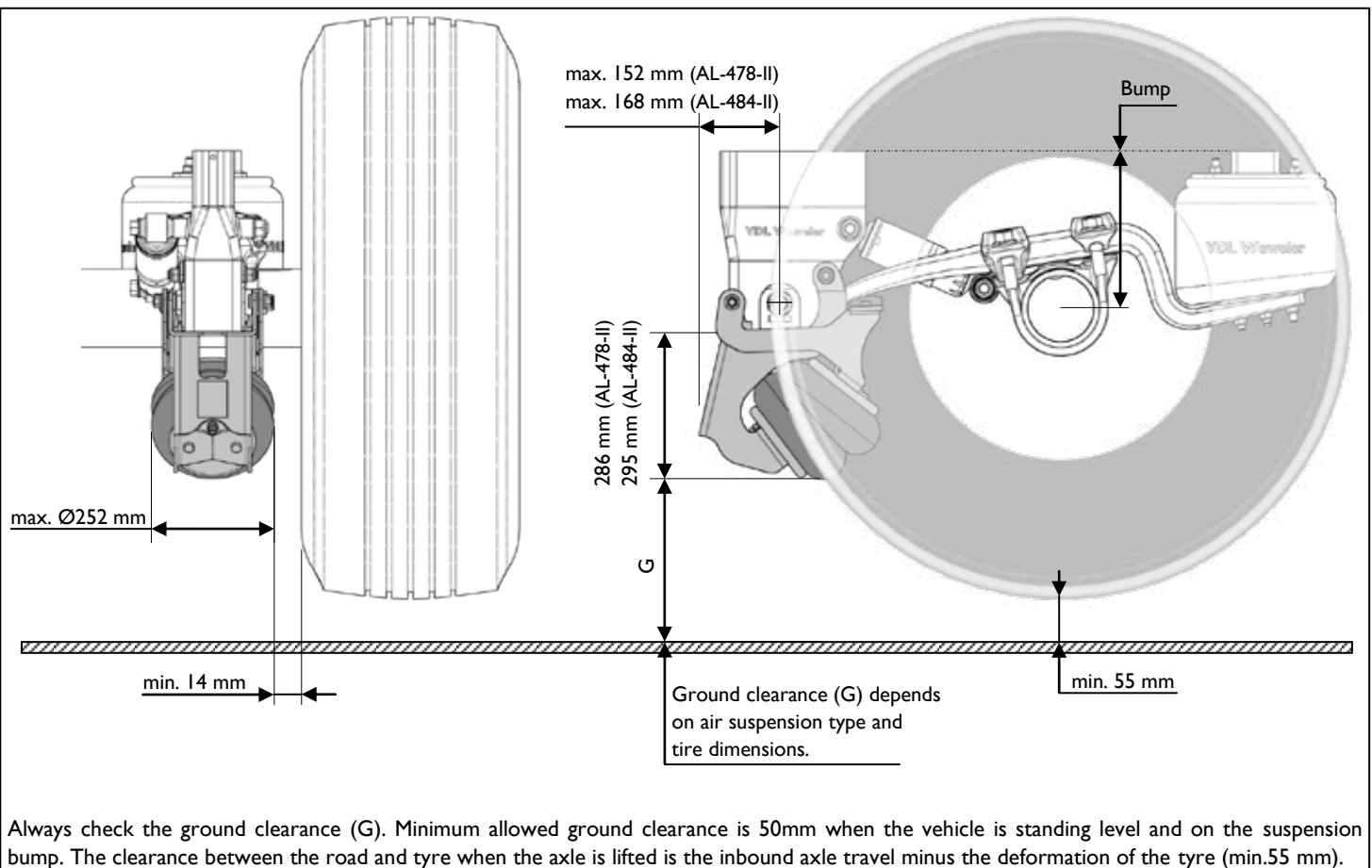

Always check the ground clearance (G). Minimum allowed ground clearance is 50mm when the vehicle is standing level and on the suspension bump. The clearance between the road and tyre when the axle is lifted is the inbound axle travel minus the deformation of the tyre (min.55 mm).

## 10. Torque settings MBS-V/F Air Suspension

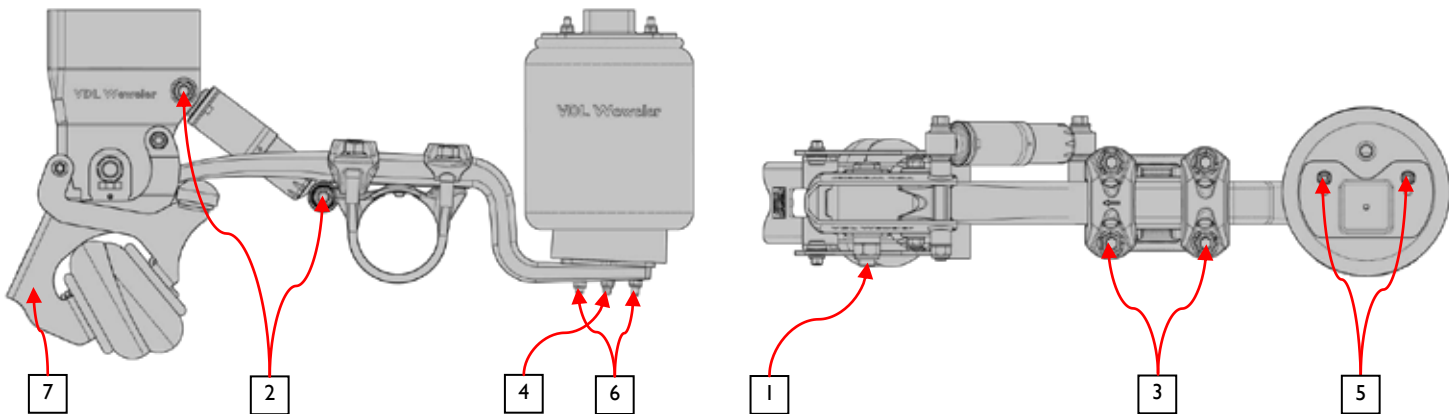

Item	Size	Width across flats (A/F)	Torque **		Inspection Field check (maintenance)
			Step 1 : Torque	Step 2 : Angle	
<b>1</b> Pivot bolt <sup>1) 2)</sup>	M27	41	250 Nm (+25 / -0) + apply grease on 1/4 of thread surface *	250° (+27° / -13°) <sup>4)</sup> 270° (+27° / -13°) <sup>4)</sup>	1000 Nm
<b>2</b> Shock absorber <sup>1) 2)</sup>	M20	24 (bolt) / 30 (nut)	200 Nm (+20 / -0)	180° (+18° / -9°)	550 Nm
<b>3</b> U-bolts <sup>3)</sup>	M22	32	600 Nm (+25 / -0)	-	600 Nm
<b>4</b> Air spring (bottom)	M12	19	65 Nm (+10 / -0)	-	65 Nm
<b>5</b> Air spring (top)	M12	19	30 Nm (+10 / -0)	-	30 Nm
	Air spring (top - combo-stud)	M22	32	65 Nm (+0 / -15)	-
<b>6</b> Air spring support plate	M12	19	65 Nm (+10 / -0)	-	65 Nm
<b>7</b> Axle lift (pre-assembled)	M16	24	200 Nm (+/- 20)	-	200 Nm

<sup>1)</sup> Tighten at ride height.

<sup>2)</sup> During angle tightening of the nut/bolt it is essential to secure the counterside.

<sup>3)</sup> Tighten U-bolts evenly and crosswise.

<sup>4)</sup> For T(W) hanger bracket use 250°, for CW hanger bracket use 270°.

Always tighten or check the fasteners with a calibrated torque wrench.

### \* 1/4 THREAD SURFACE GREASE

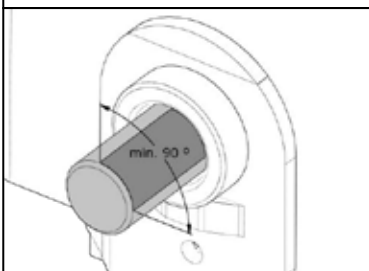

Grease specification:  
DIN51 502, KPHC 2 P-30

### \*\* ANGLE TIGHTENING METHOD (example pivot bolt)

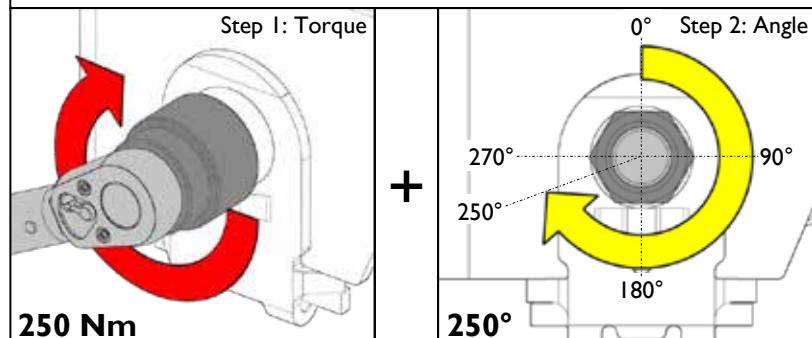



## 11. Air Suspension Assembly

### 11.1 Assembly Jig

Set up assembly jig for corresponding axle. The outer supports enclose the axle by positioning them against the hubfaces. Make sure the center rolling supports do not interfere with any axle or suspension components. The illustrated jig is equipped with a self centering mechanism which ensures that the axle is positioned exactly in the middle of the assembly jig. Adjust the front supports to the correct spring track.

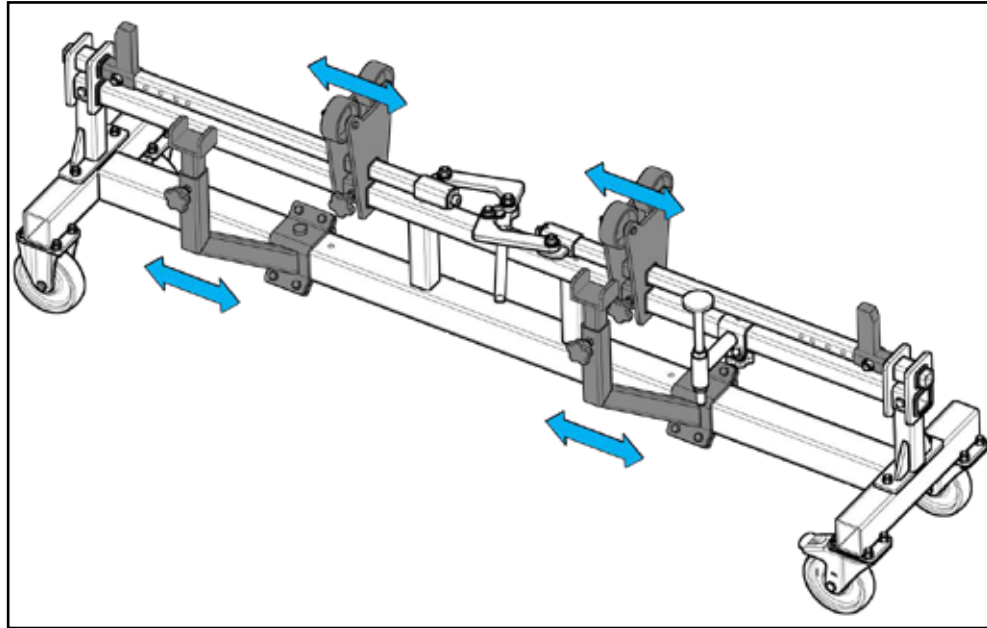

### 11.2 Axle

Place the axle on the assembly jig. Close the self centering mechanism. The axle is enclosed by the outer supports.

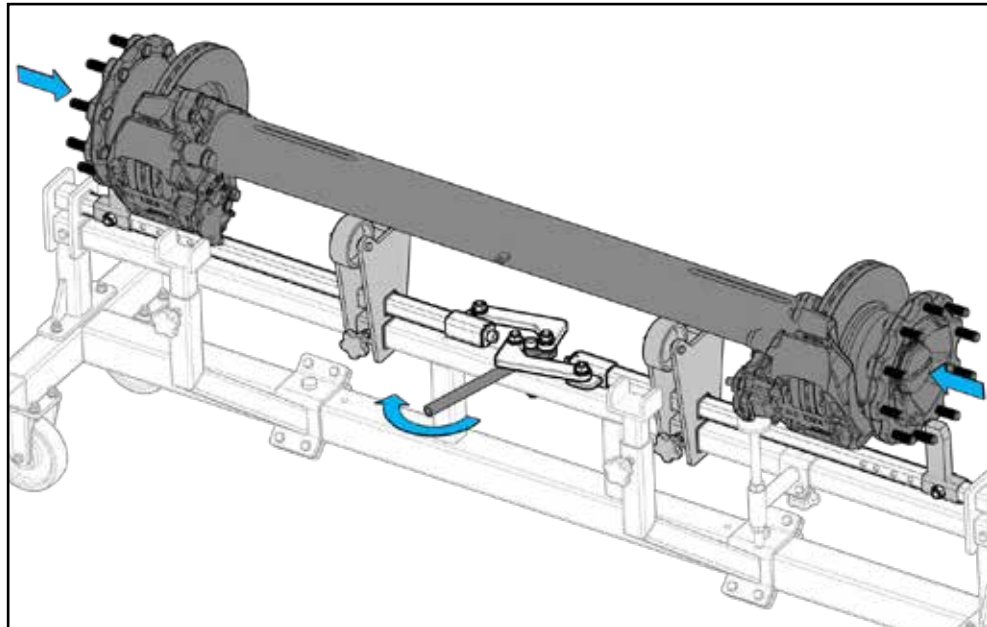

### 11.3 Axle position

Rotate the axle to position the groove to the **twelve o'clock position as indicated.** Support the brake (caliper in case of disc brake axle or camshaft in case of drum brake axle) with the separate support bracket to avoid the axle from rotating during the assembly.

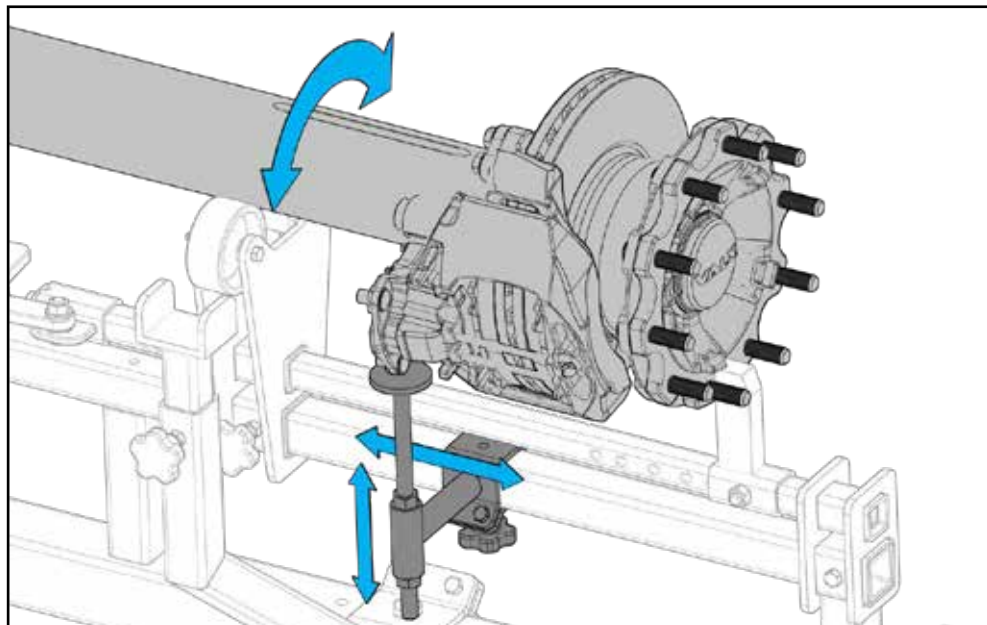

## 11. Air Suspension Assembly

### 11.4 Axle clamping

Place the axle seat over the groove. Make sure it is positioned firmly in the groove in the axle. The shock absorber tube must be positioned on the vehicle inside.

Next place the zinc plate on the axle seat and place the dowel through the zinc plate and in the hole at the rear of the axle seat.

Follow the same steps for the other side.

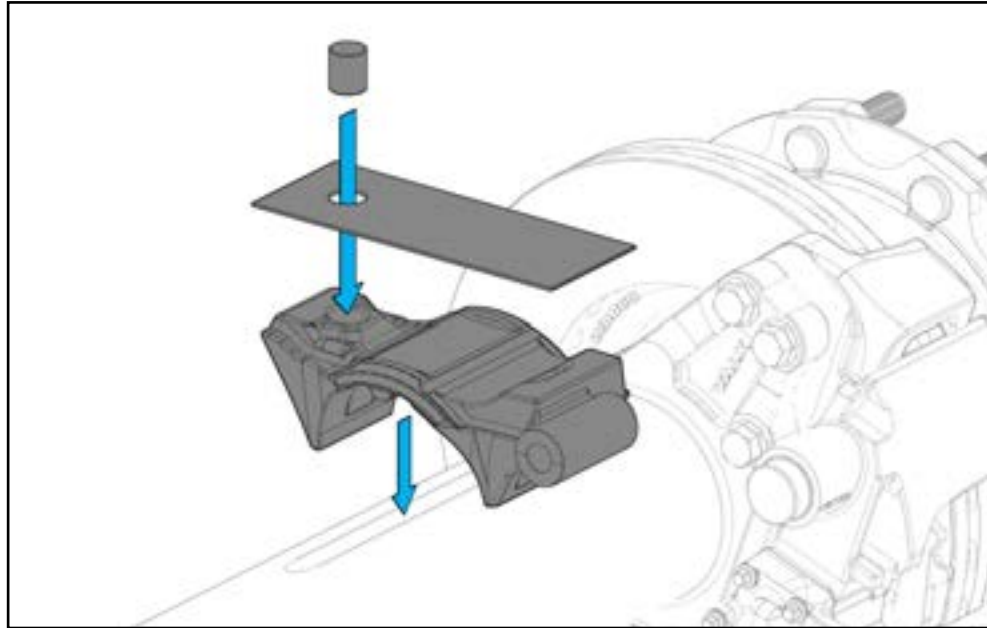

### 11.5 Trailing arms

Place the trailing arm on the zinc plate, make sure the dowel falls in the hole at the back of the clamping area in the trailing arm. Pull the trailing arm to the front.

Adjust the trailing arm support brackets on both sides to support the trailing arm. Make sure the trailing arm is not lifted of the zinc plate at the front side of the clamping because this can affect the tightening at a later stage.

Finally place the both u-bolt plates over the trailing arm. Place the u-bolt plate with the long legs at the front and with the arrow pointing in the travel direction.

Follow the same steps for the other side.

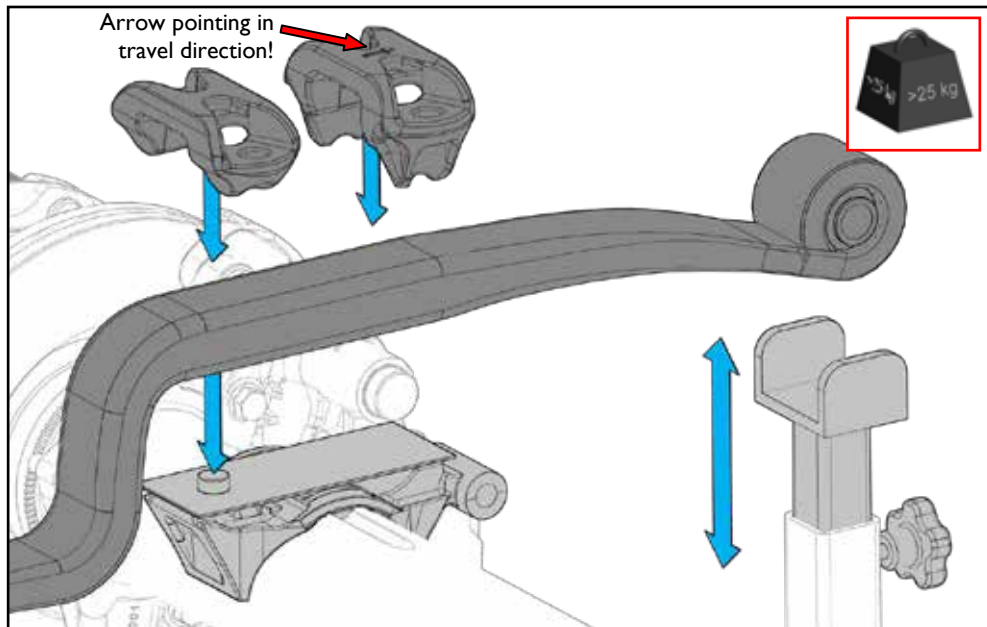

### 11.6 U-Bolts

Place the u-bolts around the axle and through the u-bolt plates and tighten the nuts slightly (hand tighten) until the u-bolts are positioned against the axle tube.

Repeat the same procedure for the other side.

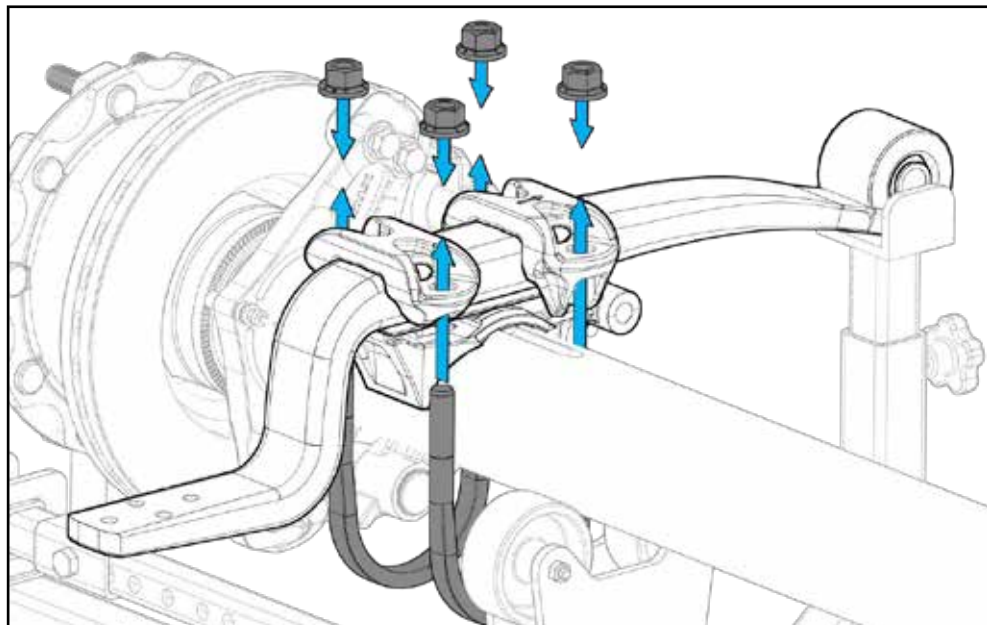

## 11. Air Suspension Assembly

### 11.7 Spring track

Check the spring track again by measuring the distance through the spring eyes. In this example the spring track is 1300mm. When using the illustrated assembly jig this should be already correct, but always check.

If necessary adjust the spring track to the correct track by moving the clamping left or right over the groove.

See instructions: Section 7.1 & 7.2

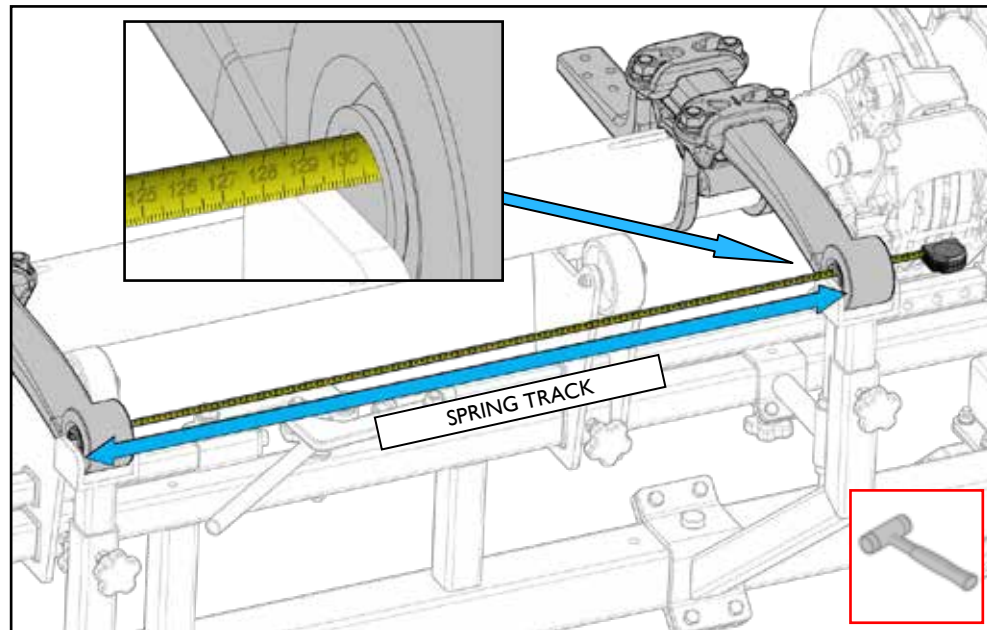

### 11.8. Alignment suspension to axle

Check the distance between the trailing arm eye and the hubface on both sides of the axle. This dimension should be the same on both sides.

When using the illustrated assembly jig this should be already correct, but always check.

If necessary adjust the alignment by moving both clamping sides left or right over the groove.

See instructions: Section 7.1 & 7.2

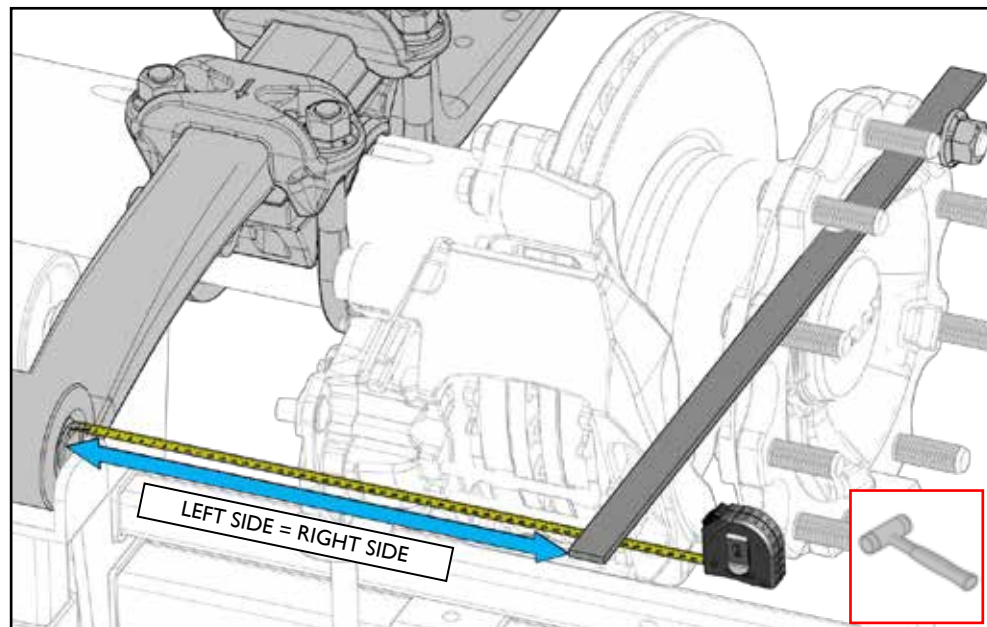

### 11.9. Tighten U-Bolts

Tighten the U-bolts crosswise and evenly on both sides.

After tightening check if the dimensions from step 11.7 and 11.8 are within tolerance.

See tightening instructions: Section 10

Alternative method:

Tighten the U-bolts crosswise and evenly to maximal 200Nm, paying attention to little movement of the clamping parts and even thread lengths above the nuts.

When using an electronic torque gun next tighten crosswise to 300Nm. Check if the dimensions from step 11.7 and 11.8 are within tolerance. Correct little deviations by ticking against the rear of the trailing arm. Finally tighten crosswise to 600Nm.

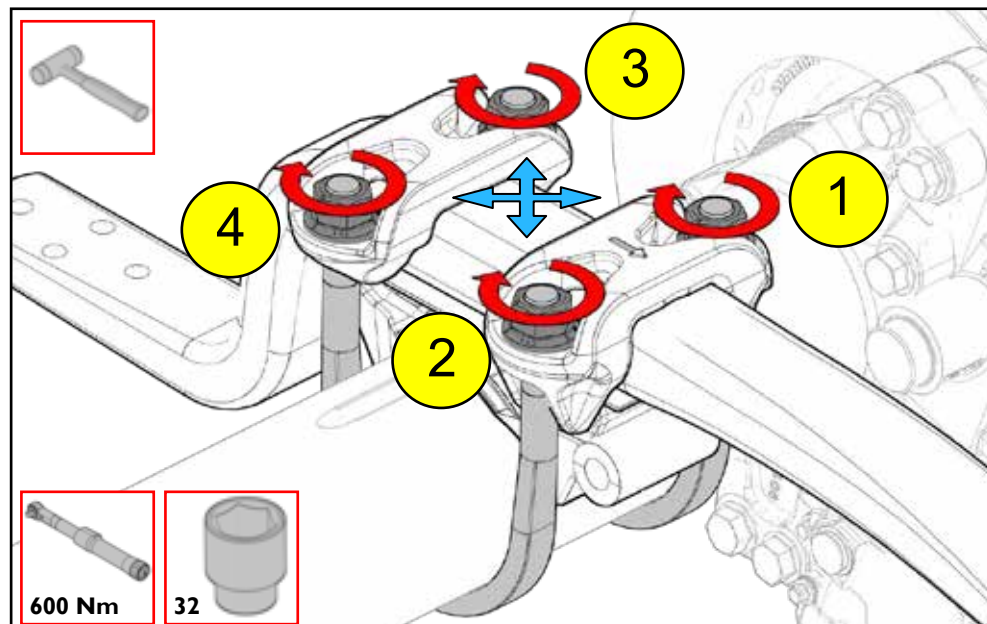

## 11. Air Suspension Assembly

### 11.10a Air spring Ø300 offset 20 mm

First mount the air spring support plate correctly orientated for the Ø300/Ø335 air springs on the 75 or 95 mm wide trailing arm with the countersunk M12 bolts and locknuts. Torque the M12 locknuts.

Next hand tighten the M12 stud in the air spring until it is fastened (at least 8 thread/wire runs). Then place the air spring with stud through the center hole of the air spring support and the trailing arm. Torque the M12 locknut.

Make sure the upper air spring mounting studs and air inlet are in the correct position.

*See tightening instructions: Section 10*

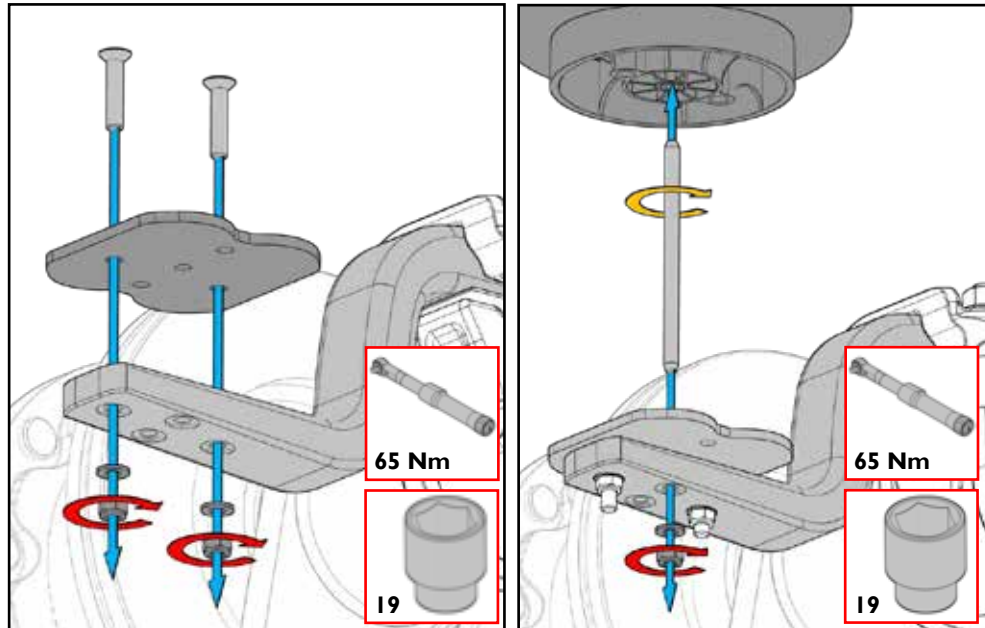

**This installation guide shows the standard Ø300 air spring with 20mm offset plate. Other available air spring (offset) options can be found in section 13 of this manual.**

### 11.11 Axle & suspension assembly

Air suspension assembly on the grooved axle complete and ready for mounting on the chassis.

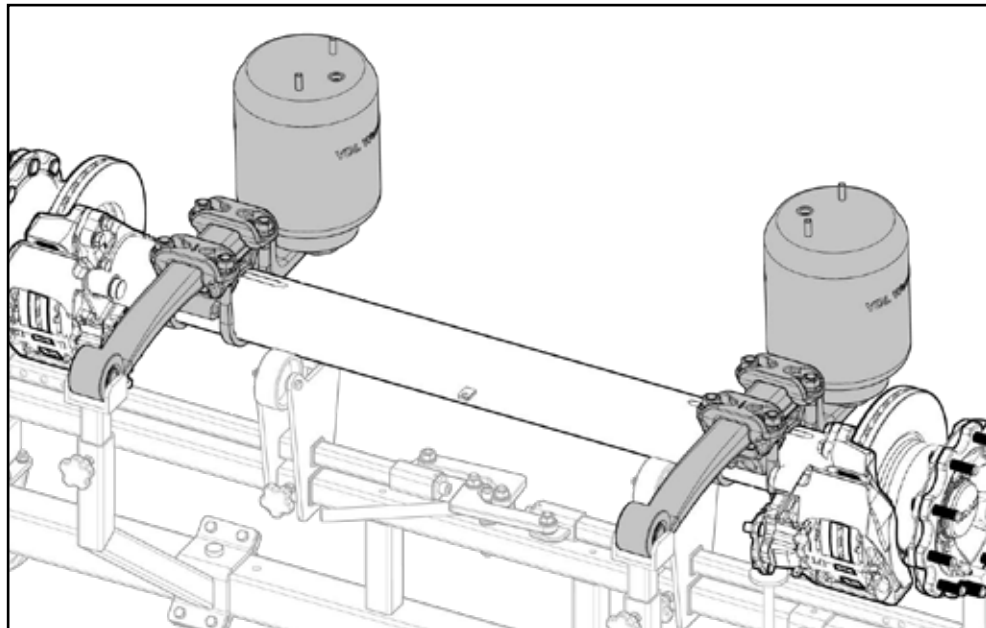

## 12. Chassis Mounting - Plate bracing (steps 12.1 - 12.2) / Casted bracing (steps 12.3-12.5)

Two types of hanger bracket bracing are possible depending on the type of vehicle (see Section 4.6 & 4.7). Please follow steps 12.1 through 12.2 for the welded plate bracing and for the welded casted bracing follow steps 12.3 through 12.5.

### 12.1 Hanger brackets

Align and weld the hanger brackets to the chassis rails according instructions at the correct spring track.

The trailer builder is responsible that there are sufficient reinforcements in the vehicle chassis to guide the occurring forces on the hanger brackets.

*See instructions: Section 4.3*

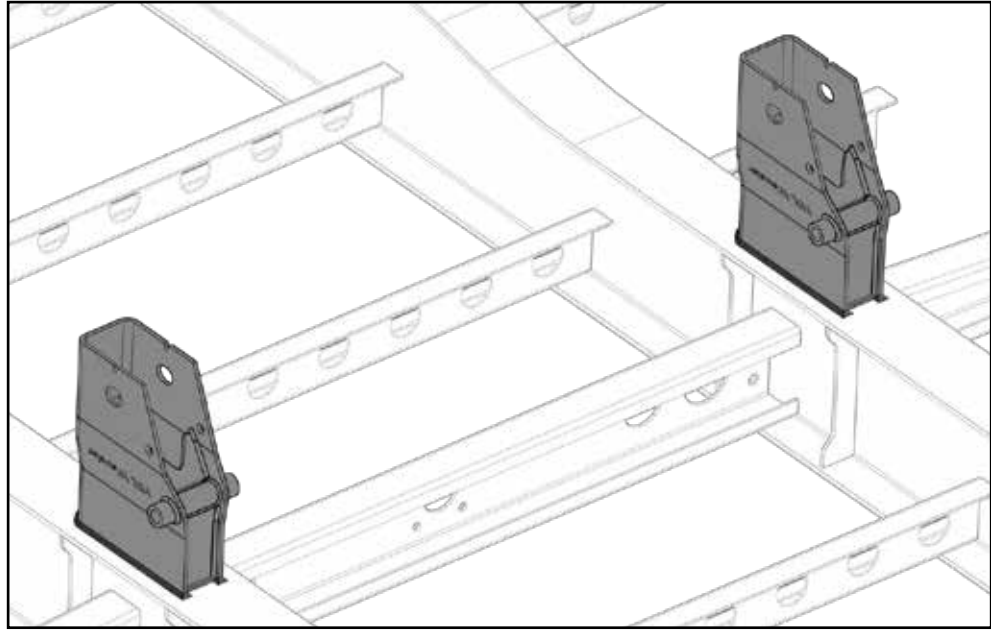

### 12.2 Welded plate bracing

Weld the bracing plates to the hanger brackets and the cross members in the chassis according instructions.

The plates must be straight and are not allowed to be bended.

*See instructions: Section 4.6*

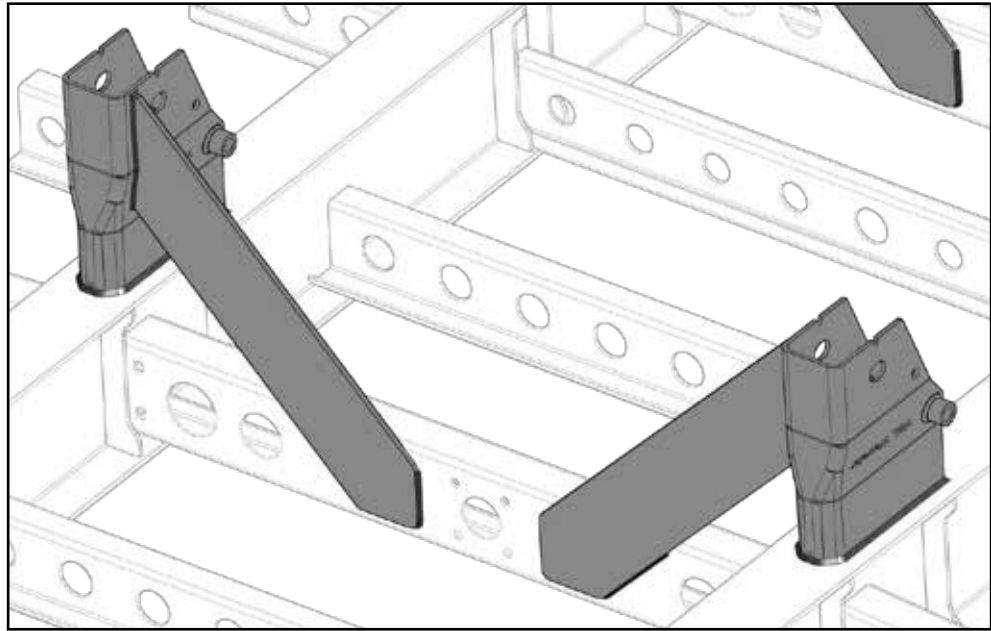

**GO TO STEP 12.6**

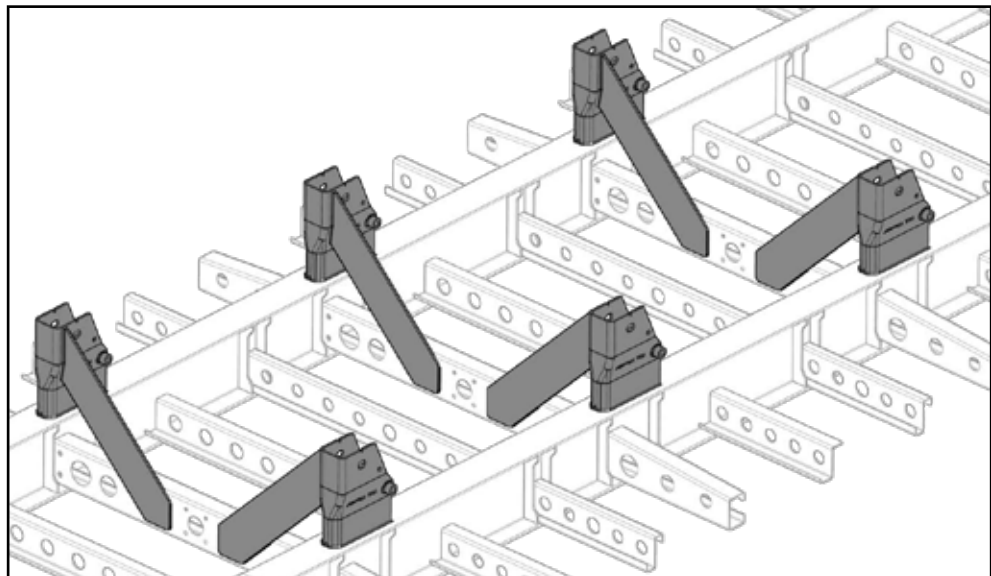

## 12. Chassis Mounting

### 12.3 Hanger bracket & casting

Weld the casted bracing part to the hanger bracket according instructions.  
Make per axle a lefthand and righthand version.

*See instructions: Section 4.7*

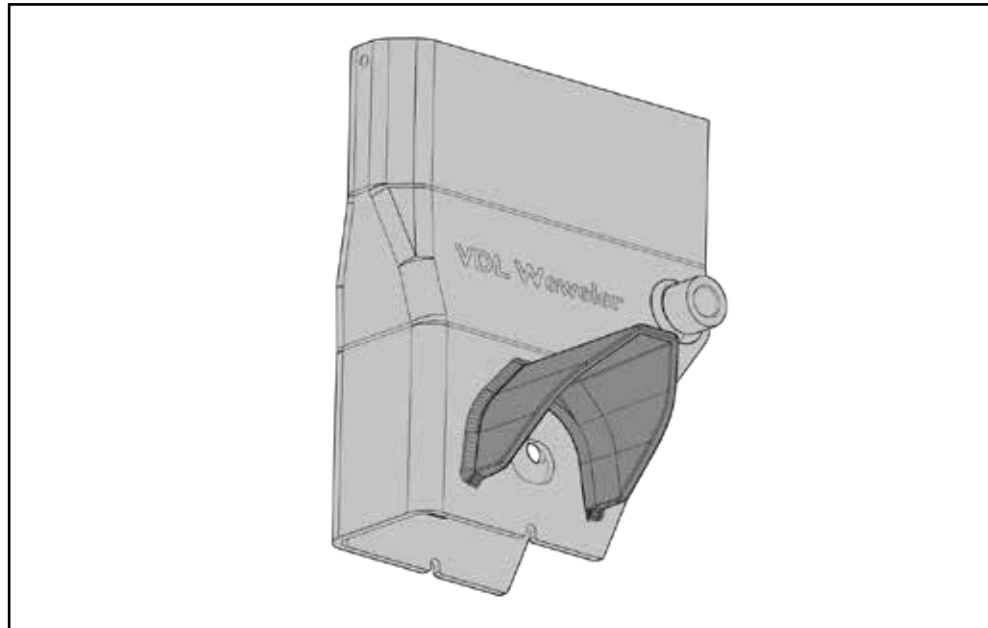

### 12.4 Hanger brackets

Align and weld the hanger brackets to the chassis rails according instructions at the correct spring track.

The trailer builder is responsible that there are sufficient reinforcements in the vehicle chassis to guide the occuring forces on the hanger brackets.

*See instructions: Section 4.3*

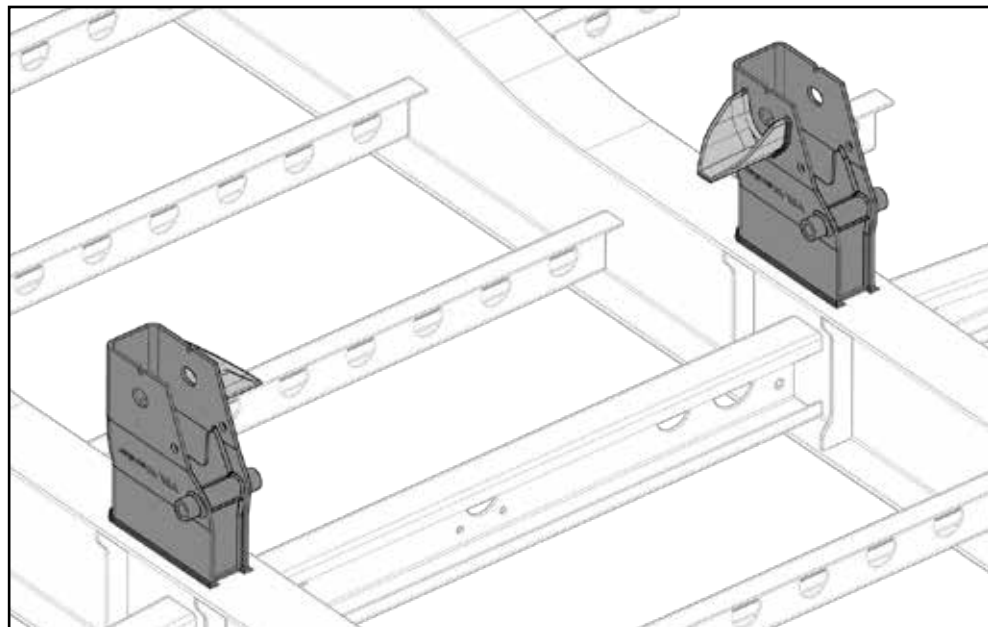

### 12.5 Bracing plates

Weld the bracing plates to the casted bracing parts and the cross members in the chassis according instructions.

The plates must be straight and are not allowed to be bended.

*See instructions: Section 4.7*

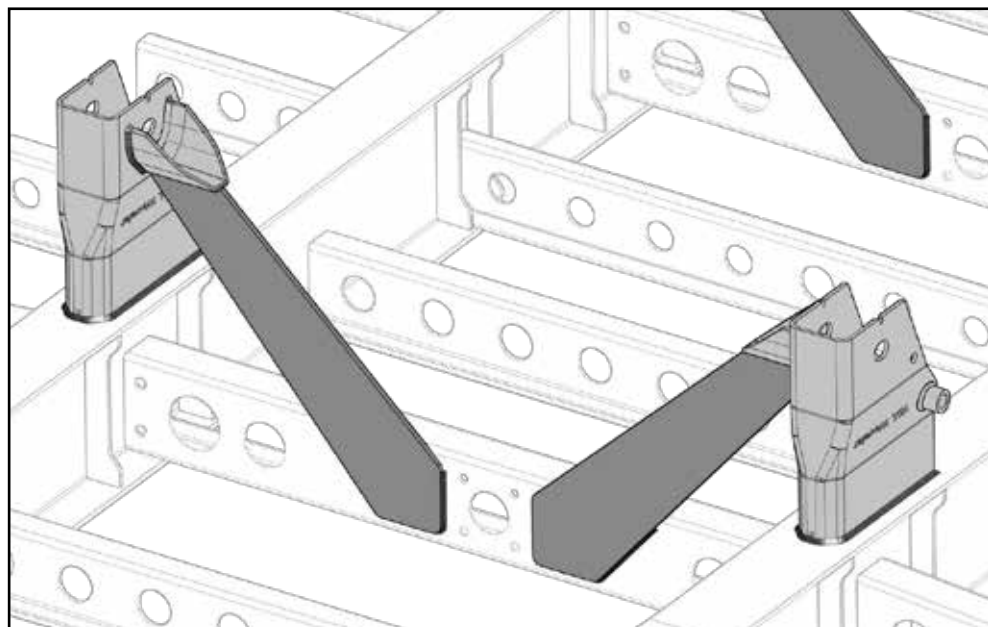

## 12. Chassis Mounting

### 12.6 Pedestals

Weld the pedestals (if present in the suspension assembly) to the chassis rails according instructions.

The universal pedestal is suitable for the Ø300 and Ø335 air spring. Check the system drawing for the correct air spring offset.

The trailer builder is responsible that there are sufficient reinforcements in the vehicle chassis to guide the occurring forces on the pedestals.

*See instructions: Section 4.5*

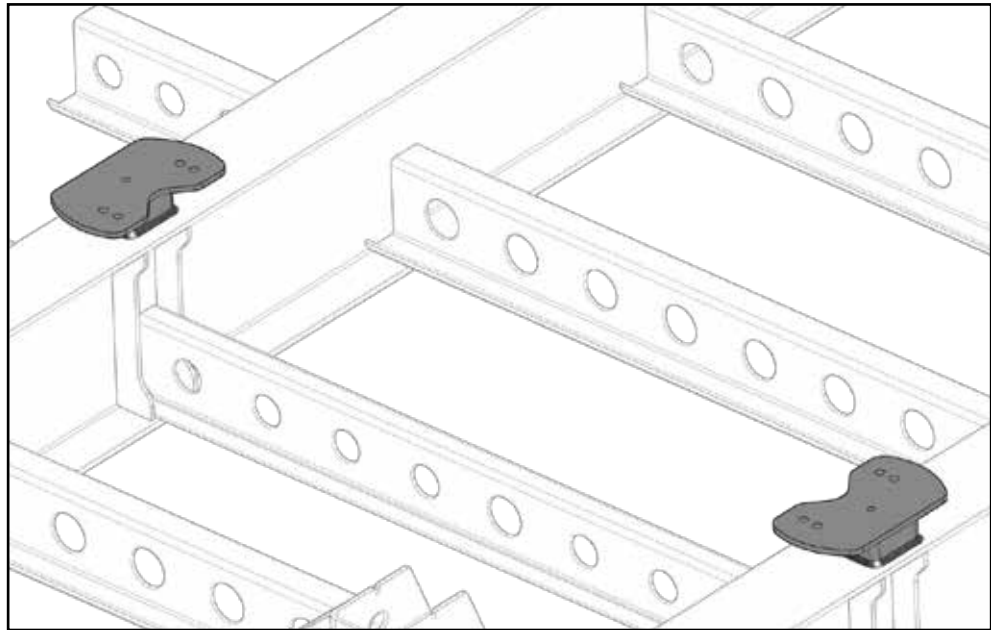

### 12.7 Coating / painting

The complete chassis can be painted/coated before mounting the assembled suspension.

See instructions for areas which must be free from paint/coating or only can be primed.

*See instructions: Section 8*

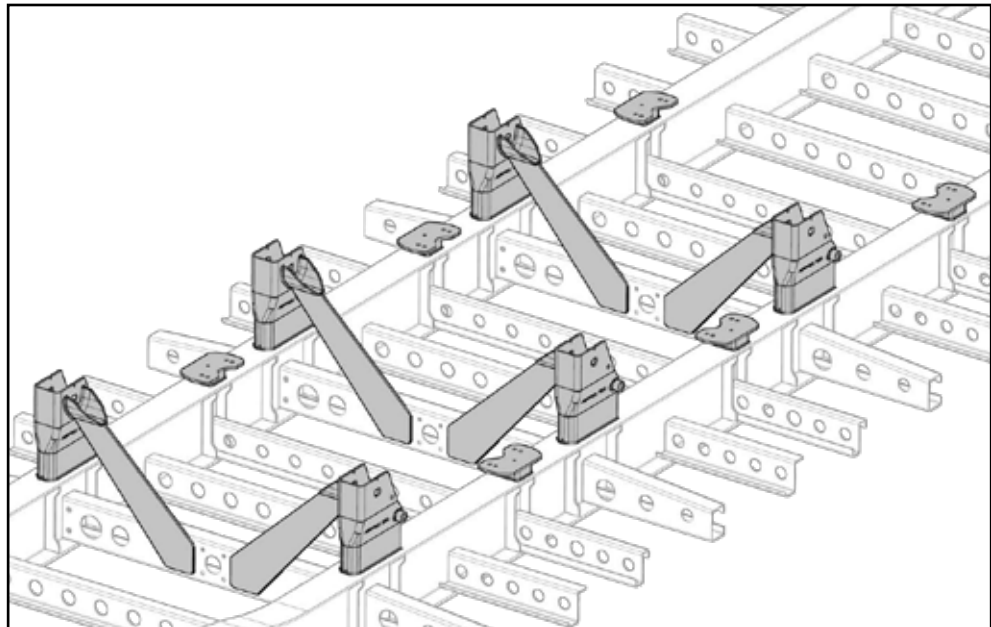

### 12.8 Wear/alignment plates

Place the wear/alignment plates over bottom edges of the hanger brackets.

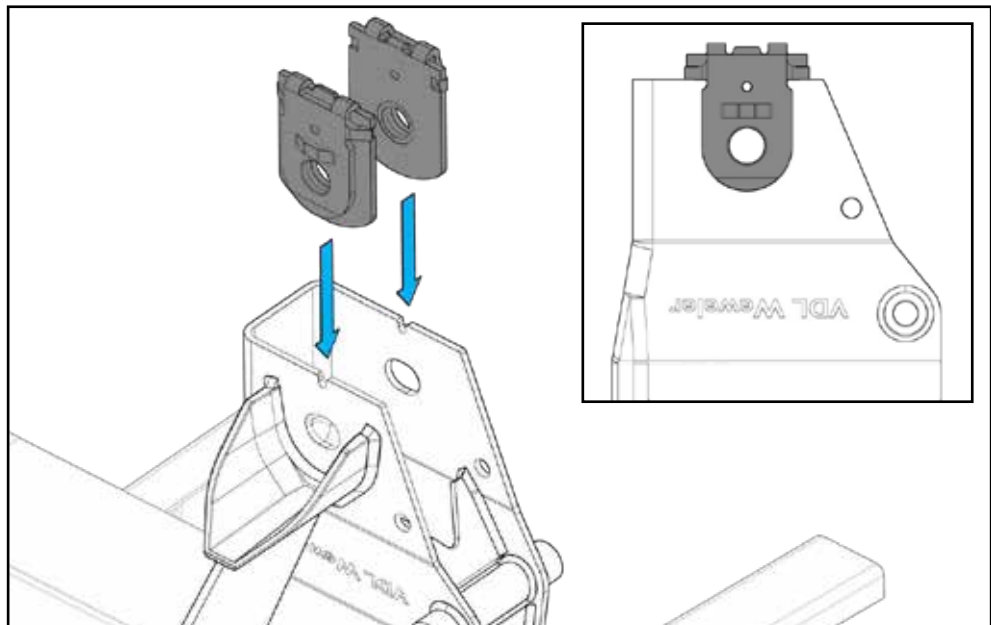

## 12. Chassis Mounting

### 12.9 Axle placement

Place the assembled axles in the hanger brackets between the wear plates and place the pivot bolt connection. Hand tighten the nut. After alignment (step 12.10) the connection can be torqued.

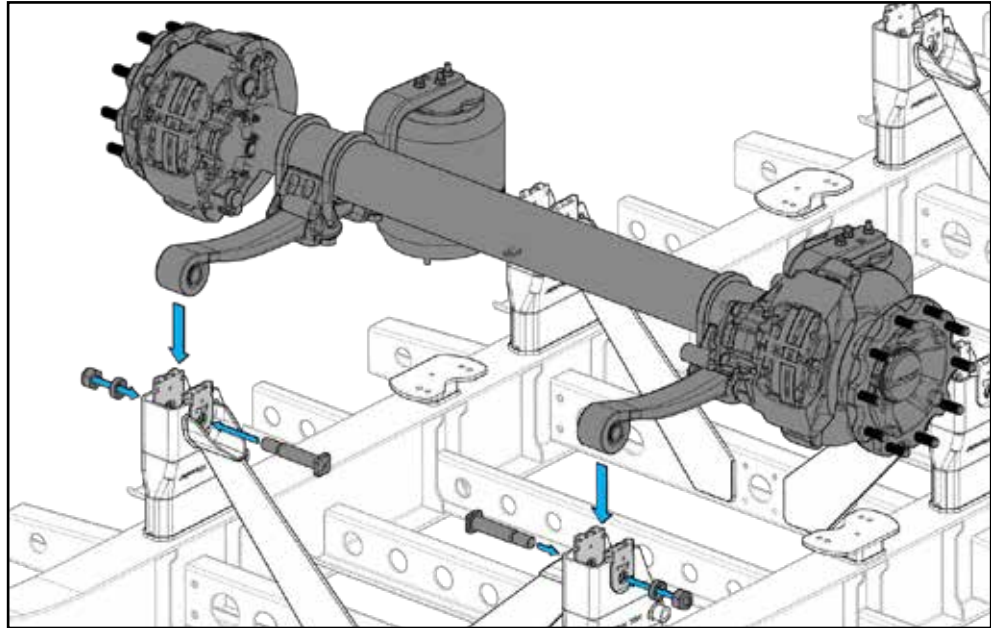

### 12.10 Axle alignment

Align all axles (disc or drum) within the tolerances given, taken the second axle as a reference.

The same tolerances apply for alignment using a laser.

A through F are the axle centres.

*See instructions: Section 7.3*

Follow instructions for adjusting the alignment in the hanger bracket.

*See instructions: Section 7.4*

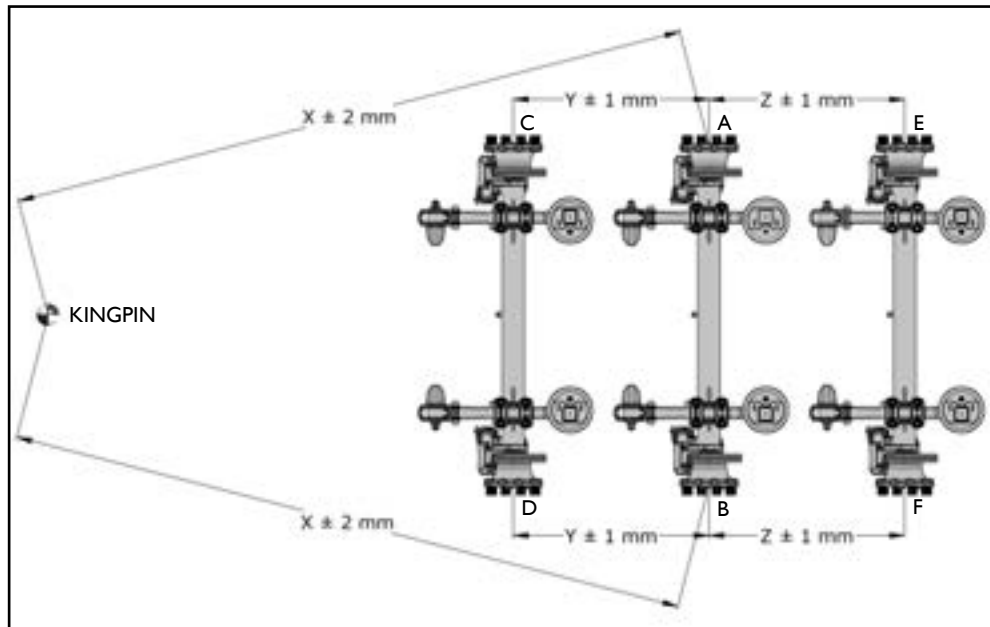

### 12.11 Pivot bolt connection

Apply grease on  $\frac{1}{4}$  of the thread surface.

Tighten the pivot bolt connection **at ride height** according instructions to torque.

*See tightening instructions: Section 10*

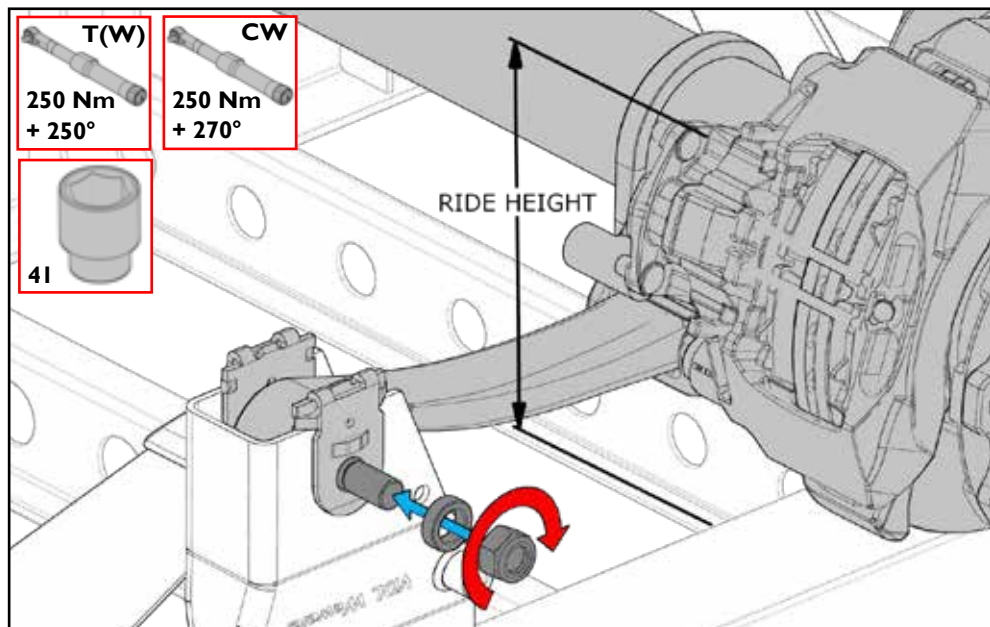



## 12. Chassis Mounting

### 12.12 Shock absorbers

Place the shock absorbers so that the code can be read. If present, follow the instructions on the shock absorber (see [Section 6](#)).

Tighten the top and bottom connection **at ride height** to torque according instructions.

*See tightening instructions: Section 10*

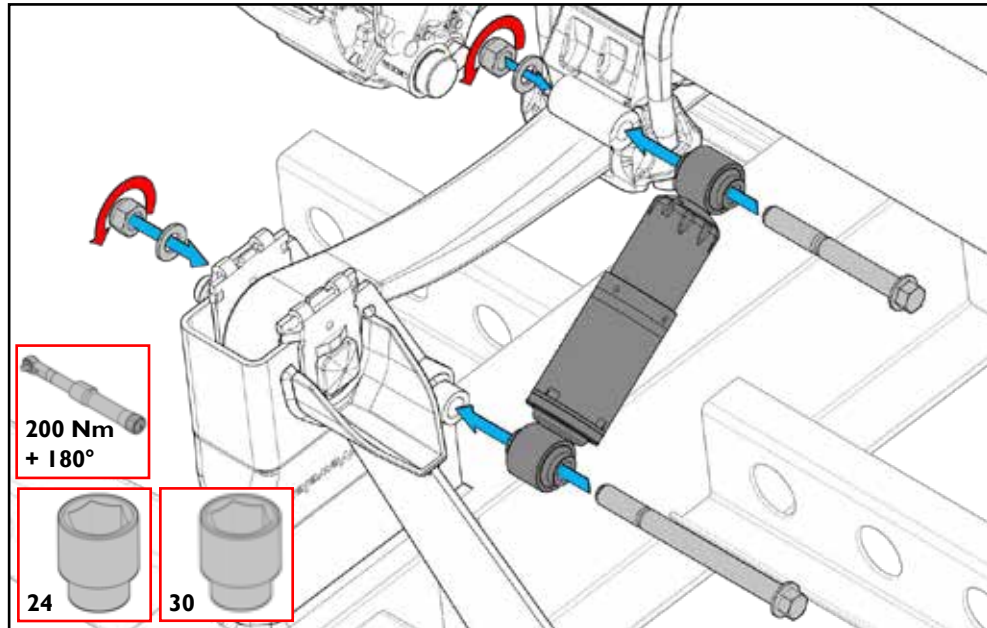

### 12.13 Air spring top

Place the locknuts and washers and tighten the air spring top connection according instructions on both sides of the vehicle.

*See tightening instructions: Section 10*

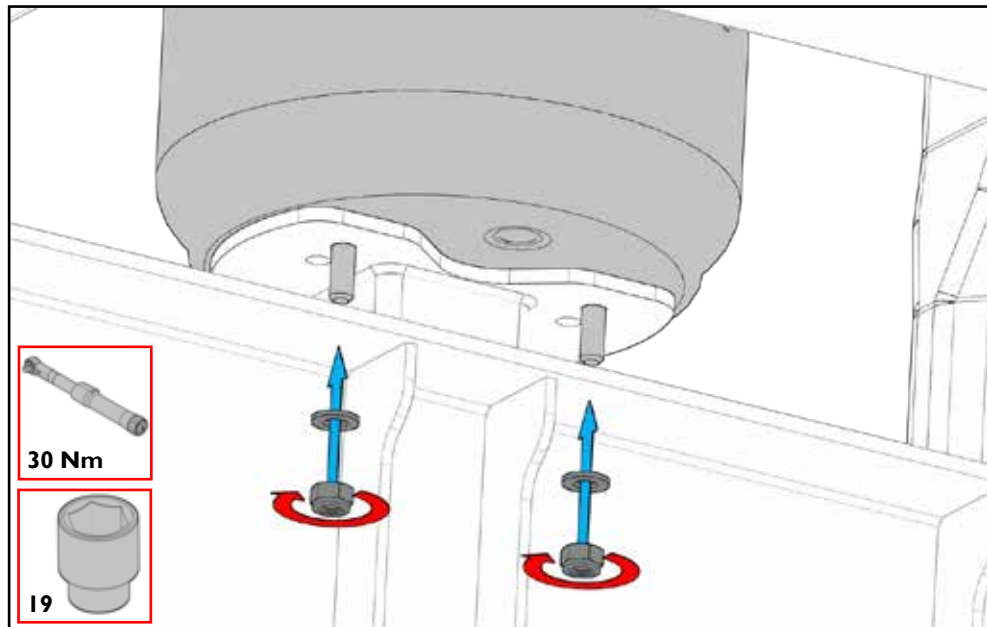

### 12.14 Axle lift

Place the axle lifts around the hanger brackets on both sides of the vehicle. Tighten per axle lift both bolts to torque according instructions.

*See tightening instructions: Section 10*

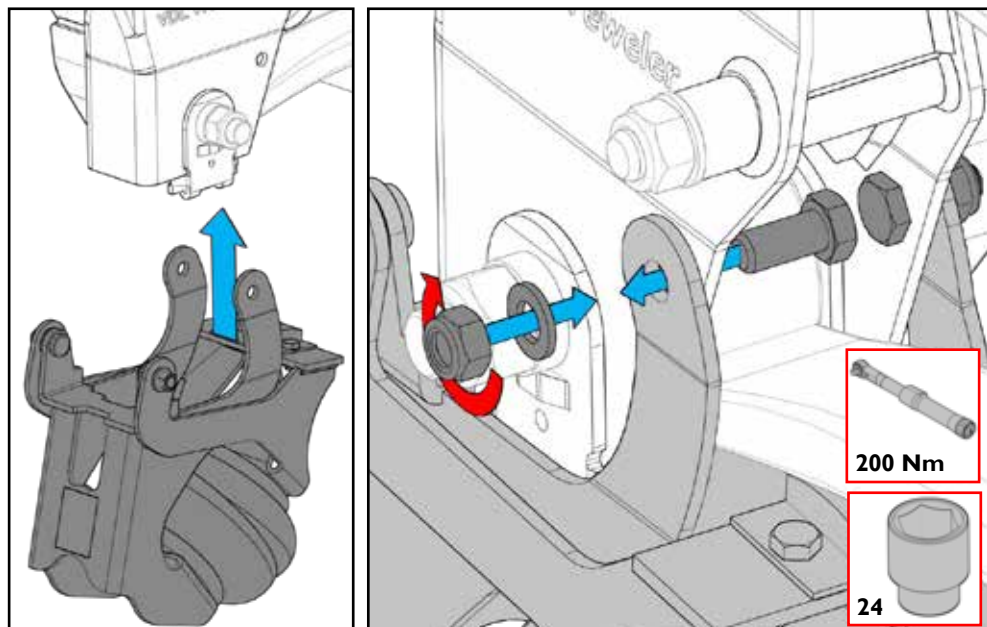

## 12. Chassis Mounting

### 12.15 Complete assembly

System assembly complete. Ready for wheel mounting.

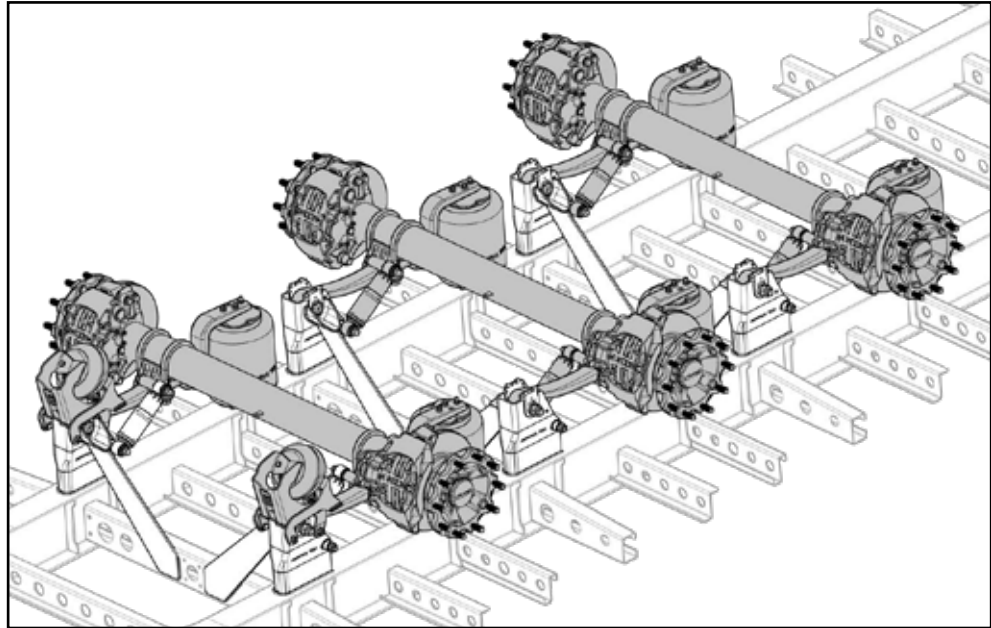

### 13. Available air spring options

#### 13.1 Mounting of standard air spring assembly

Depending on the type of air suspension several air springs are available with or without additional required support plates for the desired air spring offset. Check the supplied system or application drawing for the supplied type of air spring and required offset. Follow the corresponding instruction step(s) below. All shown air spring options show the lefthand side of the vehicle.

- Air spring Ø300	- Type 30K / 30MB	- Offset 20mm	<b>Step 13.2</b>
- Air spring Ø335	- Type 33K / 33MB	- Offset 45mm	<b>Step 13.3</b>
- Air spring Ø300 combo	- Type 30C / 30L	- Offset 0mm	<b>Step 13.4</b>
- Air spring Ø350 standard	- Type 36 / 36L	- Offset 50mm	<b>Step 13.5</b>
- Air spring Ø350 standard	- Type 36 / 36L	- Offset 90mm	<b>Step 13.6</b>
- Air spring Ø350 reinforced	- Type 36R / 36LR	- Offset 30 or 50mm	<b>Step 13.7</b>

#### 13.2a Air spring Ø300 Offset 20mm

First mount the air spring support plate correctly orientated for the Ø300 air springs on the 75 or 95 mm wide trailing arm with the countersunk M12 bolts and locknuts. Torque the M12 locknuts.

Next hand tighten the M12 stud in the air spring until it is fastened (at least 8 thread/wire runs). Then place the air spring support and the trailing arm. Torque the M12 locknut.

Make sure the upper air spring mounting studs and air inlet are in the correct position.

*See tightening instructions: Section 10*

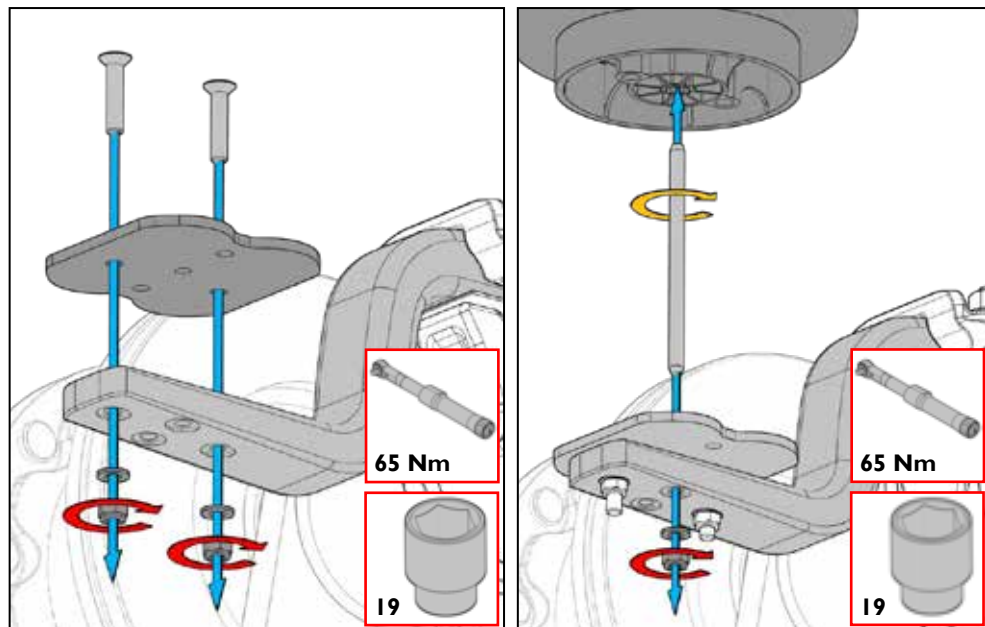

#### 13.2b Air spring to chassis / pedestal

Mount the Ø300 air spring top to the chassis or pedestal. Tighten the locknuts to torque according the instructions.

*See tightening instructions: Section 10*

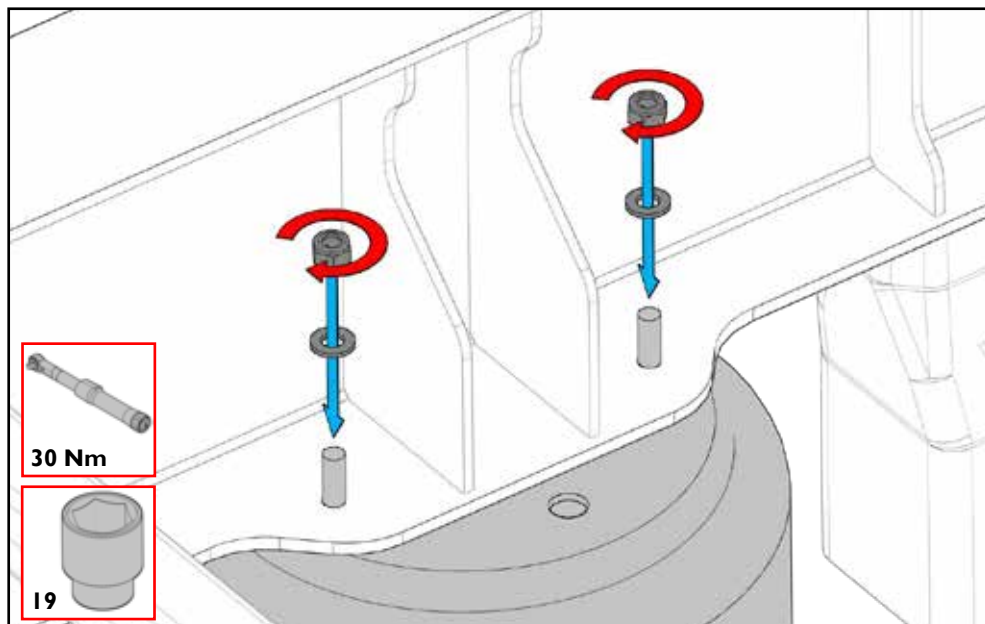

### 13. Available air spring options

#### 13.3a Air spring Ø335 Offset 45mm

First mount the Ø335 air spring on the Ø335 air spring support plate with the long countersunk M12 bolt. The two standard bolts are already welded to the support plate. Torque the countersunk bolt.

Next mount the air spring support with the Ø335 air spring on the 75 or 95 mm wide trailing arm with the M12 locknuts. Torque the locknuts.

Make sure the upper air spring mounting studs and air inlet are in the correct position.

*See tightening instructions: Section 10*

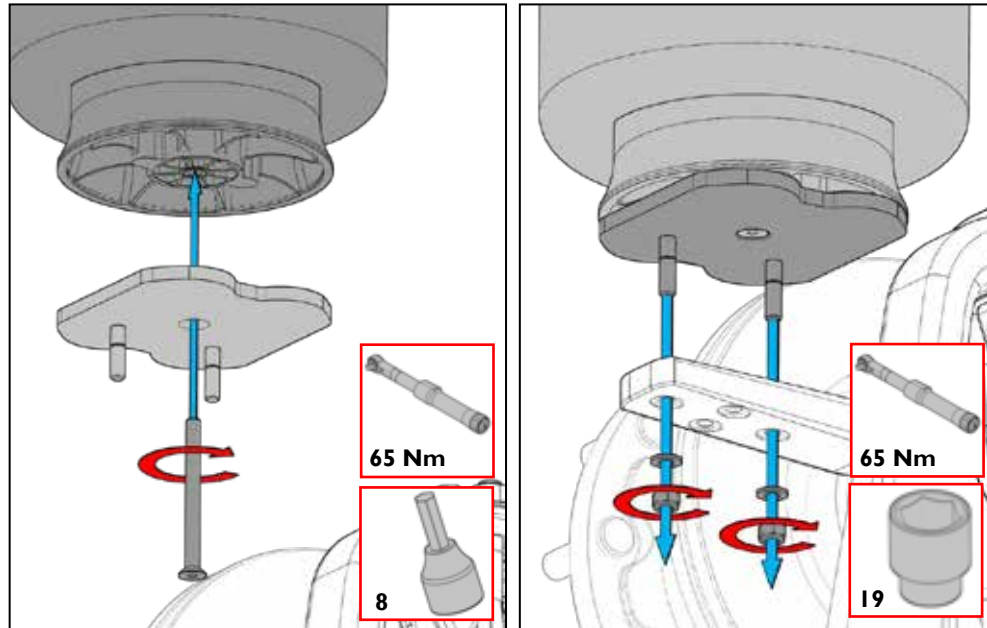

#### 13.3b Air spring to chassis / pedestal

Mount the Ø335 air spring top to the chassis or pedestal. Tighten the locknuts to torque according the instructions.

*See tightening instructions: Section 10*

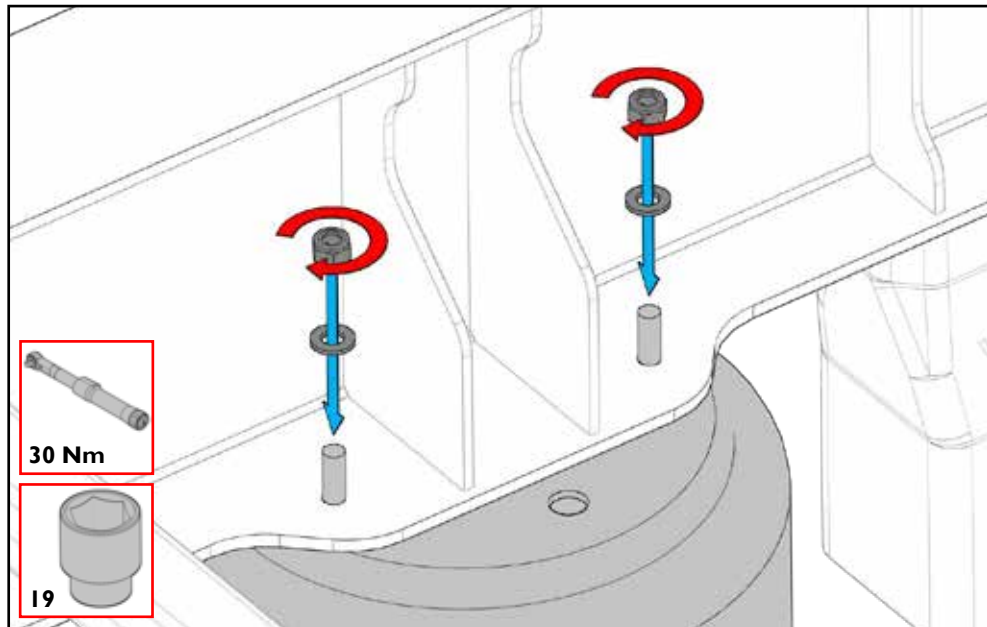

### 13. Available air spring options

#### 13.4a Air spring Ø300 combo Offset 0mm

For assembly including support plate, please follow step 13.4b.

Mount the Ø300 air spring with combo stud directly on the trailing arm with the M12 bolts. Tighten to torque according the instructions.

See tightening instructions: Section 10

Proceed to step 13.4c.

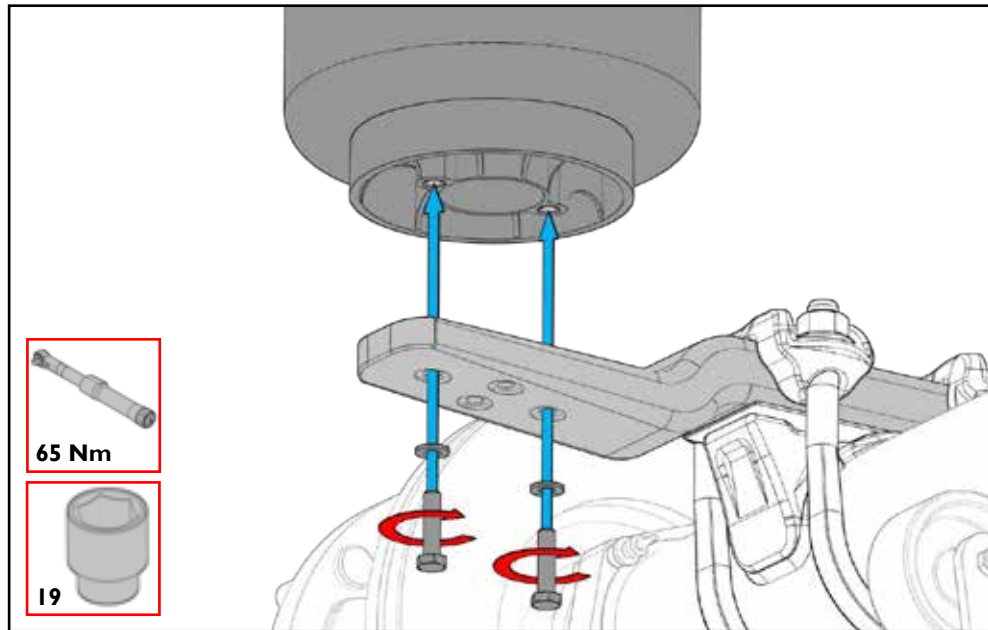

#### 13.4b Air spring Ø300 combo Offset 0mm + Support plate

Mount the Ø300 air spring with combo stud including the support plate correctly orientated as illustrated on the trailing arm with the M12 bolts. Tighten to torque according the instructions.

See tightening instructions: Section 10

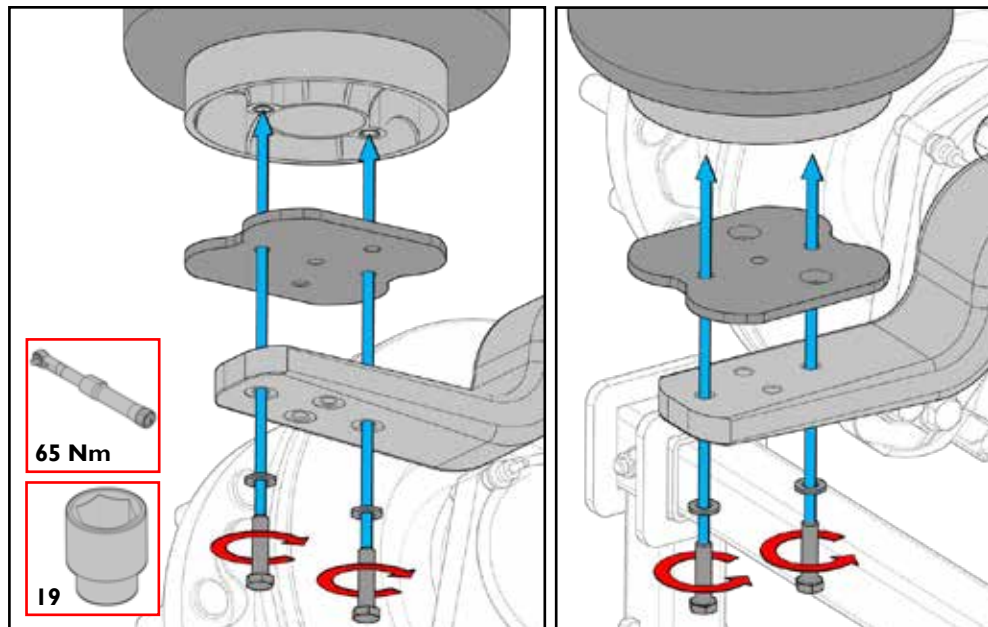

#### 13.4c Air spring to chassis / pedestal

Mount the Ø300 air spring top with combo stud to the chassis or pedestal. Tighten the (lock)nuts to torque according the instructions.

See tightening instructions: Section 10

In case the top connections require a different position/angle follow steps 13.4d through 13.4f.

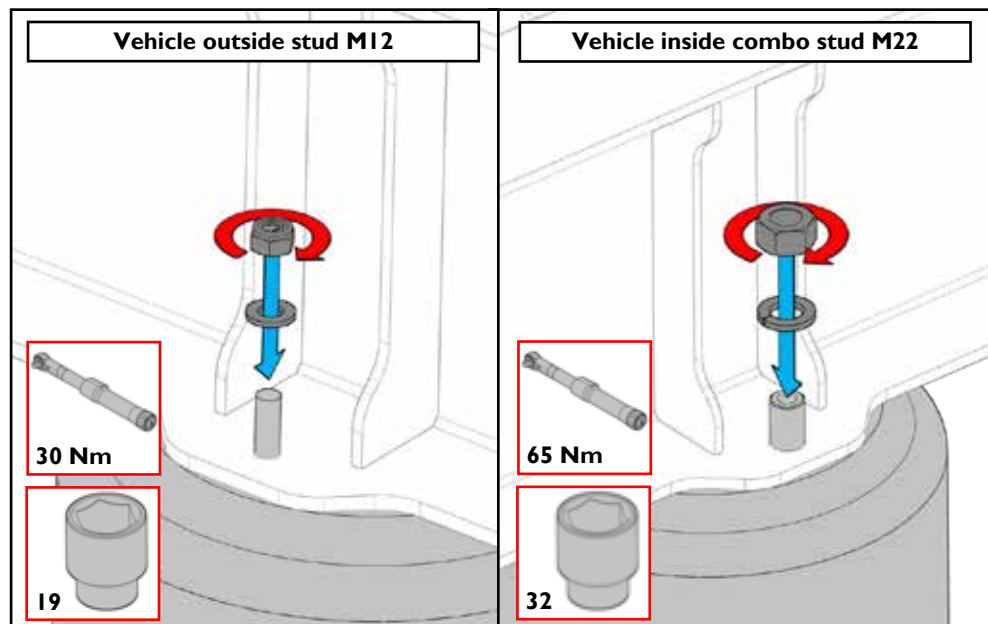

### 13. Available air spring options

#### 13.4d Rotating air spring Ø300 combo

Untighten the central bolt as much as possible to allow the flexmember to rotate.

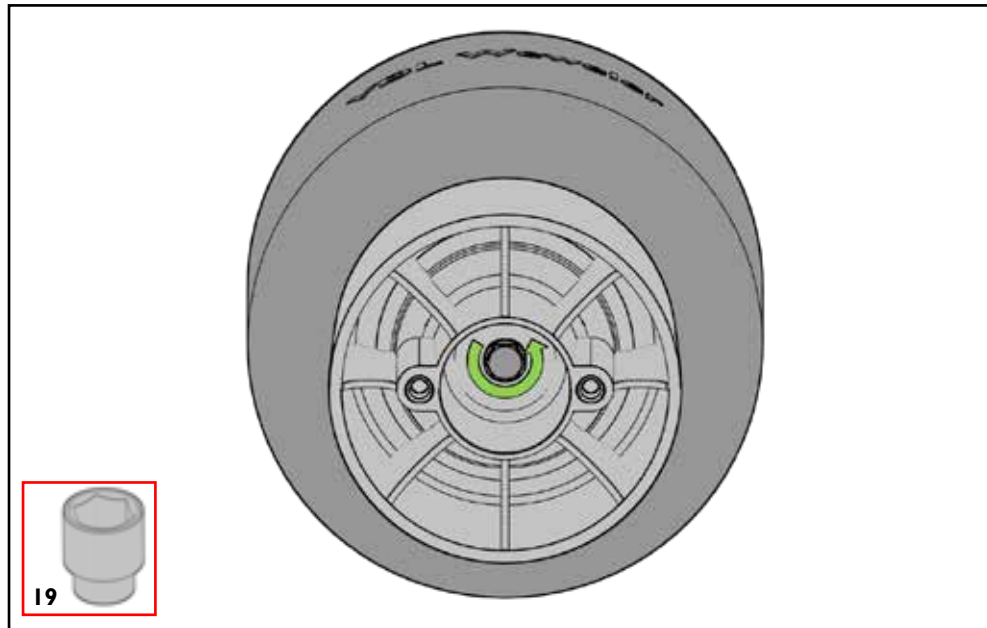

#### 13.4e Rotating air spring Ø300 combo

Rotate the flexmember to the desired position/angle.

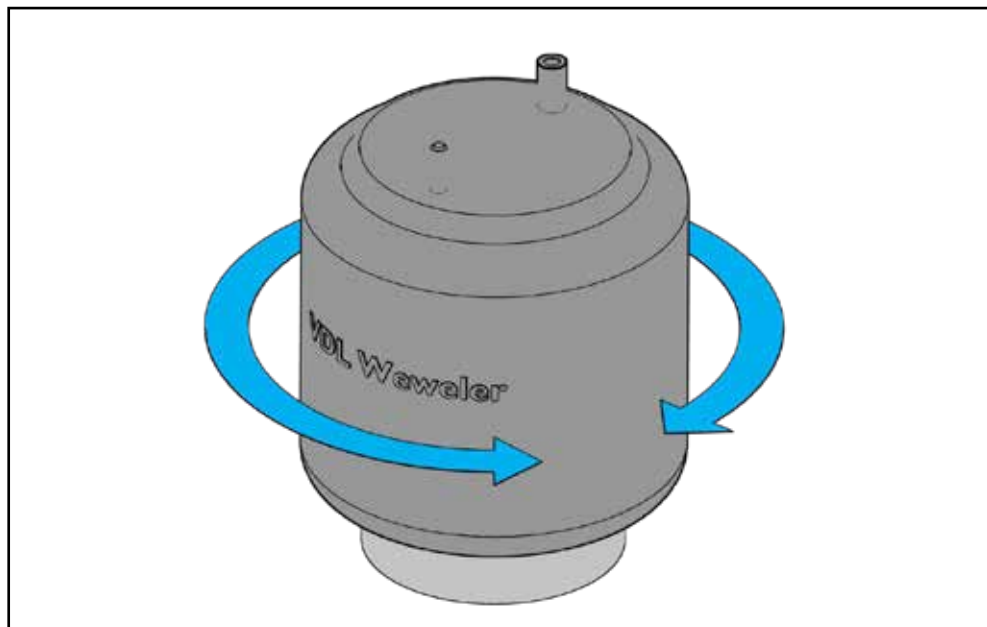

#### 13.4f Rotating air spring Ø300 combo

Re-assemble the air spring and tighten the central M12 bolt at **40 Nm**.

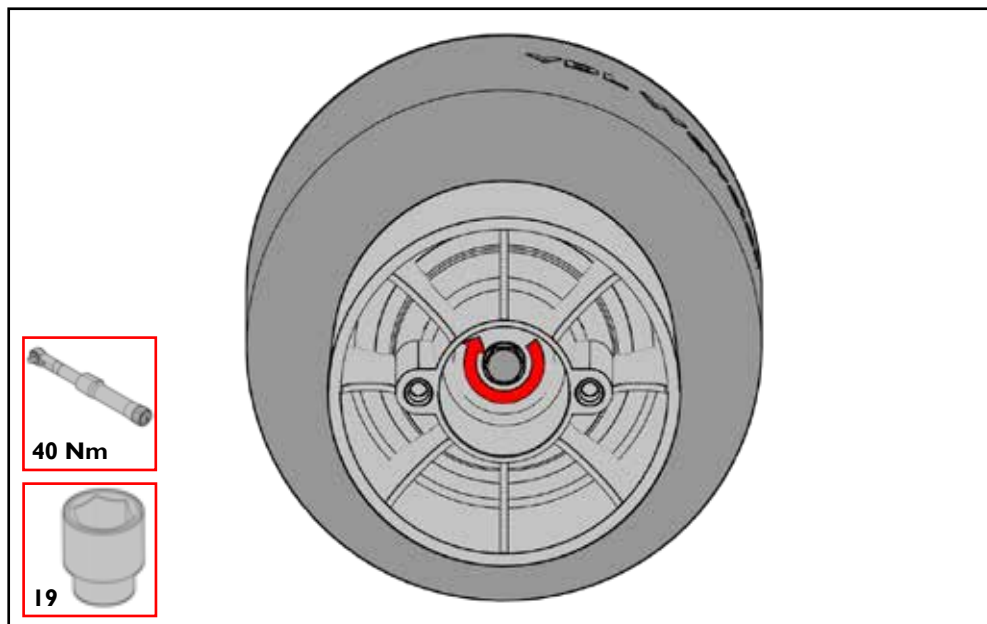

### 13. Available air spring options

#### 13.5a Air spring Ø350 Offset 50mm

Mount the Ø350 air spring including the bellow support plate on the 95mm wide trailing arm.

Tighten the bolts to torque according the instructions.

*See tightening instructions: Section 10*

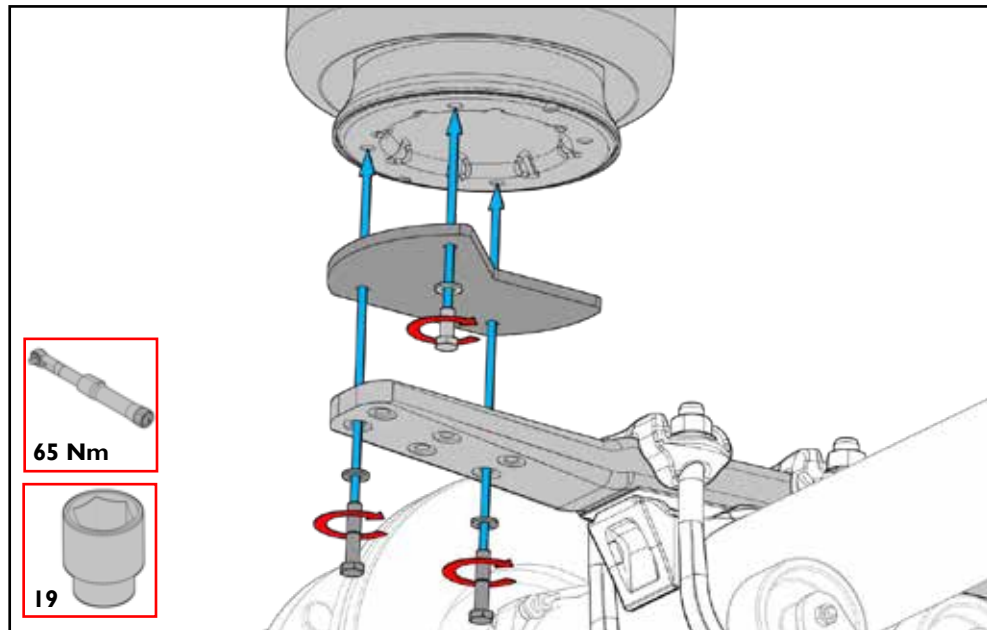

#### 13.5b Air spring to chassis / pedestal

Mount the Ø350 air spring top to the chassis or pedestal. Tighten the locknuts to torque according the instructions.

*See tightening instructions: Section 10*

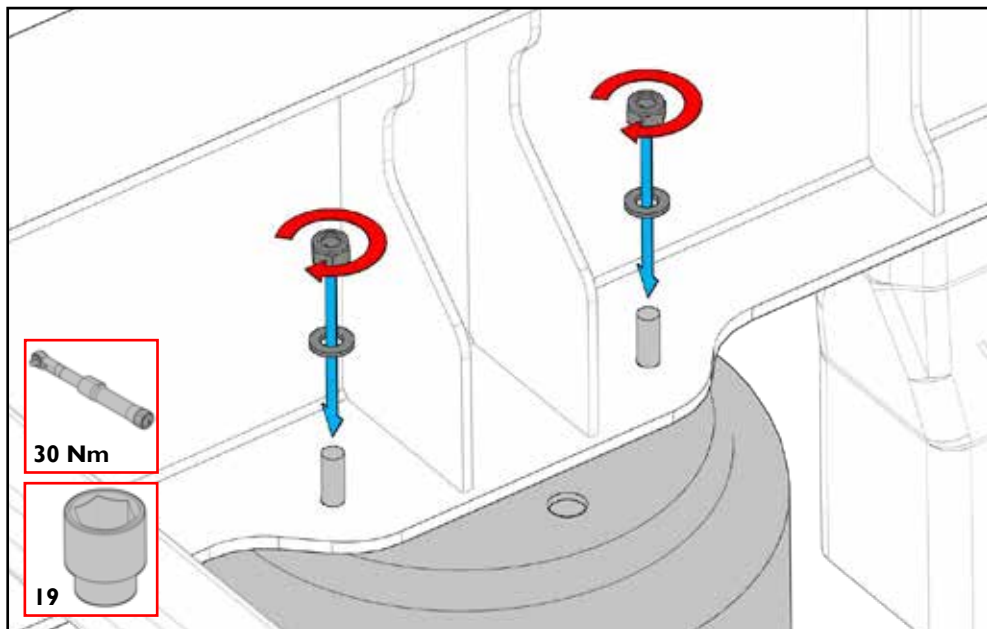

### 13. Available air spring options

#### 13.6a Air spring Ø350 Offset 90mm

First mount the air spring support plate on the trailing arm with the M12 countersunk bolts. Tighten the locknuts to torque according the instructions.

*See tightening instructions: Section 10*

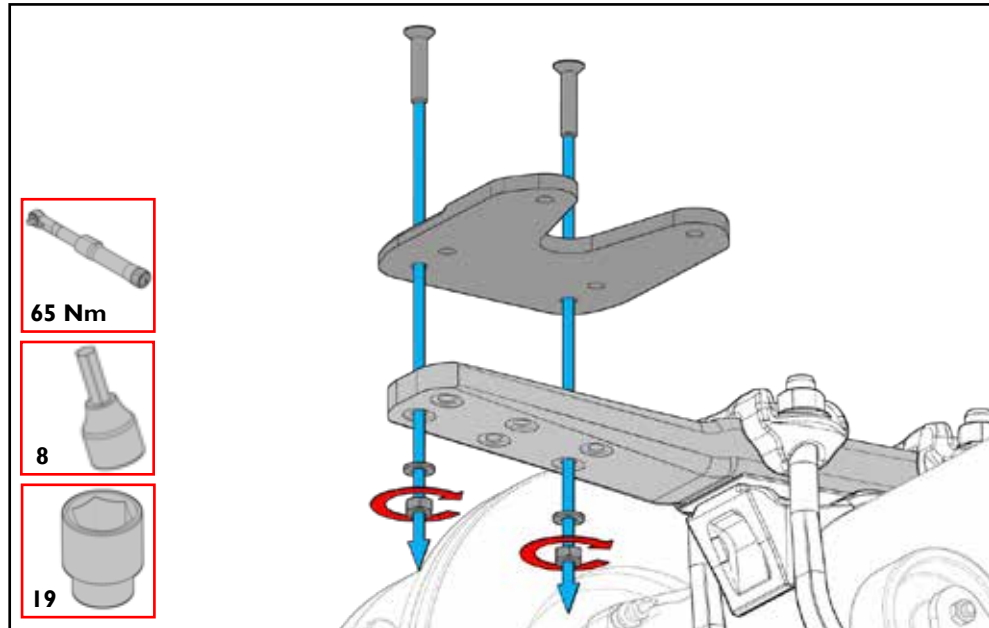

#### 13.6b Air spring Ø350 Offset 90mm

Next mount the Ø350 air spring to the support plate with the M12 bolts. Make sure the studs on top of the air spring are on the correct side. Tighten to torque according the instructions.

*See tightening instructions: Section 10*

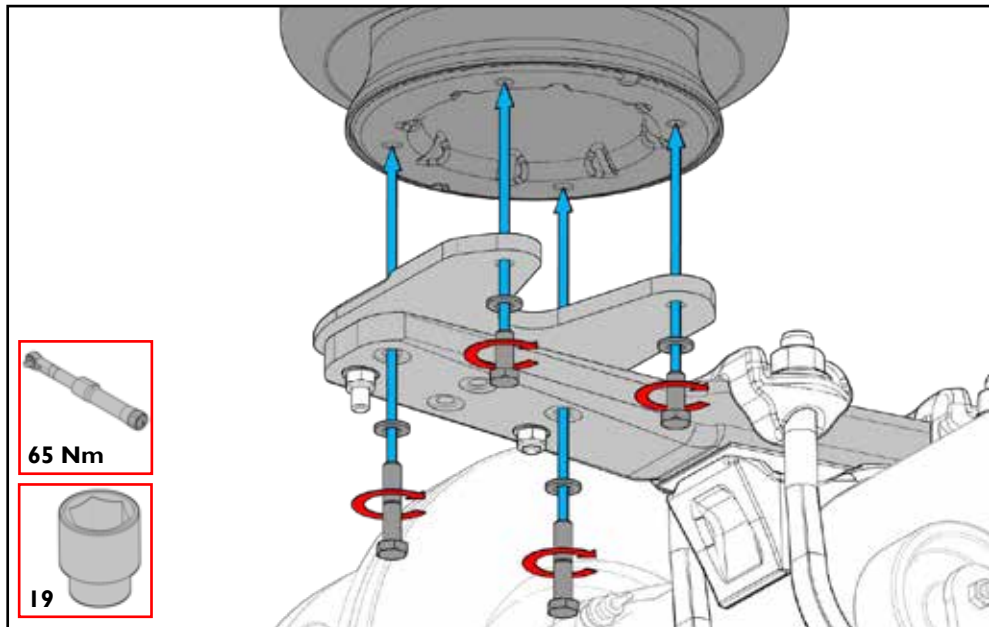

#### 13.4a Air spring to chassis / pedestal

Mount the Ø350 air spring top to the chassis or pedestal. Tighten the locknuts to torque according the instructions.

*See tightening instructions: Section 10*

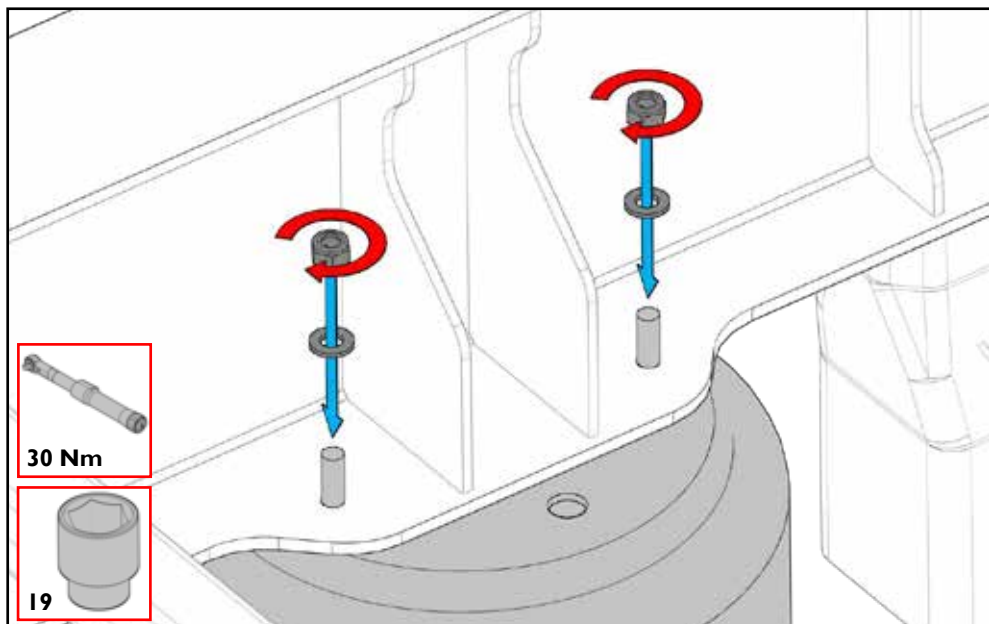



### 13. Available air spring options

#### 13.7a Air spring Ø350 - Reinforced 6-hole P serie Trailing arm Offset 50mm

Mount the Ø350 air spring with reinforced piston directly on the trailing arm with the M12 bolts. Tighten to torque according the instructions.

Make sure to use the correct holes in the piston. See the image on the far right.

See **step 14.7d** for the connection with the chassis or pedestal.

*See tightening instructions: Section 10*

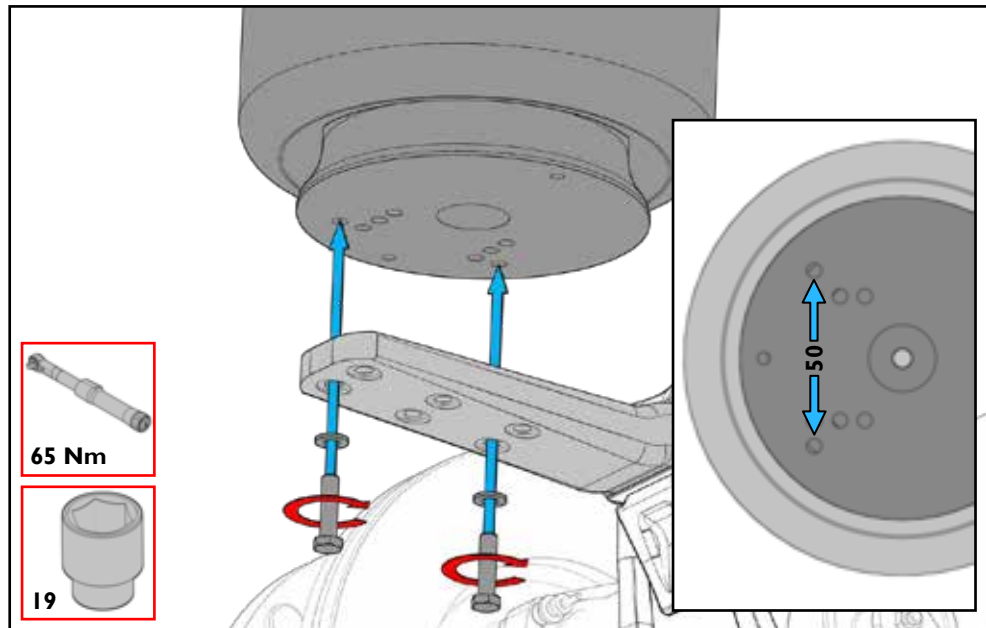

#### 13.7b Air spring Ø350 - Reinforced 4-hole P serie Trailing arm Offset 30mm

Mount the Ø350 air spring with reinforced piston directly on the trailing arm with the M12 bolts. Tighten to torque according the instructions.

Make sure to use the correct holes in the piston. See the image on the far right.

See **step 14.7d** for the connection with the chassis or pedestal.

*See tightening instructions: Section 10*

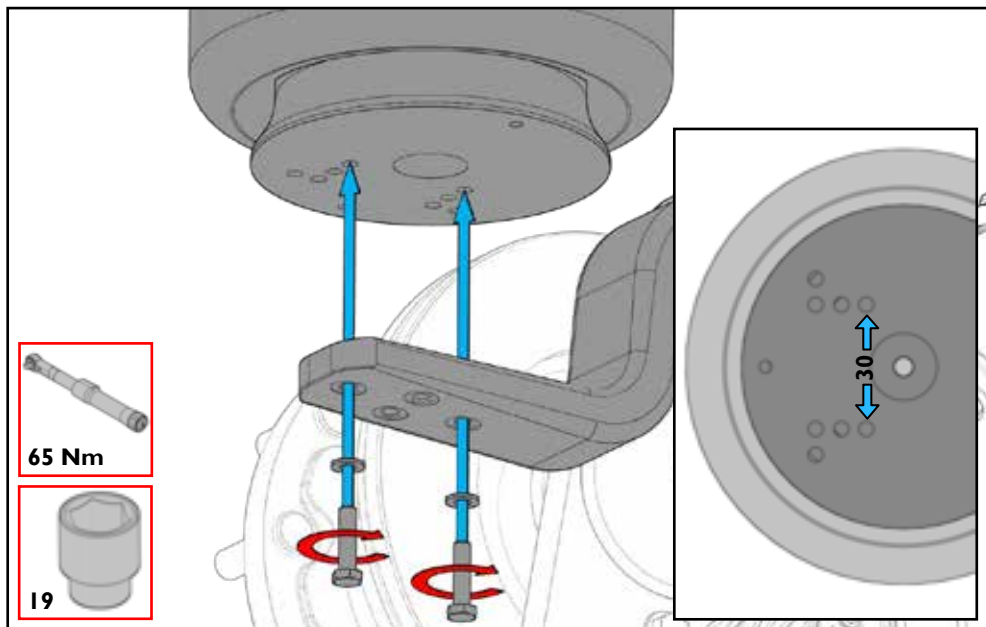

#### 13.7c Air spring Ø350 - Reinforced 4-hole P serie Trailing arm Offset 50mm

Mount the Ø350 air spring with reinforced piston directly on the trailing arm with the M12 bolts. Tighten to torque according the instructions.

Make sure to use the correct holes in the piston. See the image on the far right.

See **step 14.7d** for the connection with the chassis or pedestal.

*See tightening instructions: Section 10*

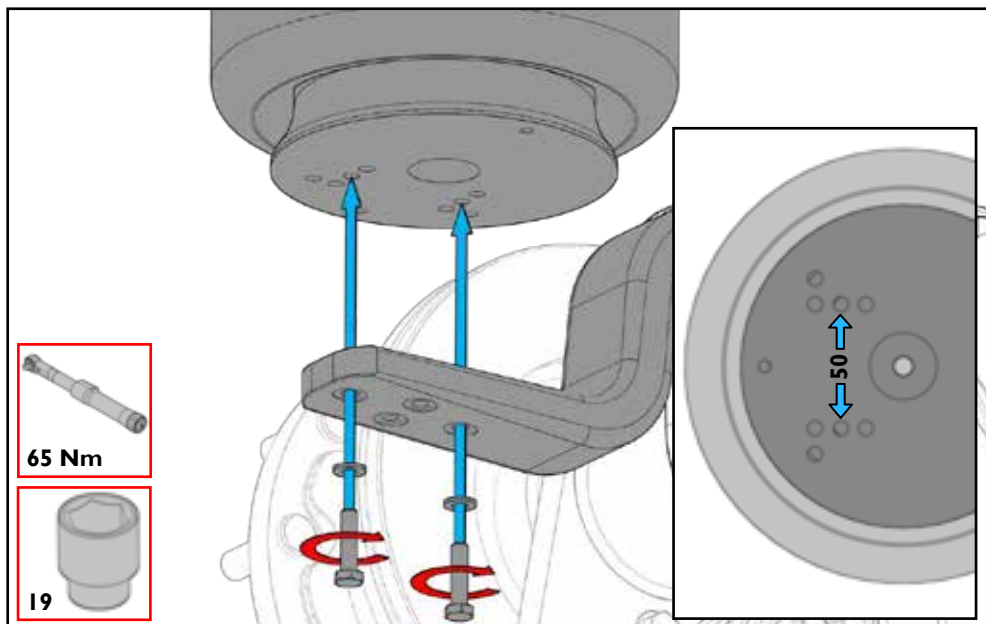

### 13. Available air spring options

#### 13.7d Air spring to chassis / pedestal

Mount the Ø350 air spring top to the chassis or pedestal. Tighten the locknuts to torque according the instructions.

See tightening instructions: *Section 10*

