



# FUWA K HITCH (Australia) Pty Ltd

ABN 54 078 731 209

**Head Office  
Melbourne**  
13-21 Bliss Court  
Derrimut VIC 3026  
Tel. 03 9369 0000  
Fax. 03 9369 0100

**Queensland**  
41 Moreton  
Heathwood Qld 4110  
Tel. 07 3372 2223  
Fax. 07 3372 1022

**Perth**  
5 Freight Road  
Kenwick WA 6107  
Tel. 08 9350 6470  
Fax. 08 9350 6570

## SALES SPEC SHEET

# 5<sup>TH</sup> WHEEL **KS16F**

The FUWA K Hitch **KS16F** 5<sup>th</sup>Wheel is fully fabricated from high grade quality steel.

Featuring a 90mm 2-jaw design, heavy duty feet (bronze bushes), 70mm foot pins, extra wide top plate and a one-point greasing system.

This HD 5<sup>th</sup> wheel is designed and made for mining applications!

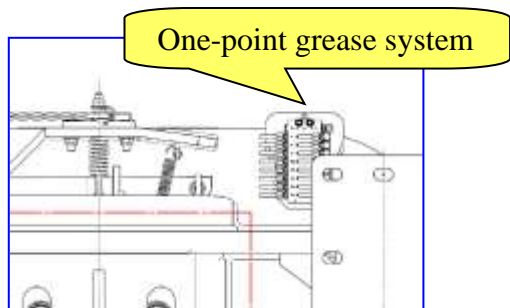
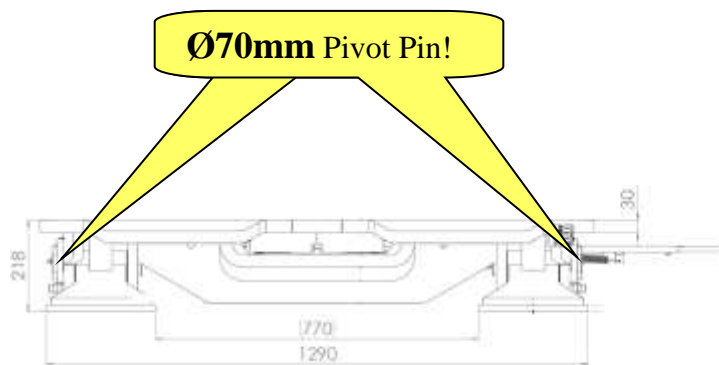
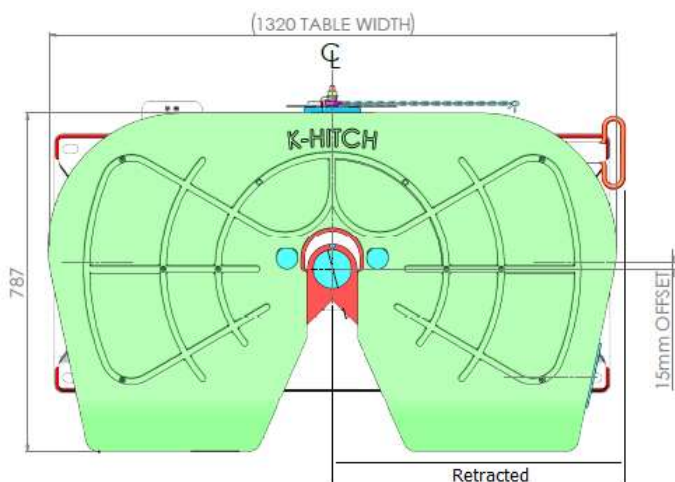

Model Number	Model Name	Top Lube	Top Width
KS16F90	KOMODO75	Grease-able	1320mm
Handle Length	Guide only	Retracted 680mm	Extended 765mm

Mount Height (mm)	King Pin Size (mm)	Vertical Load (kg)	D-Rating (kN)	Weight (kg – c/w Feet)
218	90	75,000	450	512



# FUWA K HITCH (Australia) Pty Ltd

ABN 54 078 731 209

**Head Office  
Melbourne**  
13-21 Bliss Court  
Derrimut VIC 3026  
Tel. 03 9369 0000  
Fax. 03 9369 0100

**Queensland**  
41 Moreton  
Heathwood Qld 4110  
Tel. 07 3372 2223  
Fax. 07 3372 1022

**Perth**  
5 Freight Road  
Kenwick WA 6107  
Tel. 08 9350 6470  
Fax. 08 9350 6570

## KS SERVICE INFORMATION

<b>BULLETIN NUMBER</b>	<b>TOPIC</b>	<b>DESCRIPTION</b>
KPW-002-0110	Warranty	Limitation of Liabilities
KPW-004-0110		LGL's
KPM-001-0110		Claim Form
FKH Engineering	Installation	Drawings as required
KPS-002-0818	Parts	Parts View
KPM-001-0617	Maintenance	Installation & Service Bulletin

[www.khitch.com.au](http://www.khitch.com.au)

