

Fuwa



KHITCH

Part No.  
N100526-001

**FUWA** K-Hitch Australia Pty Ltd

[www.khitch.com.au](http://www.khitch.com.au)

+61 (03) 9369-0000

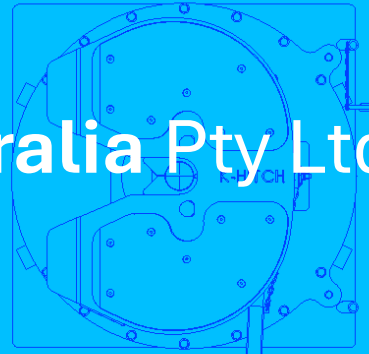

# INSTALLATION BULLETIN

**Bulletin ID :** FKH-INSTL-0005

**Issued Date :** 21 October 2024

**Revision :** Rev A

**Reference Documents :** KPM-008-0410 Rev 10

## S-CAM DIRECTION OF ROTATION RECOMMENDATION



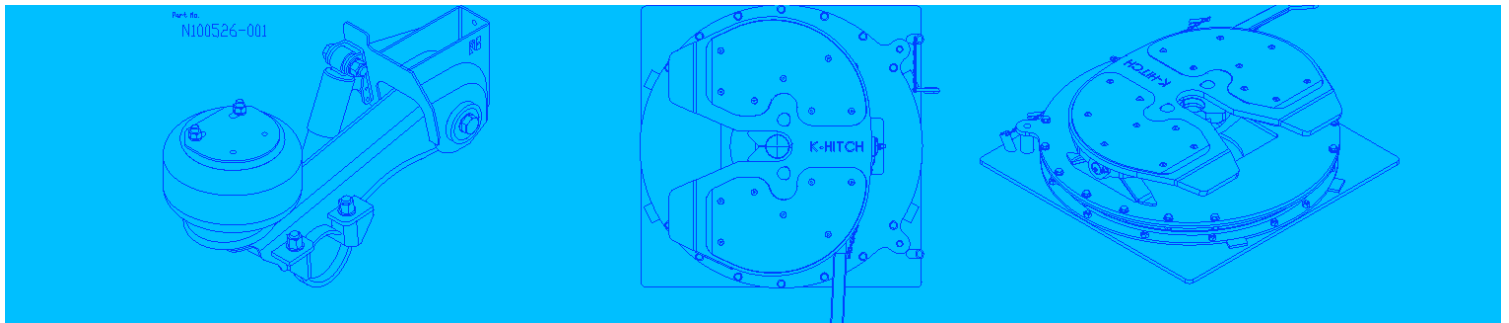

## SCOPE

This recommendation covers all drum brake configurations supplied by Fuwa K-Hitch.

## INSTALLATION RECOMMENDATIONS

Fuwa K-Hitch Australia recommends (*it is also a general industry recommendation*) to install Drum Brake Axles so that the S-Cam direction of rotation when the brakes are applied, is in the same direction of rotation to the brake drum and tire assembly, when travelling in the forward direction, as illustrated below.

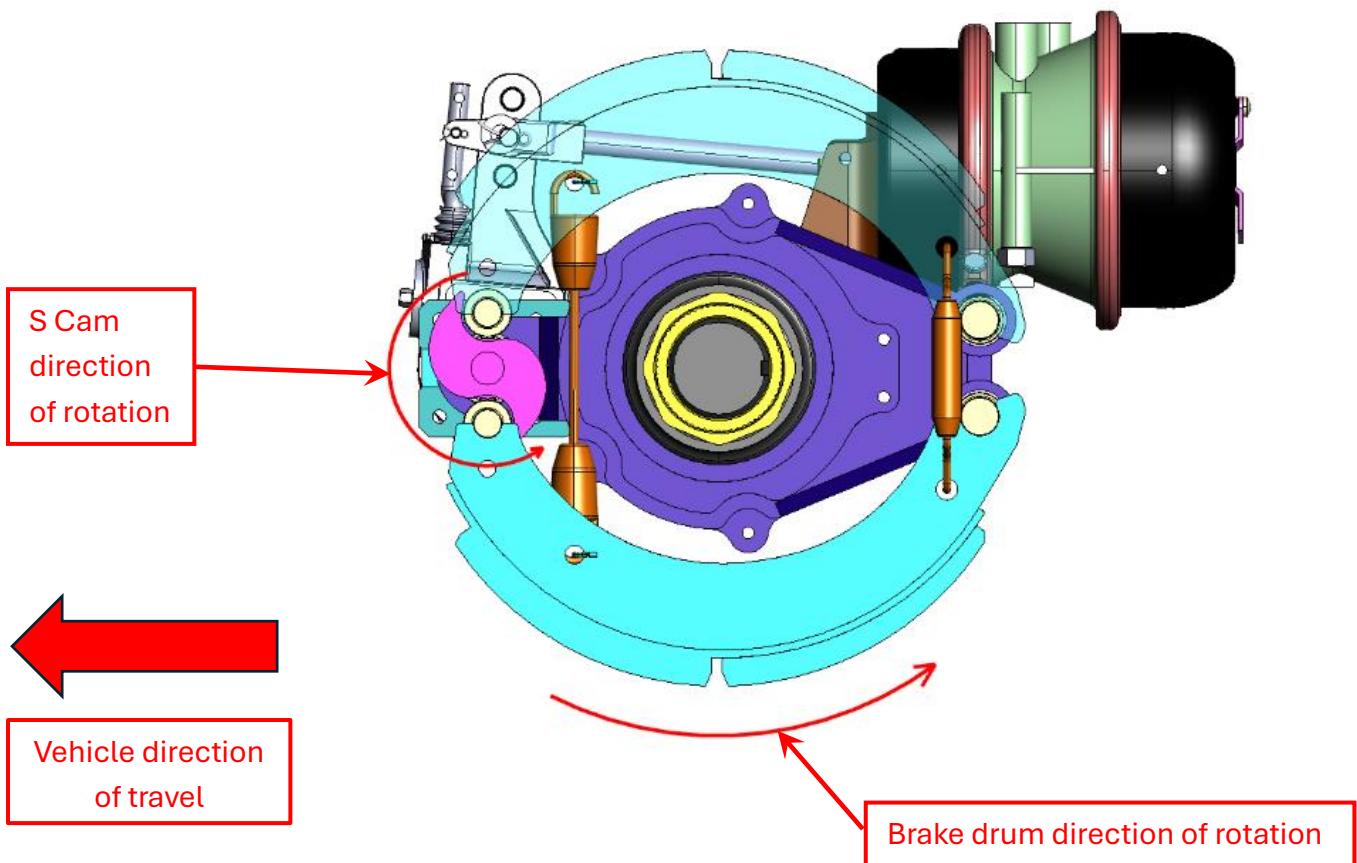

Failure to comply with this recommendation by having the S-Cam rotating against the direction of the wheels when travelling forward (*reversed S-Cams*) may result in noisy brakes, premature wear of the brake linings and premature wear of the tires.

Installers can rotate the axle to position the camshafts and boosters away from obstructions such as the trailer frame or suspension components, provided the S-Cam rotational direction is not affected and complies with the recommendation in this bulletin.