



Part No.  
N100526-001

**FUWA** K-Hitch Australia Pty Ltd

[www.khitch.com.au](http://www.khitch.com.au)

+61 (03) 9369-0000

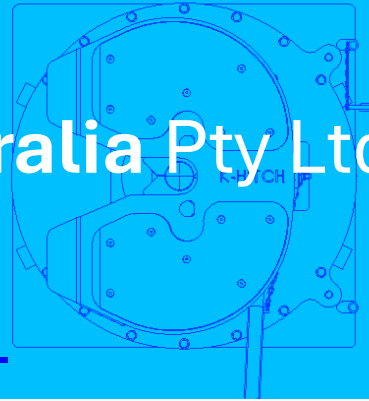

# INSTALLATION BULLETIN

**Bulletin ID :** FKH-INSTL-0009

**Issued Date :** 22 October 2024

**Revision :** Rev A

**Reference Documents :** KPM-001-0312 Rev 10

## INSTALLING ASH AUTOMATIC SLACK ADJUSTERS

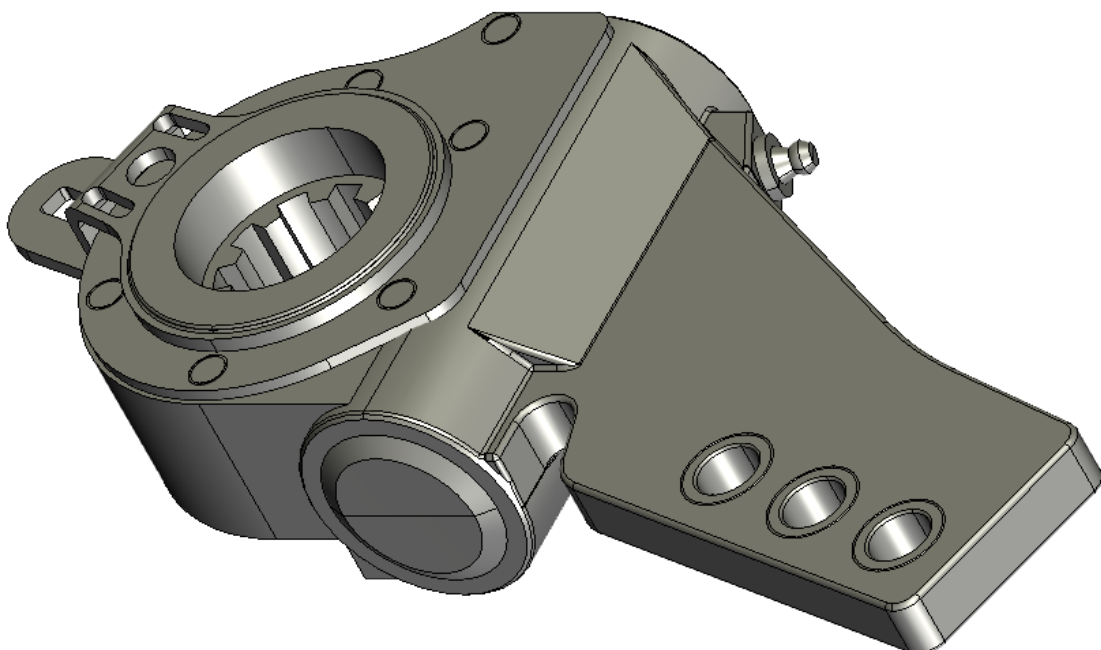

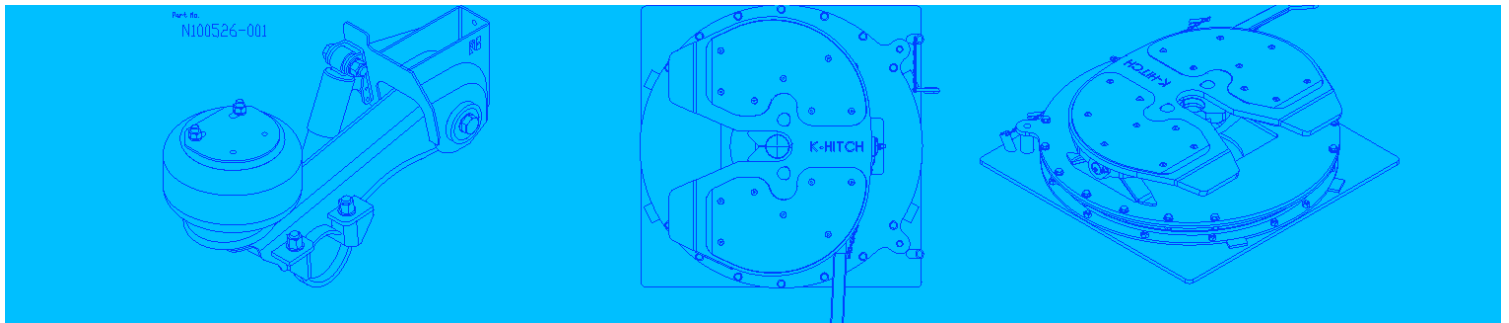

## SCOPE

This document covers the fitment of ASH automatic slack adjusters (ASA) on drum brake systems. (*Haldex type*)

## INSTALLATION RECOMMENDATIONS

Install the brake chamber onto the axle following the installation recommendations then follow the instructions in this document.

The brake system is a safety critical component of the vehicle combination and needs to be specified and installed according to the legal requirements and manufacturers recommendations.

### Precautions

Below are a few safety points to consider when installing brake boosters, a company specific safe work practices and risk assessment study should be conducted and followed.

1. Follow company procedures.
2. Wear Personal Protective Equipment (PPE) as directed.
3. The brake chamber contains a spring under pressure do not disassemble.
4. Follow build documentation, ask for support if unsure.
5. Use the correct equipment for the job.
6. Always chock the wheels when working on the brakes.
7. Be careful of pinch points on your hands.

### Preparation

The correctly sized brake chamber should be installed onto the axle assembly in the specified location. If this brake chamber is a spring brake chamber the chamber should be caged until after the slack adjuster is correctly adjusted.

Ensure that all of the correct parts have been supplied and the brake chamber position on the slack adjuster is as specified per the brake calculation.

Ensure that the brake chamber pushrod length is correct.

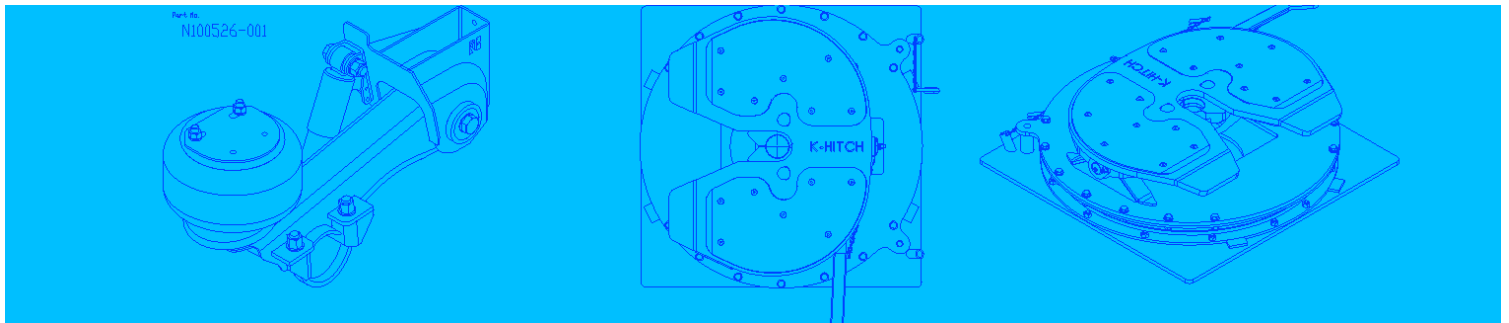

## Assembly

Remove the circlips, outside slack adjuster washers and red plastic protection sleeves from the S-Cam shaft, parts illustrated shown below.

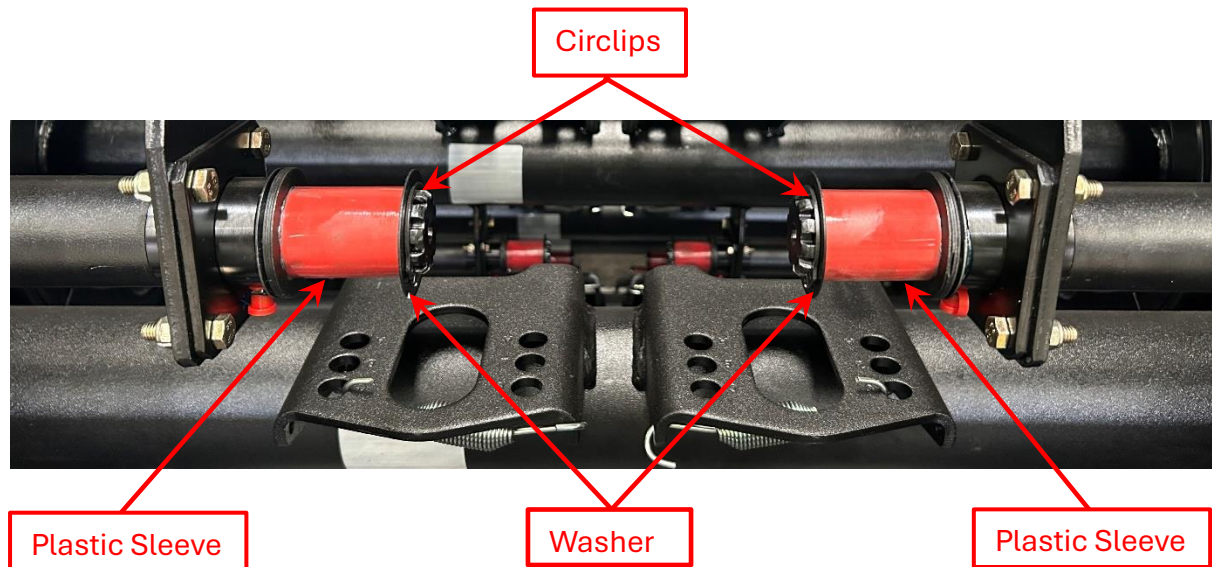

Ensure that the S-Cam spline is clean and has some lubrication on it, the anti-rust protection on a new axle assembly is acceptable. *(Castrol Ultratak (NLGI 2) or equivalent is recommended for additional lubrication)*

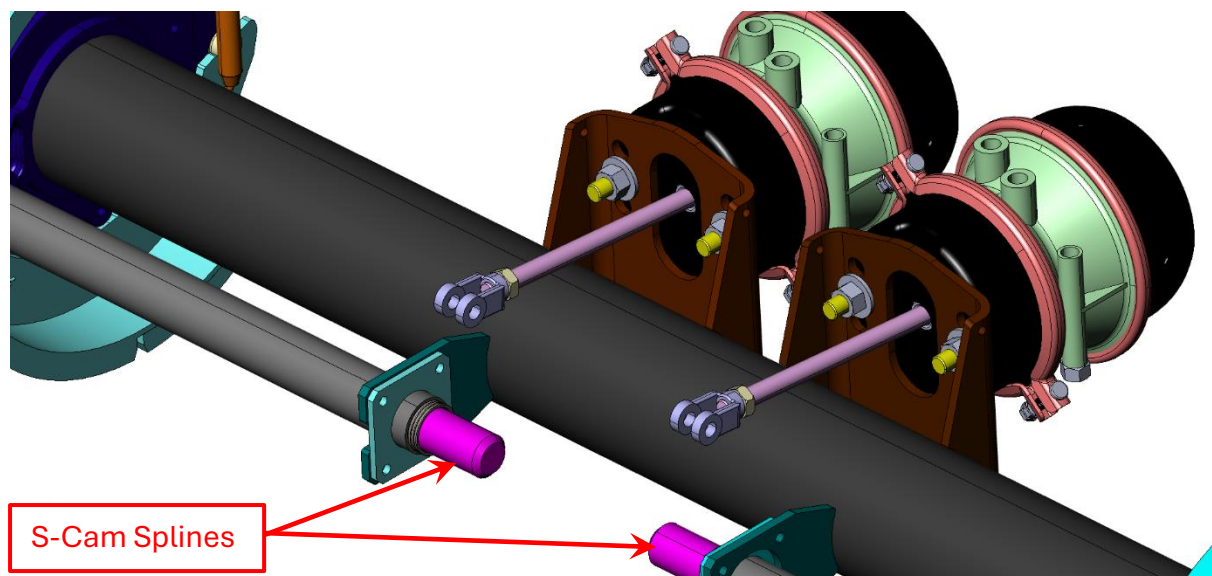

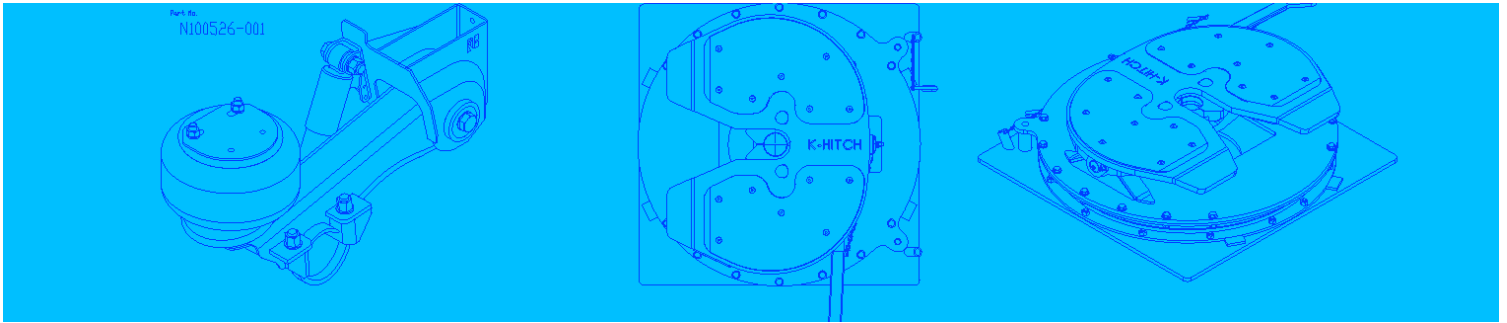

If the slack adjuster anchor bracket is not already fitted, fit the anchor bracket to the lower 2 bolts of the S-Cam tube bracket, on the spline side of the S-Cam tube bracket and then retorque the fasteners to 25Nm (18.5 ft-lbs.) as shown below.

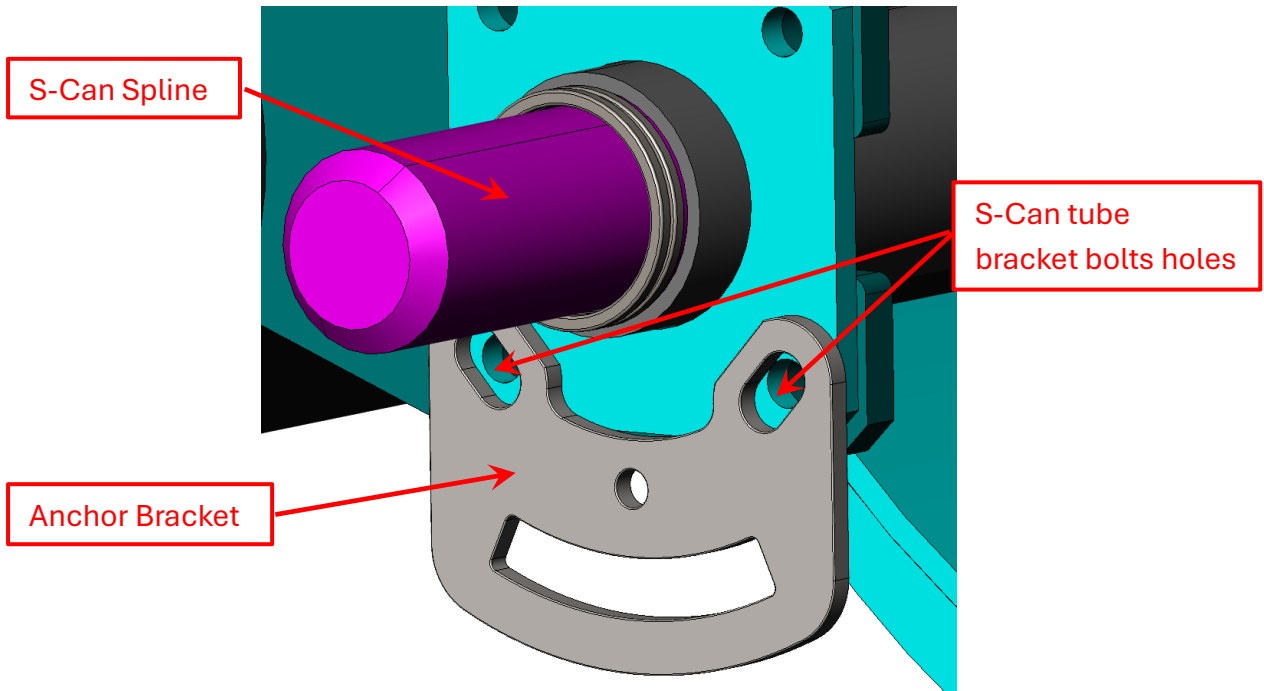

Install the ASH automatic slack adjuster onto the S-Cam spline. Make sure to select a spline that will allow the slack adjuster to pass the brake chamber clevis. Try to evenly space the slack adjuster washer either side of the slack adjuster.

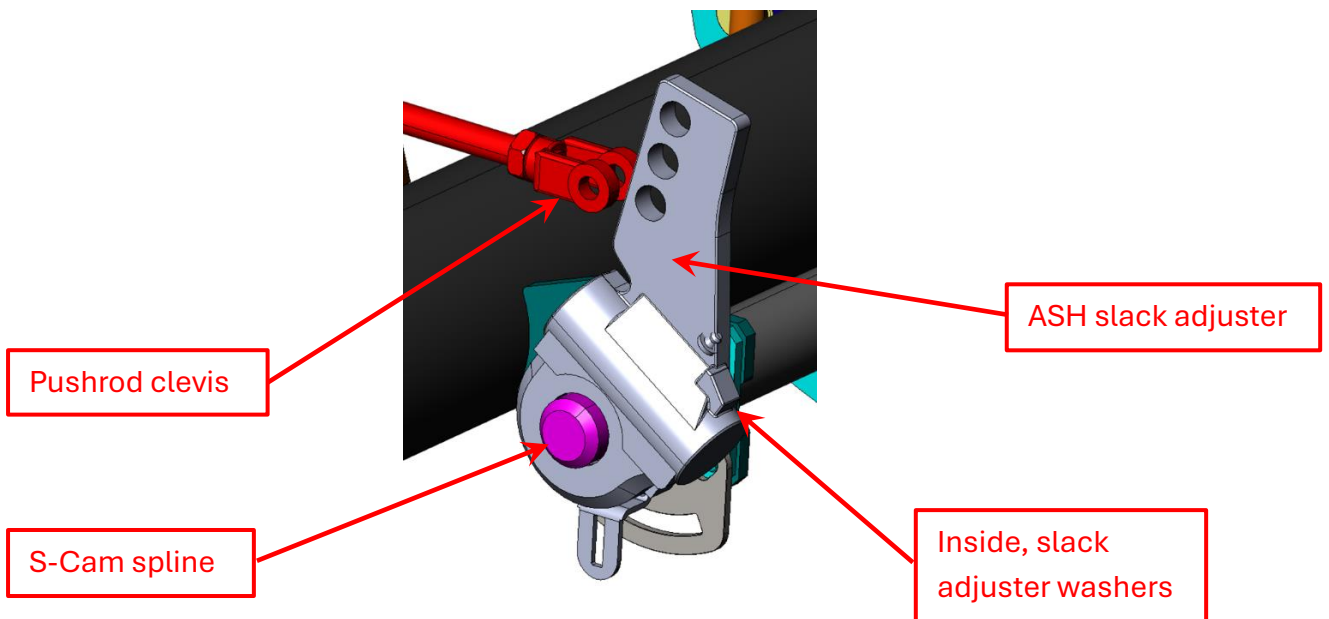

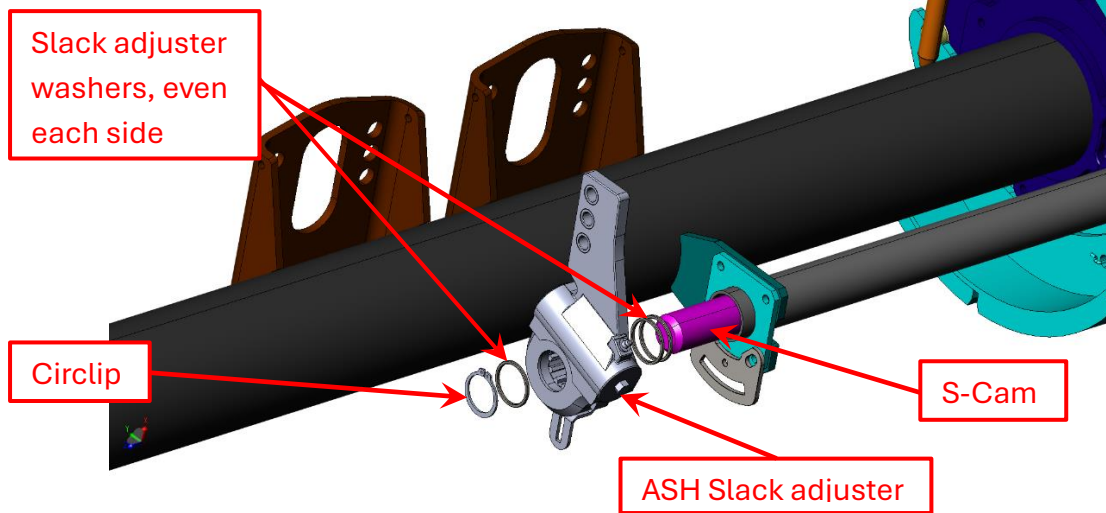
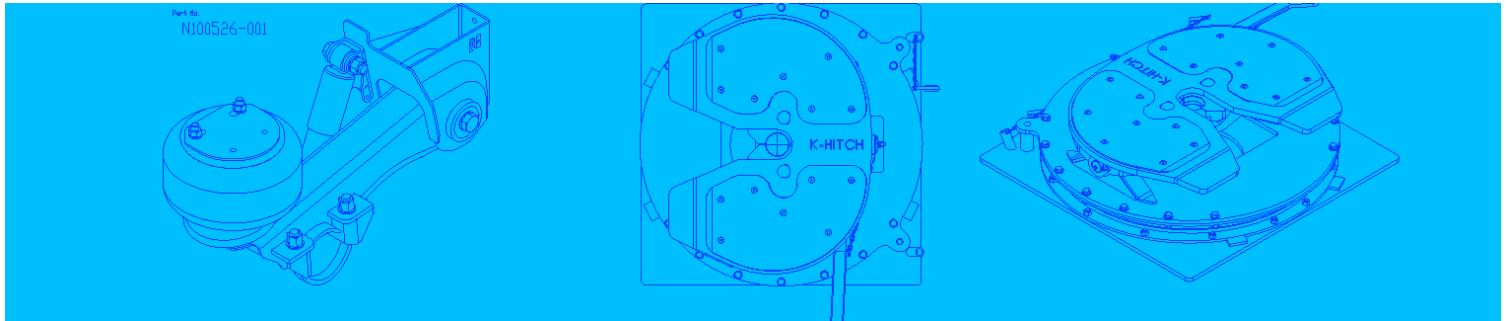

With a 12mm ring spanner (*Do NOT use an impact gun*) rotate the manual adjuster screw clockwise, until the clevis and the specified slack adjuster hole position line up as shown below. *Note: do not pull the slack adjuster backwards, if the slack adjuster moves to far forward, turn the adjustment screw anticlockwise and start again.*

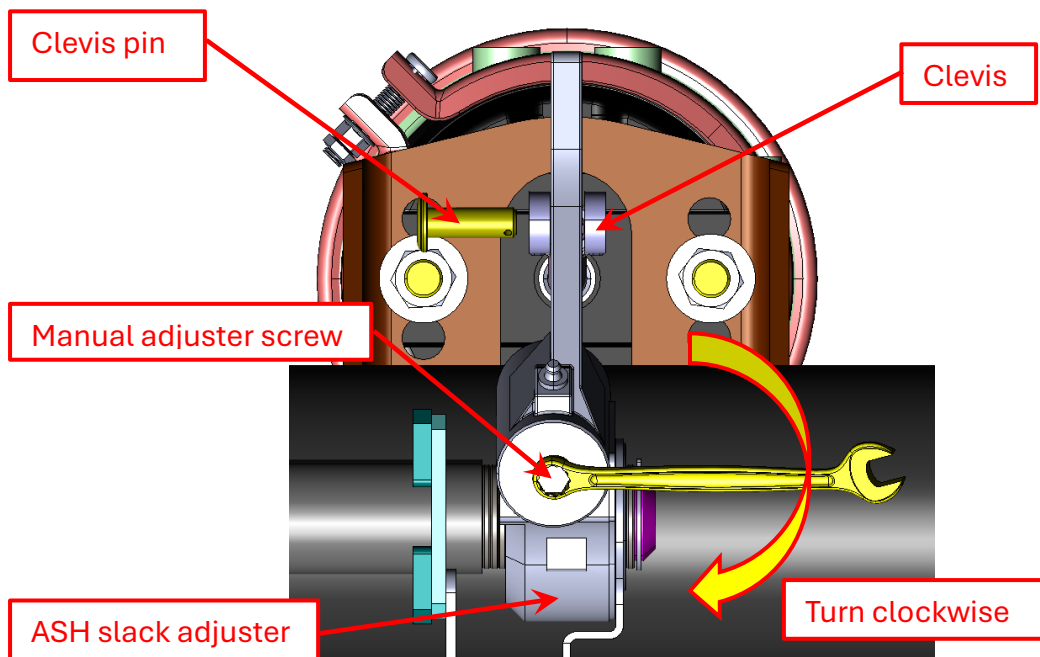

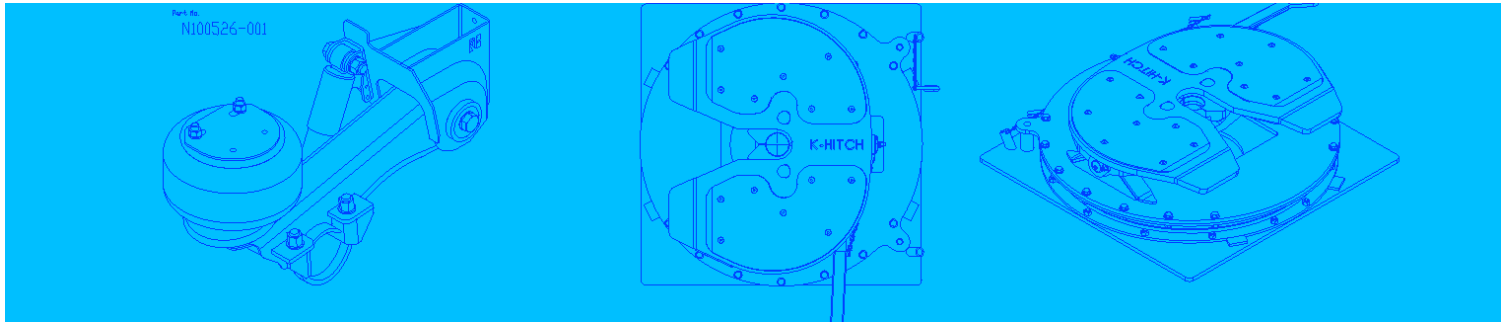

The slack adjuster hole positions are the same as the brake chamber mounting bracket positions 127 mm (5", A-A), 152 mm (6", B-B) and 178 mm (7", C-C).

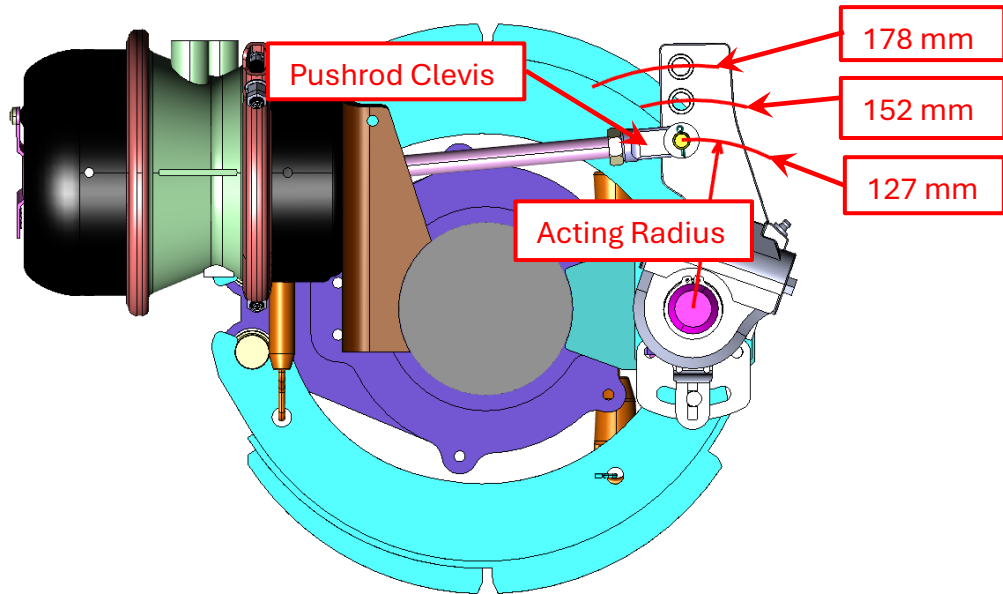

Then insert the clevis pin through the clevis and the slack adjuster by hand. Insert the split pin and deform it securing the clevis pin.

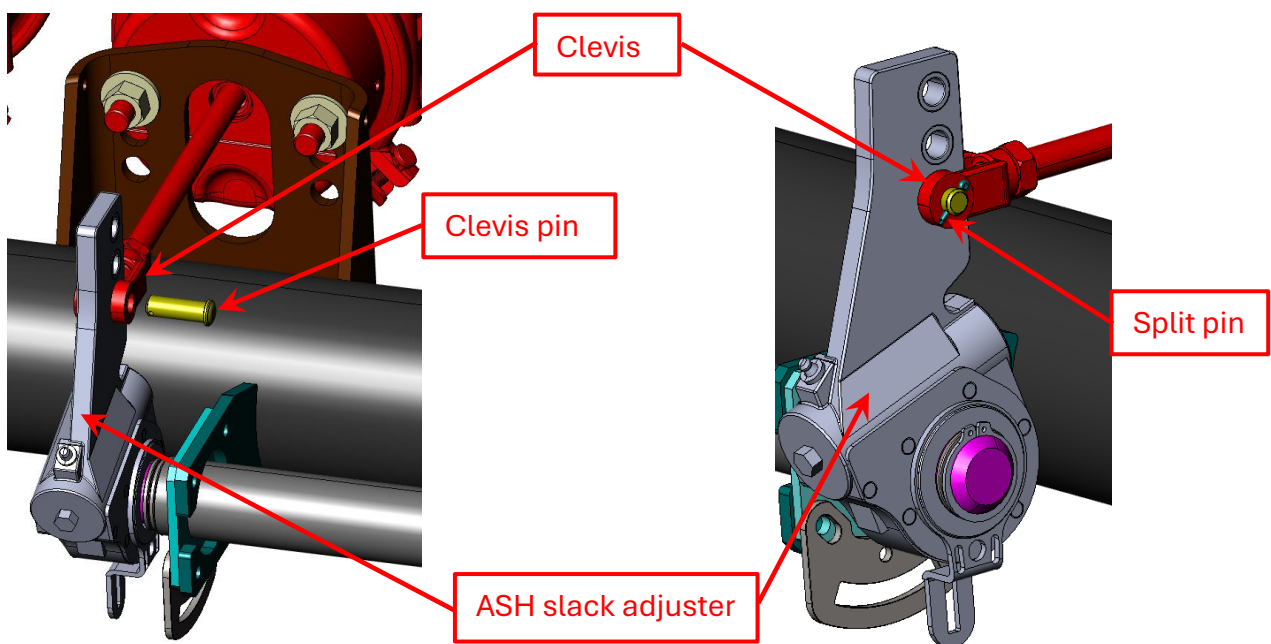

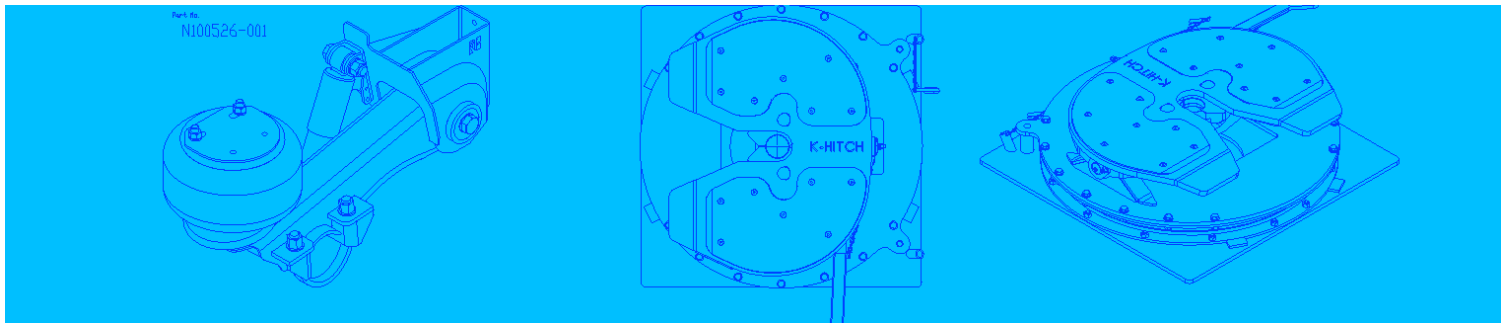

Install the outer slack adjuster washer (evenly space slack adjuster washers either side of the slack adjuster) and circlip. **NOTE:** ensure that the circlip is properly located in the groove in the S-Cam spline.

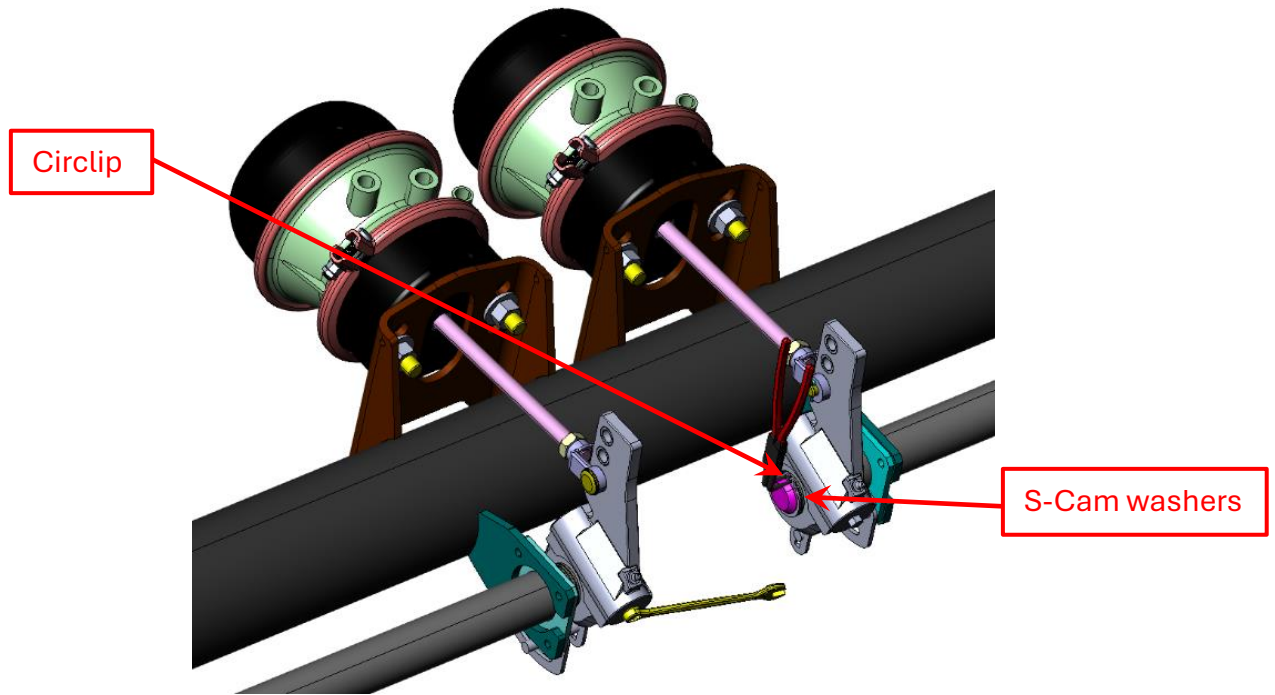

Check the slack adjuster side clearance along the S-Cam spline, minimum of 0.5mm to maximum of 2.0mm. (Slack adjuster washer thickness is 1.0 mm)

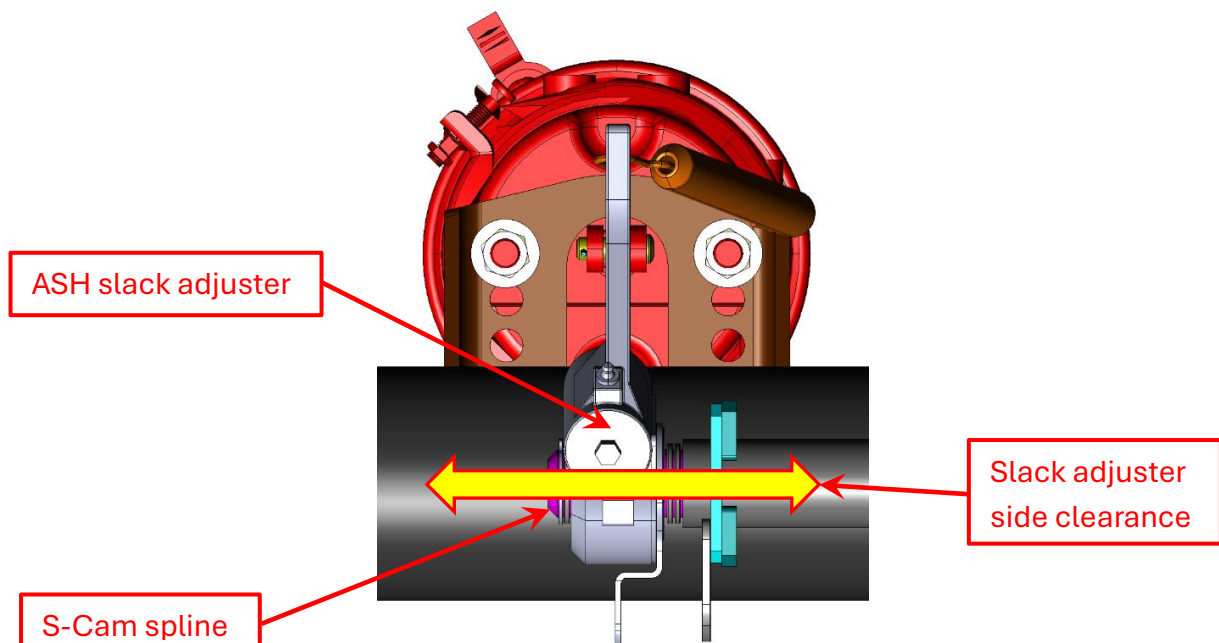

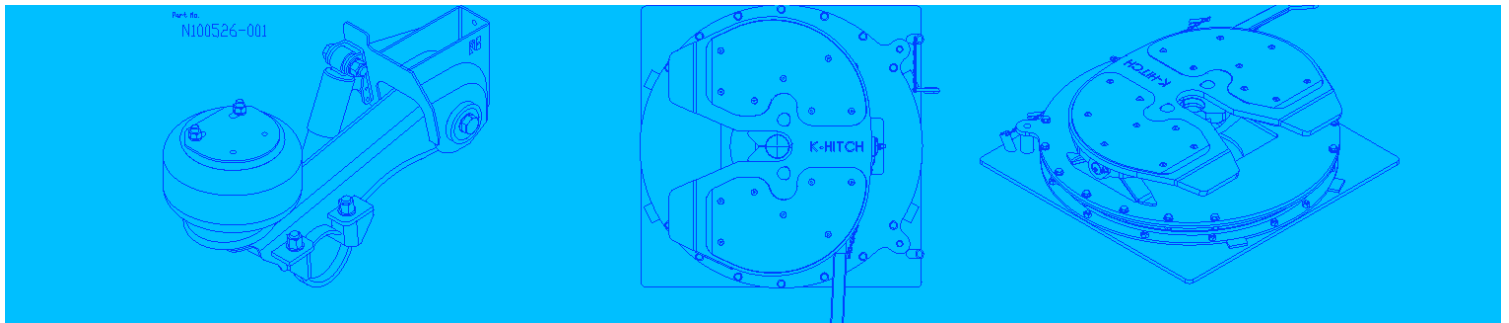

Tighten the clevis lock nut at the torque setting of 68 Nm (50ft-lb). *NOTE: Industry best practice is to hold the clevis with a spanner when torquing the clevis lock nut, to ensure no torsional load is applied to the brake chamber pushrod and the slack adjuster.*

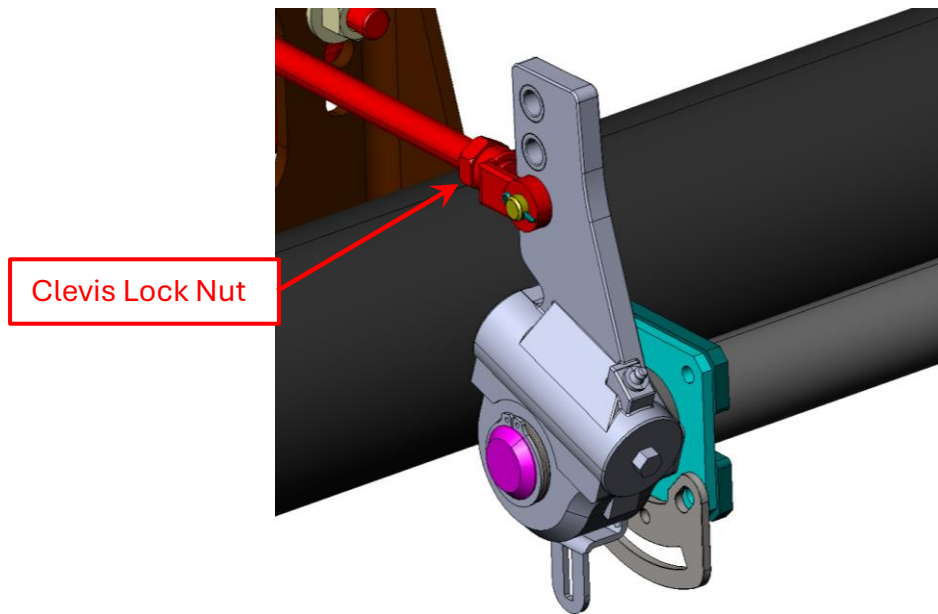

The anchor pin stud is now installed. With the 12 mm ring spanner turn the manual adjustment screw to move the control arm to be central in the control bracket as shown below.

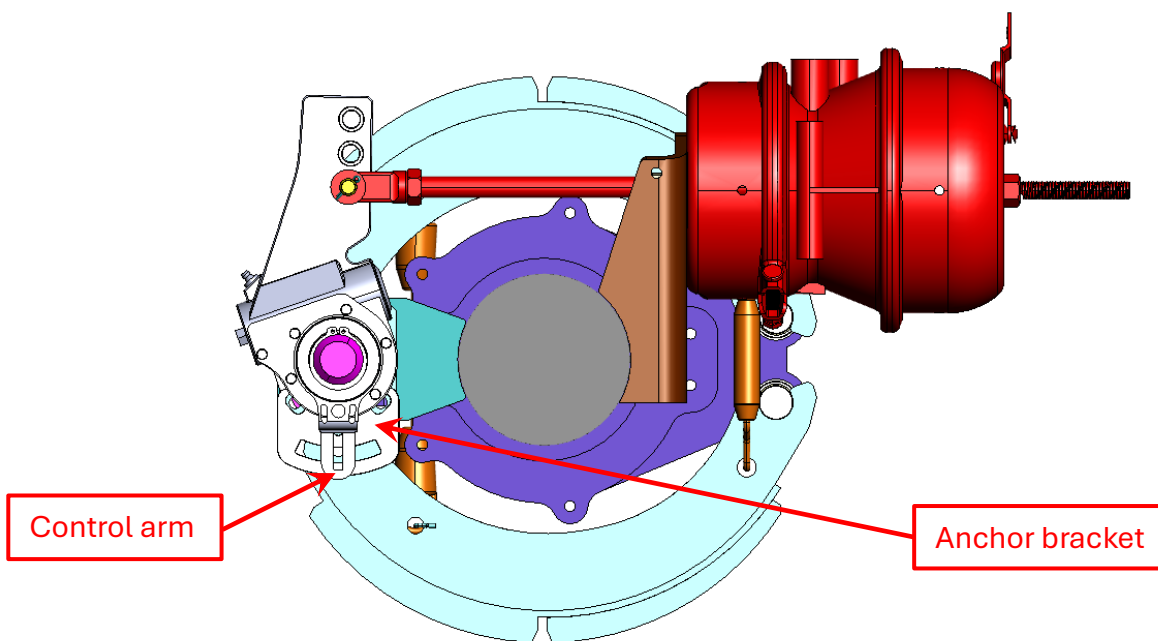

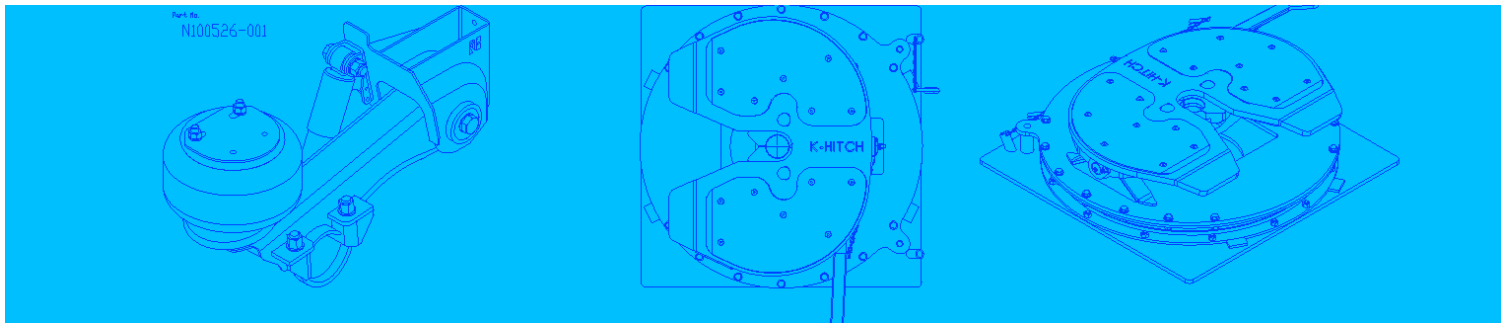

The flattened end of the anchor stud pin can then be pushed through the wear bush in the control arm, from the anchor bracket side.

The threaded section of the anchor pin stud is then pushed back into the slot of the anchor bracket, being careful to ensure that the square locating section at the base of the thread is securely located into the slot of the anchor bracket.

Then fit the anchor stud nut and tension to 54 - 68 Nm (40 - 50 ft-lbs.) as shown below.

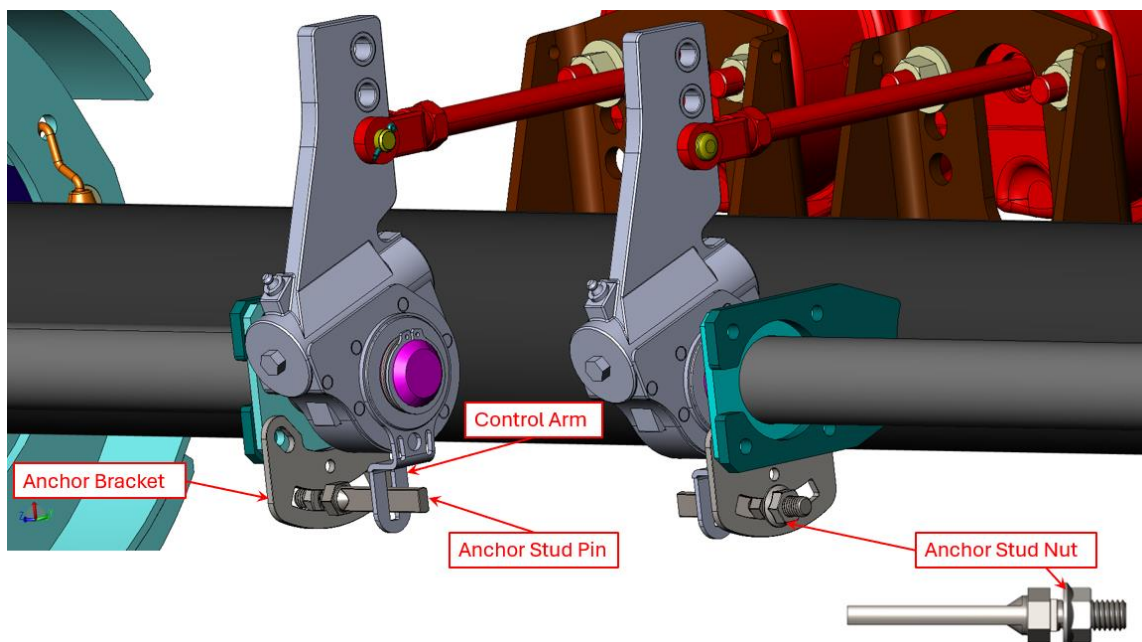

For the final adjustment turn the manual adjuster with the 12mm spanner clockwise until the brake shoes touch the brake drum ( No free play, small 15 Nm preload)

Turn the adjustment screw anti-clockwise 180 degrees, this should give about 20 mm free play. Apply the brakes five times, the ASH slack adjuster should self adjust and reduce the free play.

If the axle is being assembled on the bench and has no air lines, set free play to 6 – 10 mm, by adjusting the Slack adjusters adjustment screw.

After completing the installation, make sure the slack adjuster is properly lubricated.

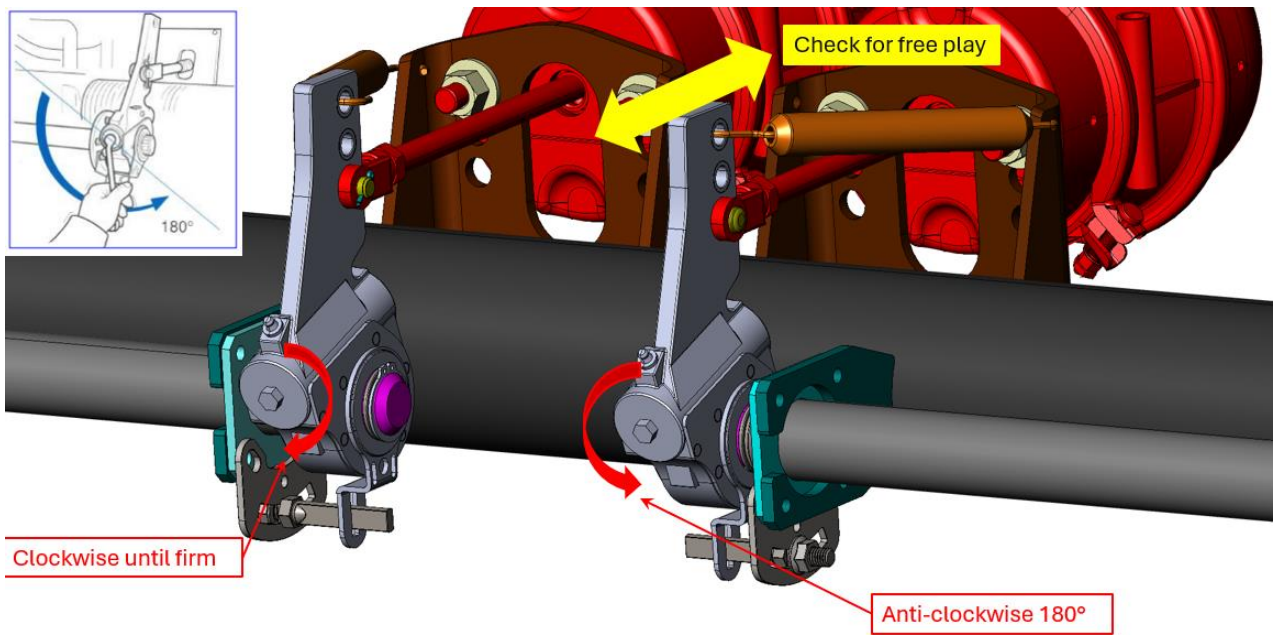
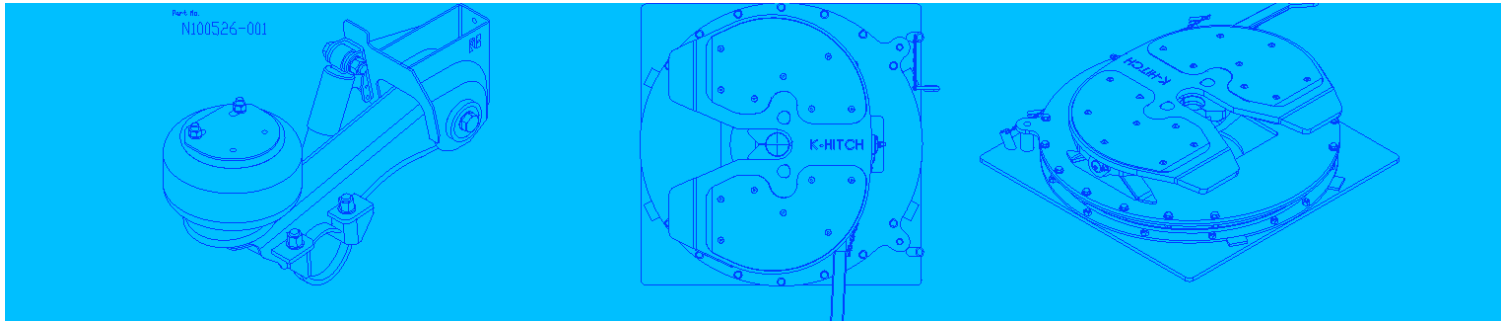

Then fit the return springs between the slack adjusters and the brake chamber mounting bracket.

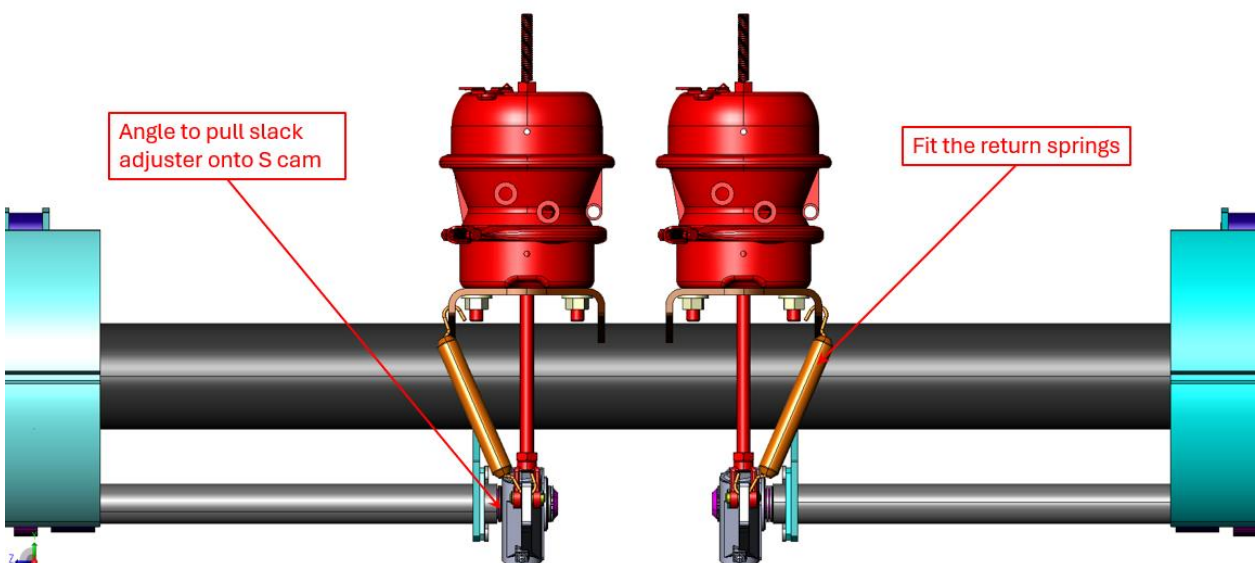

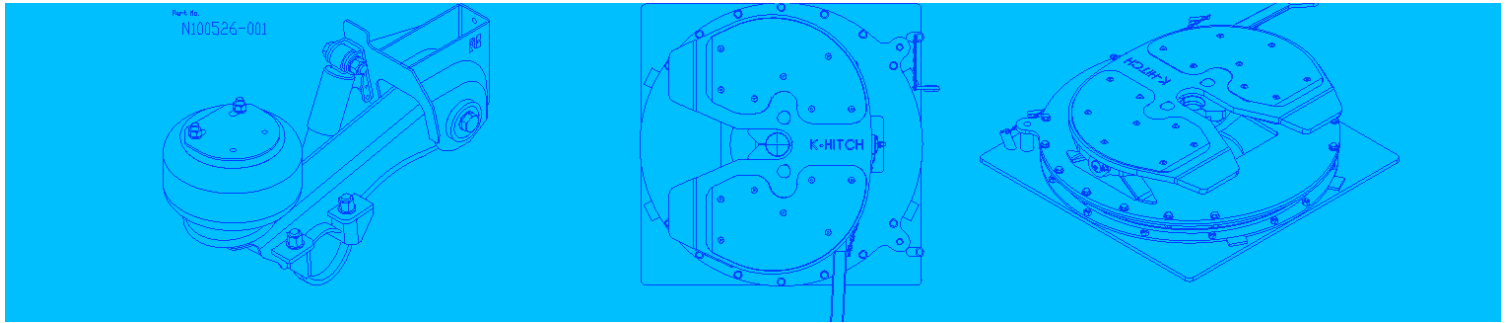

With the brakes not activated there should be an angle of about 105 degrees between the brake chamber pushrod and the slack adjuster line of action as shown below.

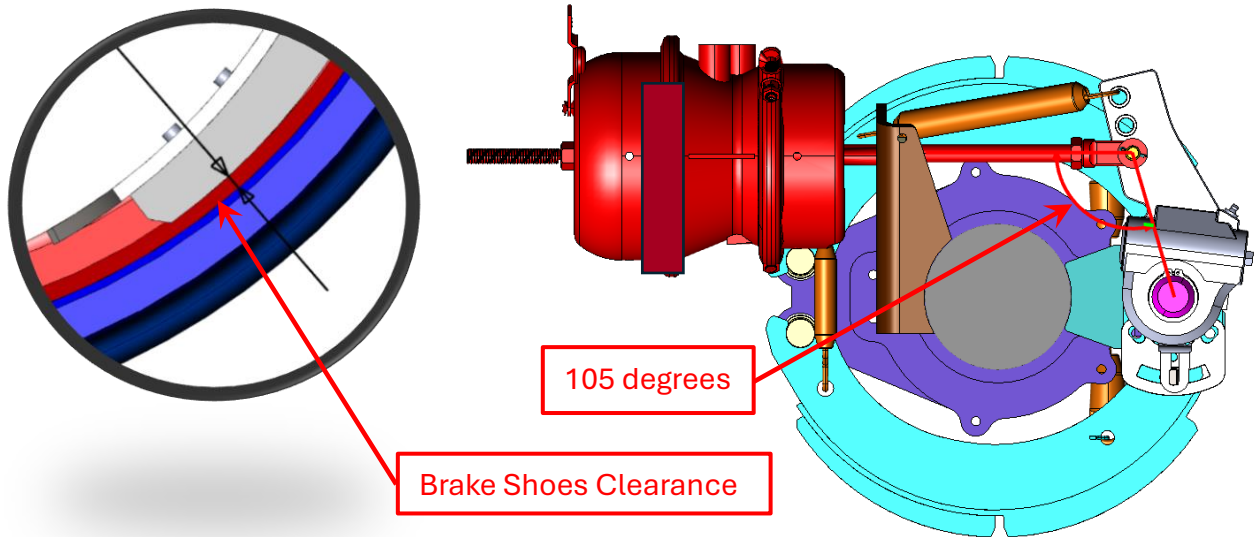

With the brakes fully applied there should be an angle of about 90 degrees between the brake chamber pushrod and the slack adjuster line of action as shown below.

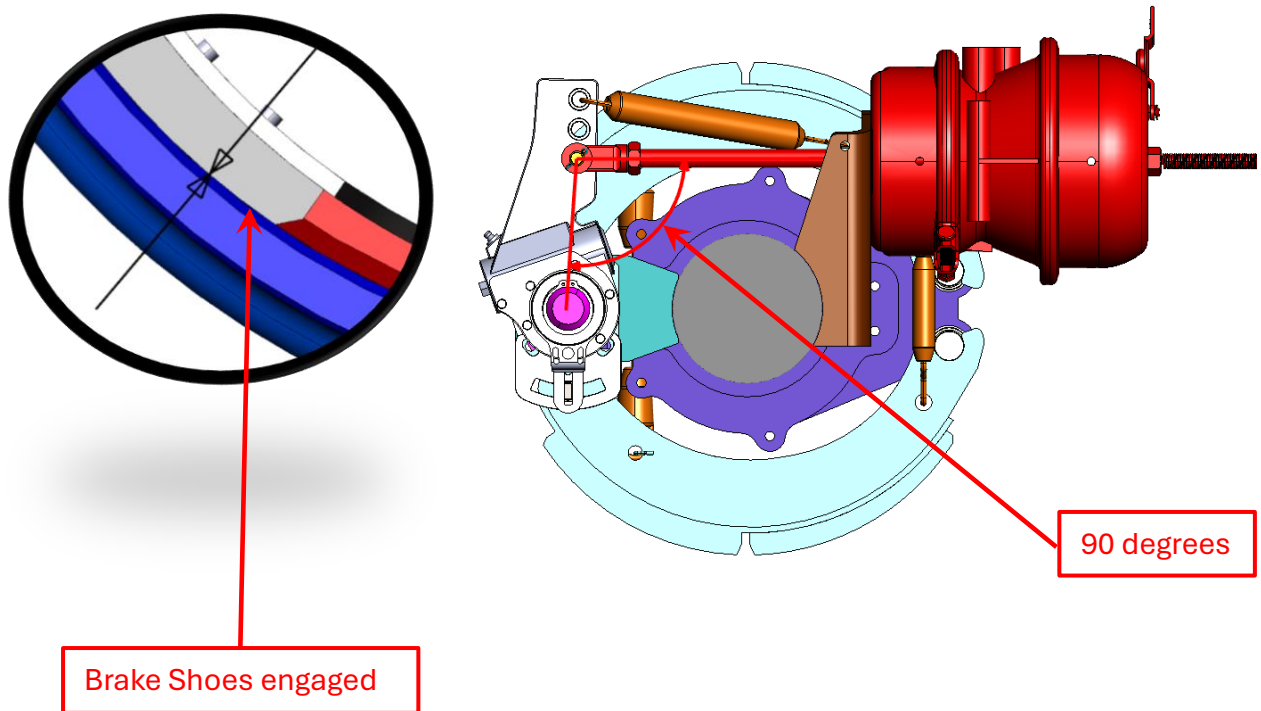

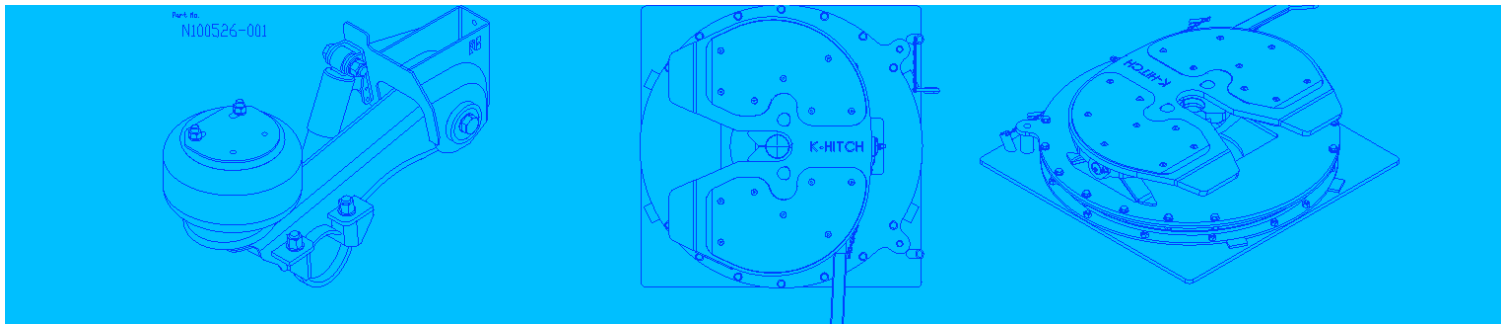

The spring brake chamber can now be uncaged by applying more than 650 kPa air pressure into the park brake air port, undoing the T-Bar release tool nut enough to rotate the T-Bolt release tool 90° anticlockwise and extract it. The T-Bolt release *tool (Caging Bolt)* should then be fitted to the T-Bolt receptacle on the side of the spring brake chamber central aluminum section. Then release the air from the park brake system. *Caution: the pushrod and slack adjuster will move applying the brakes, expelling high pressure air as the air pressure is removed.*

Now check the brake systems operation with compressed air, also check that the red stroke indicator on the brake chamber pushrod is not visible when the brakes are applied, as shown below. ***(If Visible - may require a 75 mm {3"} stroke brake chamber)***



Red Stroke  
Indicator Band