



Part No.
N100526-001

FUWA K-Hitch Australia Pty Ltd

www.khitch.com.au

+61 (03) 9369-0000

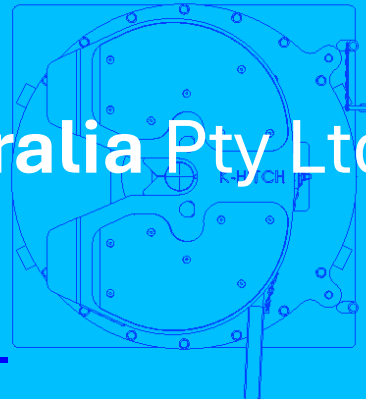

INSTALLATION BULLETIN

Bulletin ID : FKH-INSTL-0024

Issued Date : 3 December 2024

Revision : Rev B

Reference Documents : T001-01 Rev 02-22

ATIS INSTALLATION SUPPLEMENT KI SUSPENSION

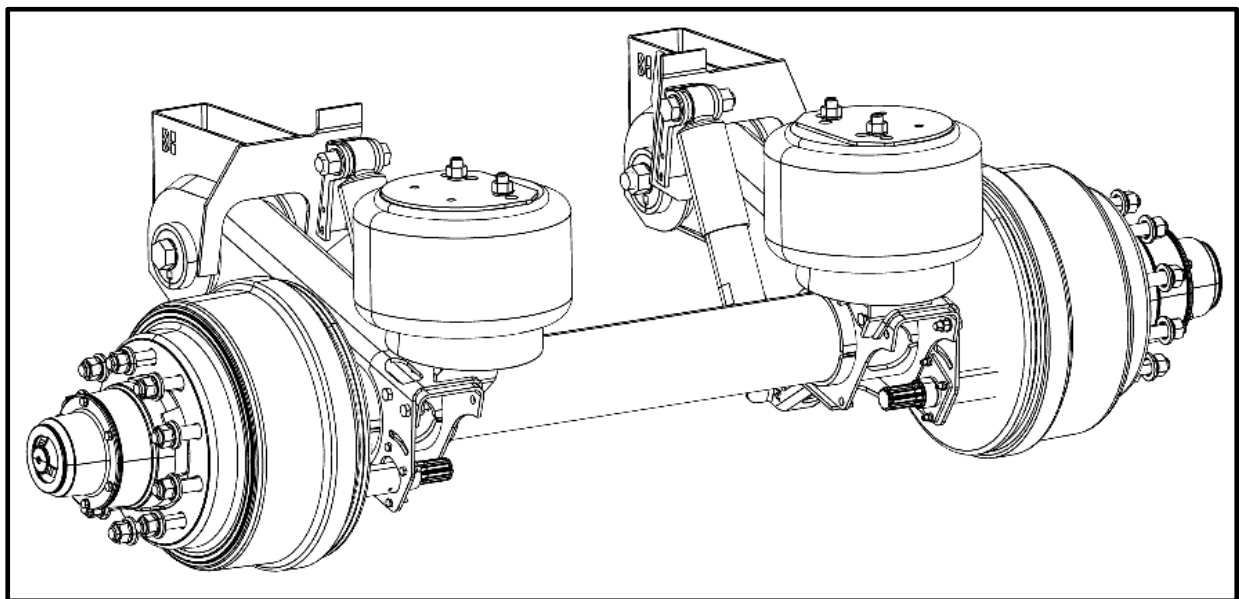

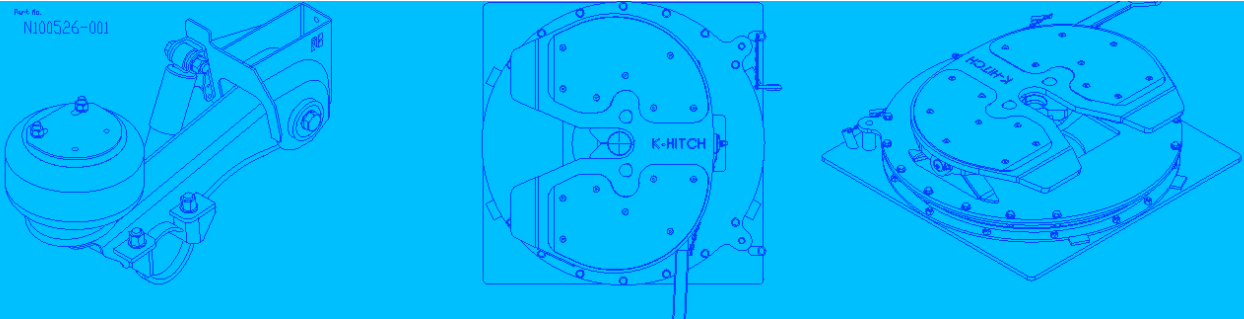

SCOPE

This is a supplementary installation recommendation for fitting the Pressure Systems International (PSI), Automatic Tire Inflation System (ATIS) system onto the FUWA K-Hitch KI suspension and axle configurations as illustrated below.

For the general installation instructions please refer to the Pressure Systems International (PSI), Automatic Tire Inflation System (ATIS) system general installation and maintenance instructions, document number T001-01 Rev 02-22.

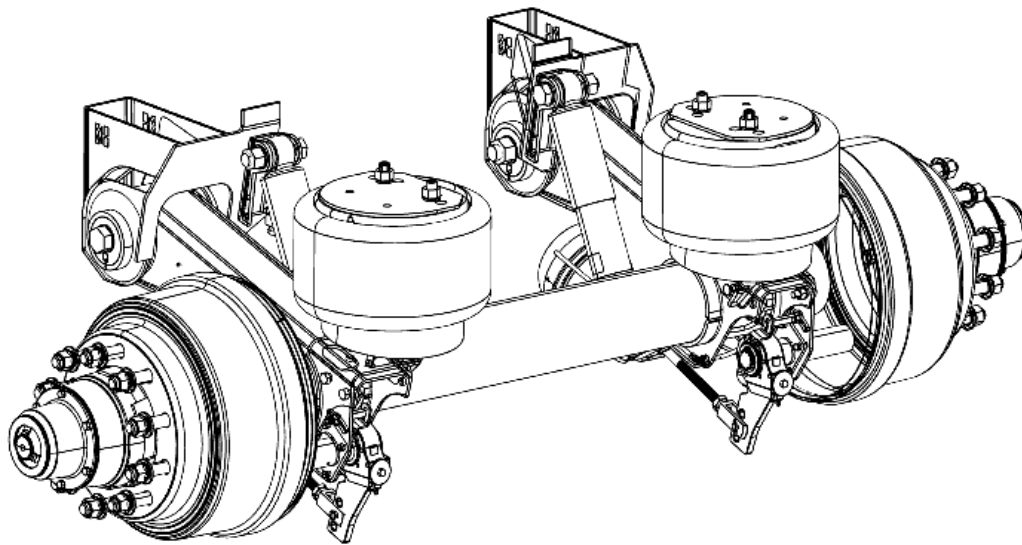

KI Overslung Drum Brake

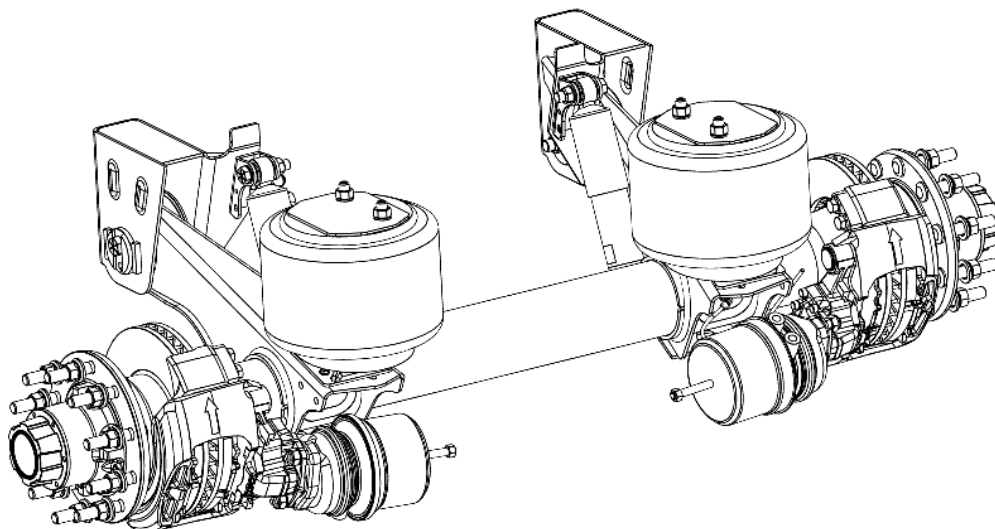

KI Overslung Disc Brake

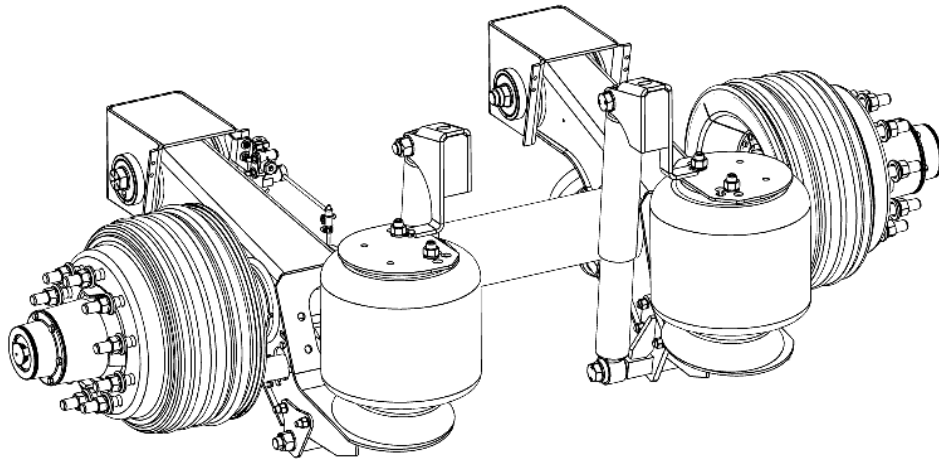
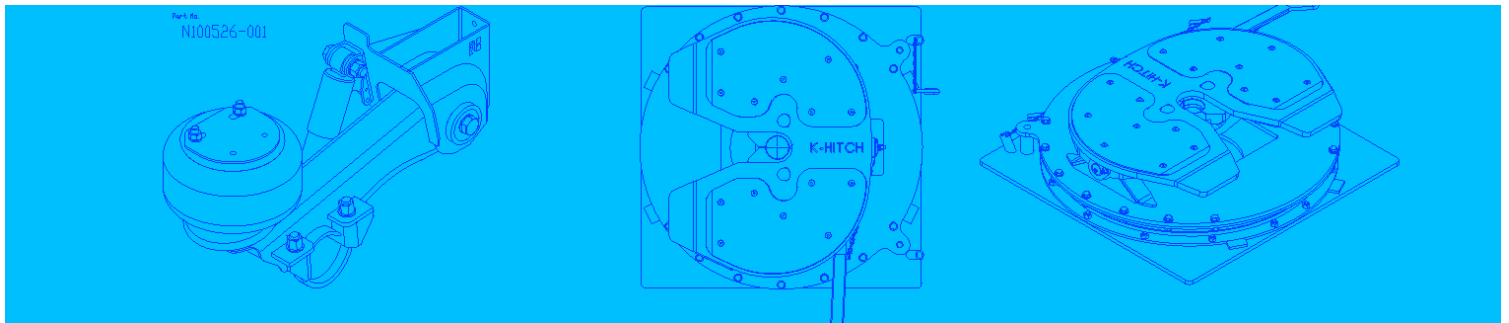

KI Underslung Drum Brake

INSTALLATION RECOMMENDATIONS

Please ensure that the correct Automatic Tire Inflation System (STIS) kit has been supplied for the axle configuration fitted to the trailer.

Pressure Systems International (*PSI*) have provided a document for general installation instructions to fit the Automatic Tire Inflation System (*ATIS*) system to general suspension and axle configurations. For the FUWA K-Hitch KI suspension system with an integral axle and trailing arm the fitment of the pressure fitting into the axle is unique and must follow the recommendations in this document or damage to the axle and potential injury may occur.

Preparation

Please read this document fully in conjunction with the Pressure Systems International (*PSI*) general installation recommendations T001-01 Rev 02-22 in full before starting the installation.

Follow all health and safety, manual handling and company procedures for all work to avoid injury and safely complete the work.

Unpack the Automatic Tire Inflation System (*ATIS*) kit and ensure all of the parts are present and are not damaged.

Make a plan to complete the required tasks in a safe and efficient manner, including post installation quality and functionality testing.

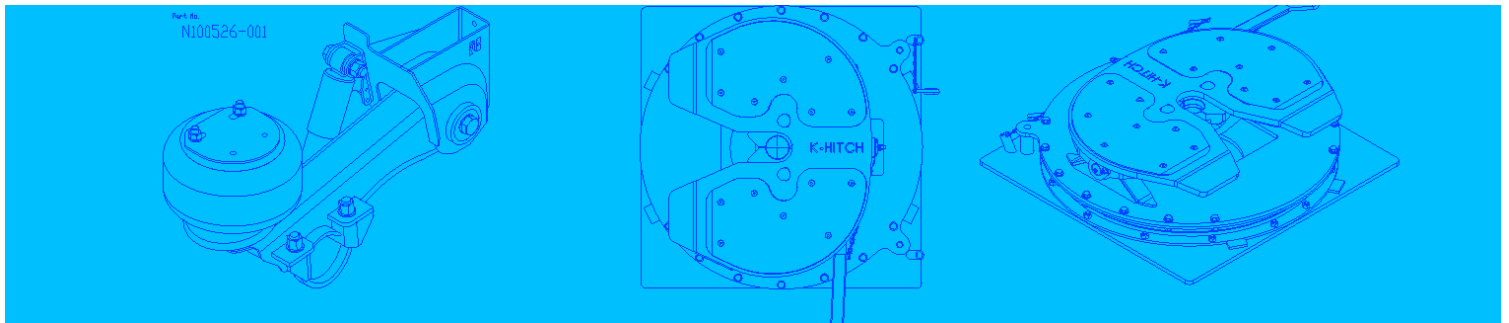

Assembly

The KI suspension and axle assembly consists of a fabricated trailing arm encompassing a support wrap around the lightweight axle tube with a Ø146 mm welded together.

Because of the lightweight axle tube, the Automatic Tire Inflation System (ATIS) air inlet into the axle tube cannot be placed in the common central position as described in the general installation instructions.

For the KI suspension and axle assembly, the Automatic Tire Inflation System (ATIS) air inlet must be placed in the Right-Hand Side (RHS) trailing arm, rear of the axle, in the gap between the axle support wrap as illustrated below.

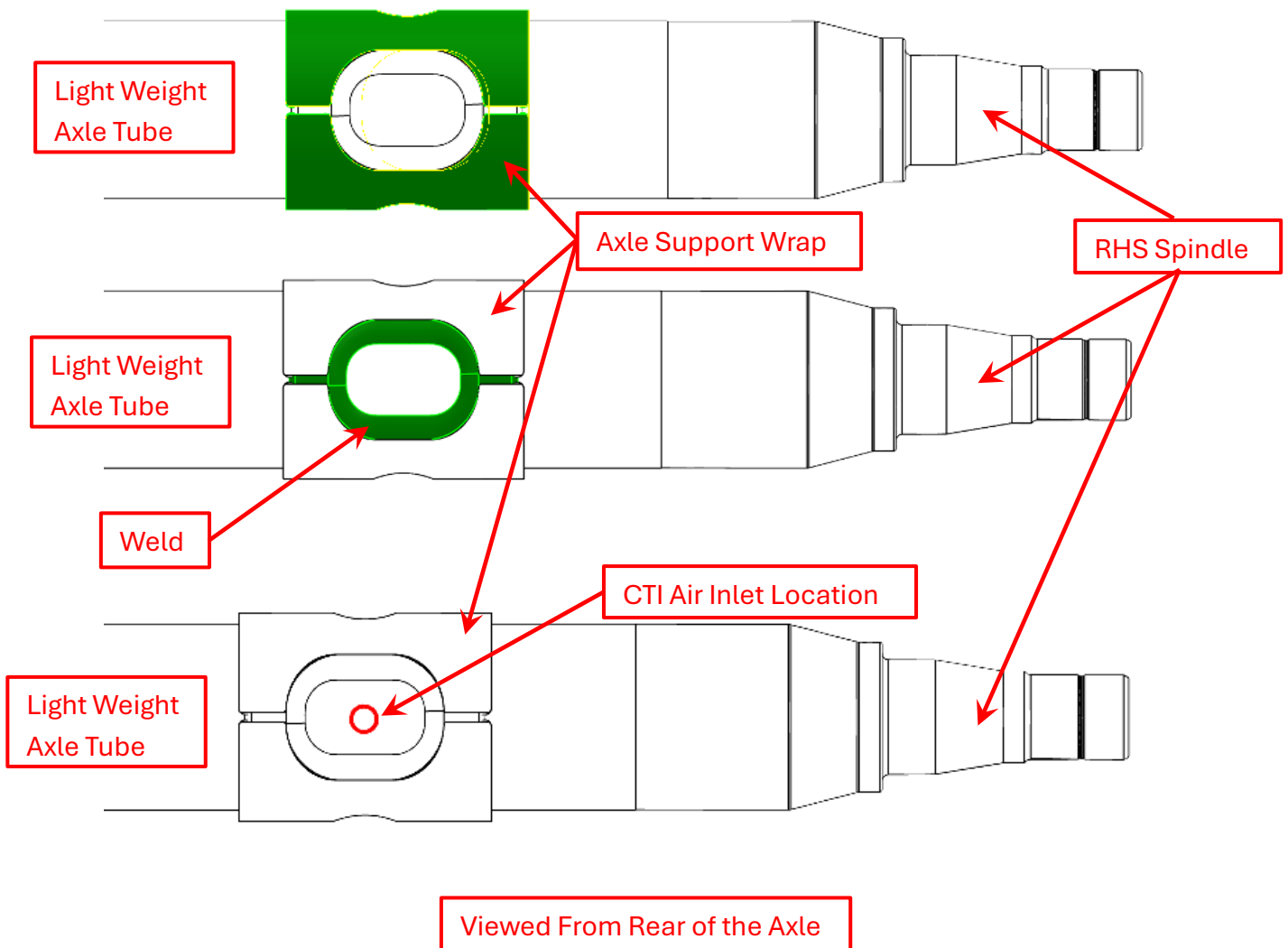

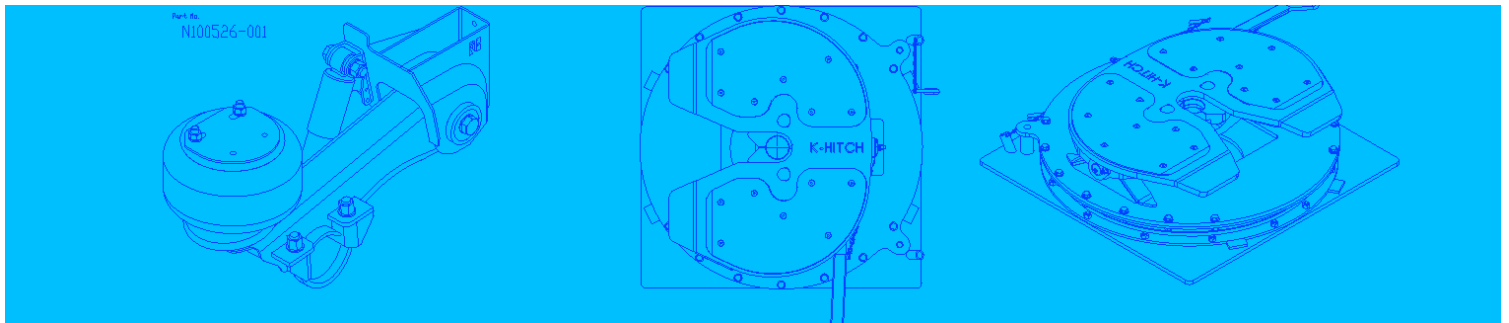

To gain access to the axle wrap clearance area as illustrated above, it may be required to remove components. This will provide room to drill the required hole, tap the required pipe thread and maintain the tools perpendicular to the axle.

For the Overslung drum brake variant, the slack adjuster and anchor pins if fitted need to be removed as shown below.

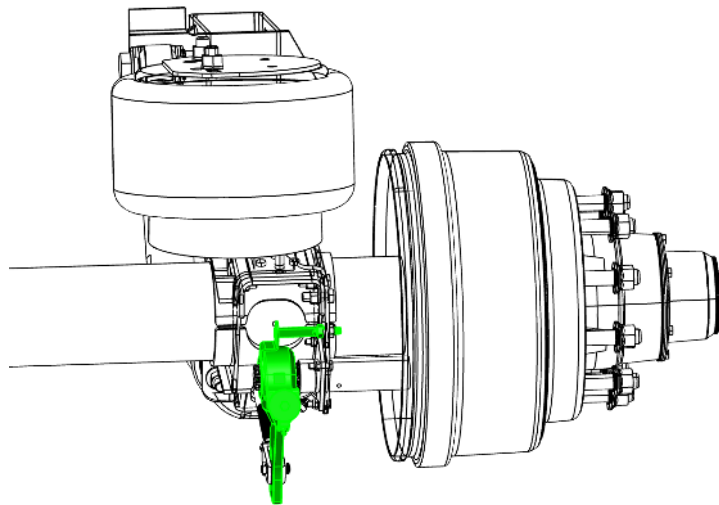

For the Overslung disc brake variant being retro fitted, the brake chamber needs to be removed. This may be accomplished by removing the caliper assembly as shown below.

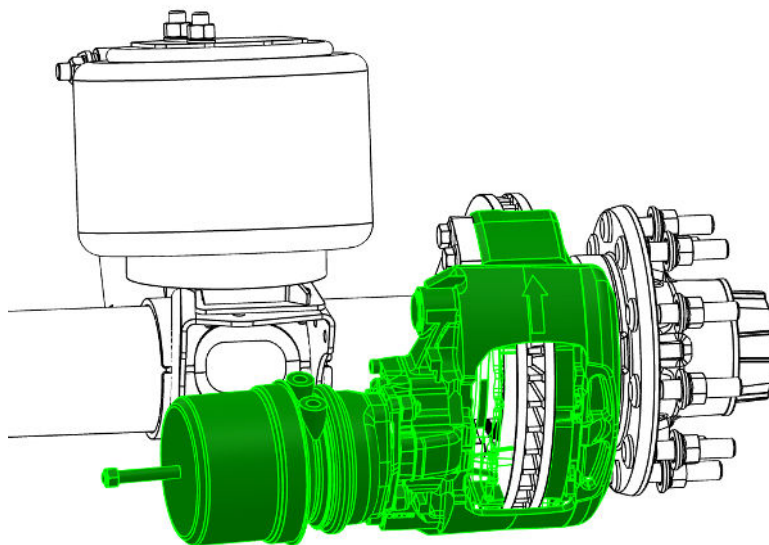

For the Underslung drum brake variant, the airbag needs to be removed to gain access as illustrated below.

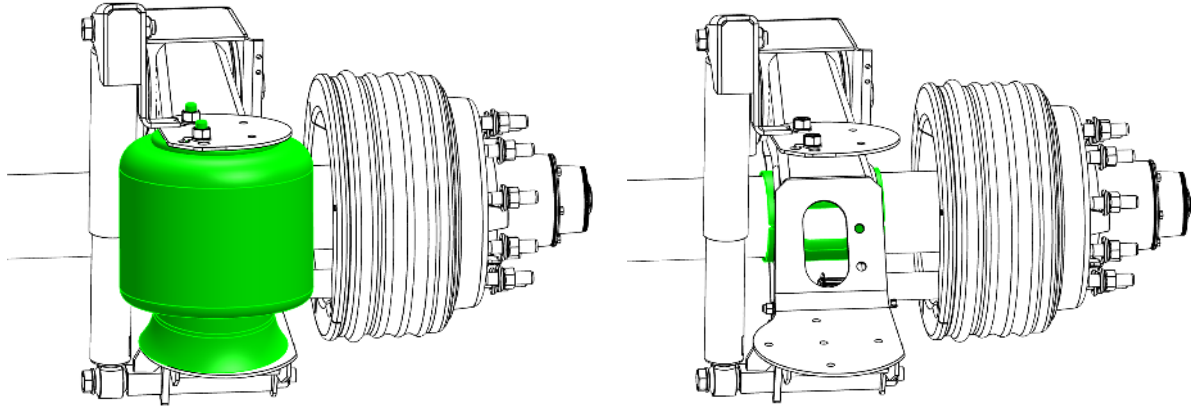
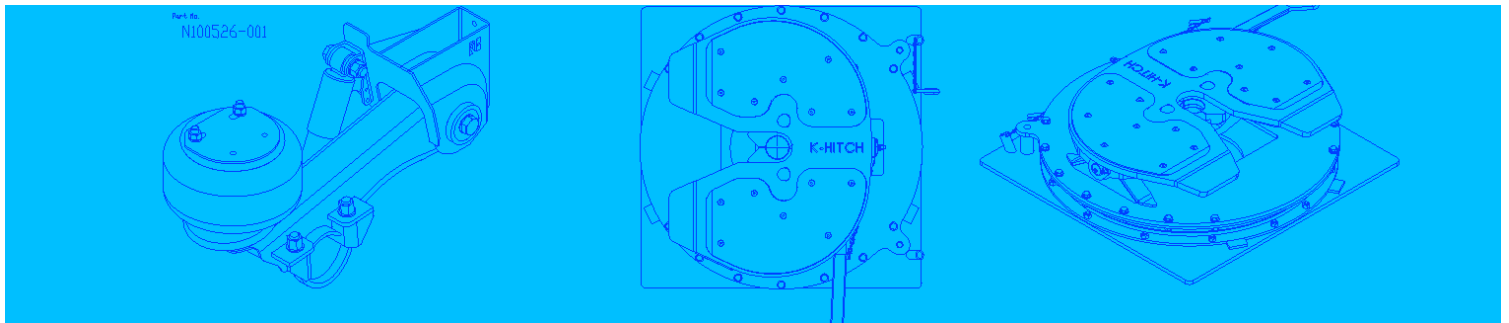

Carefully mark the center of the axle wraps clearance zone, shown below and centre punch the position.

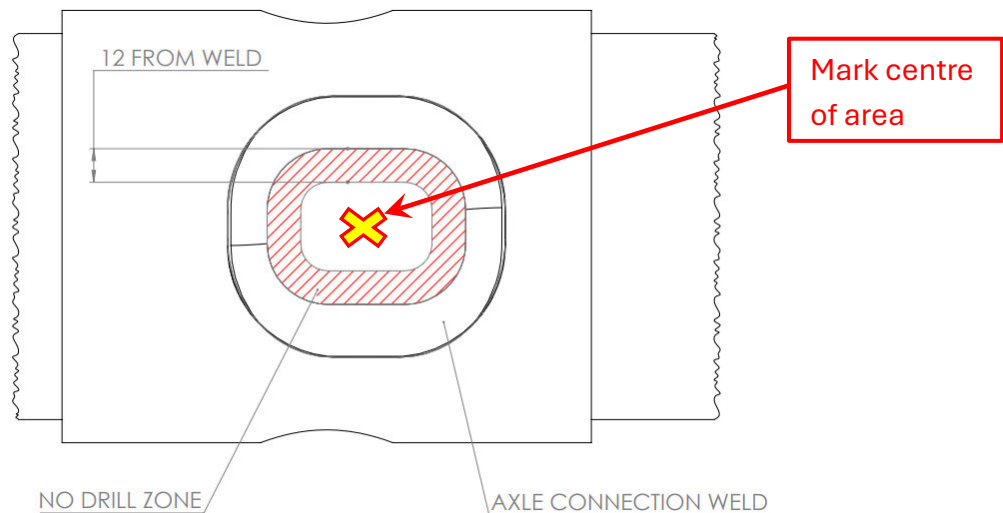

Carefully drill perpendicular to the axle in several drill size steps until the final hole size of 8.73 mm (11/32") is achieved.

Using suitable tapping lubrication, cut the 1/8-27 NPT thread into the 8.73 mm diameter hole drilled into the axle tube (*placing grease around the flutes of the tap will help to catch swarf created from the thread cutting process ensuring it does not fall into the axle tube*). When tapping the hole, keep the tap perpendicular to the axle (*follow industry recommendations for manually tapping a thread*). As the thread is tapered leave 6.35 mm (1/4") to 9.53 mm (3/8") of thread above the axle tube when finished as illustrated below.

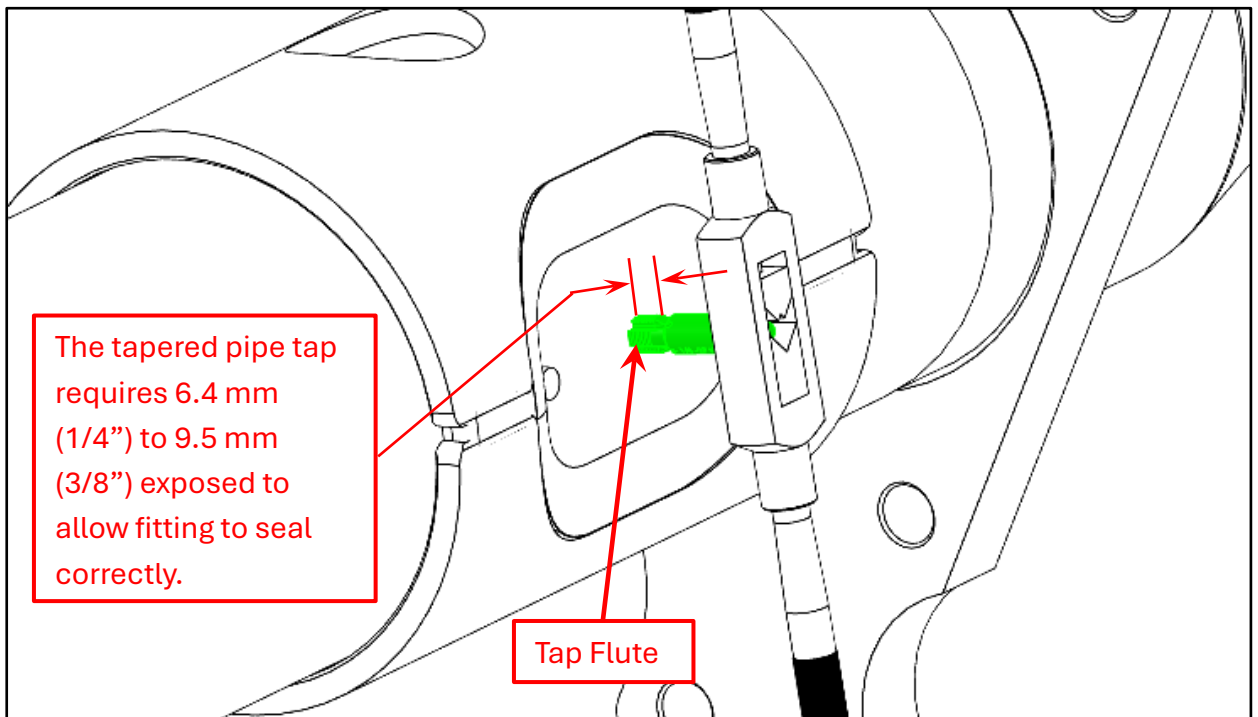
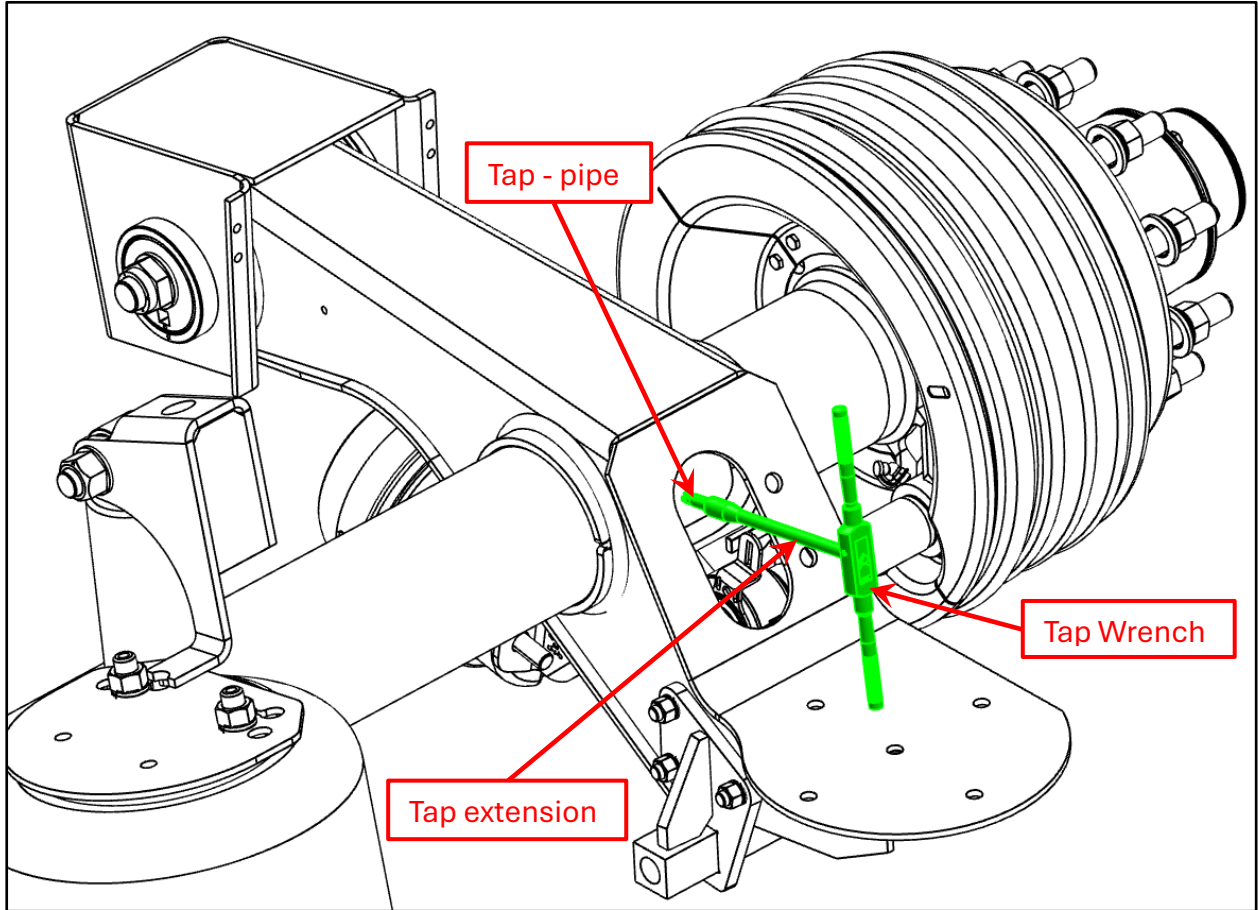
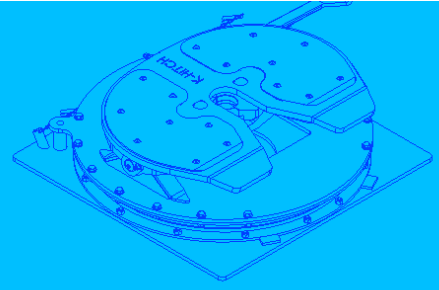
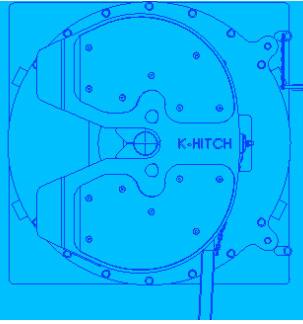
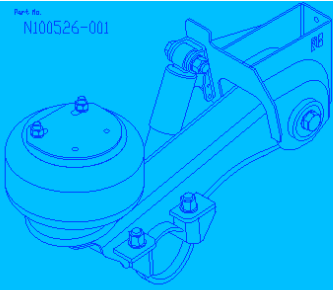

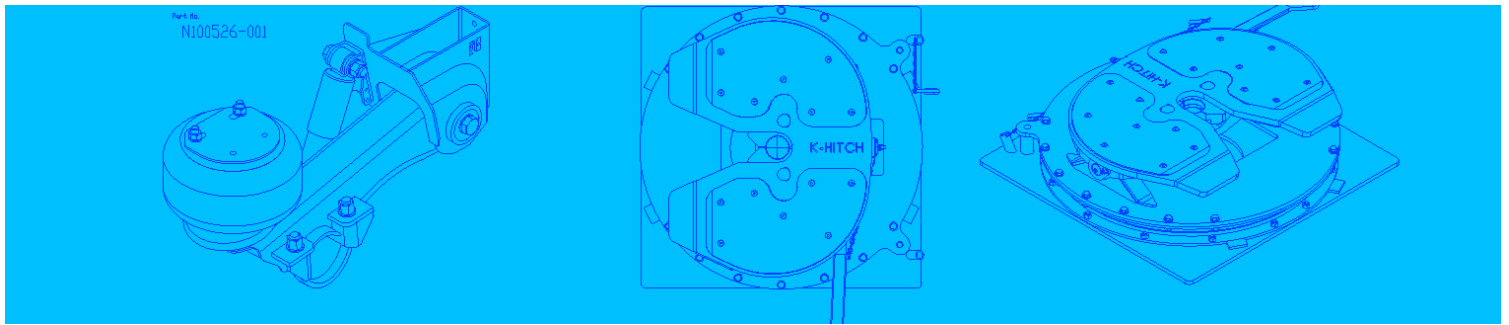

Clean the thread and surrounding axle and then install the air fitting hand tight. Use a ring spanner to tighten approximately 2-1/2 additional turns, making an airtight seal between the air fitting and axle tube using the tapered pipe thread.

NOTE: Current production fittings have sealant pre-applied to the threads. If the fitting is removed from the axle, apply sealant to the threads before installation as illustrated below (*liquid hydraulic thread sealant can also be used*).

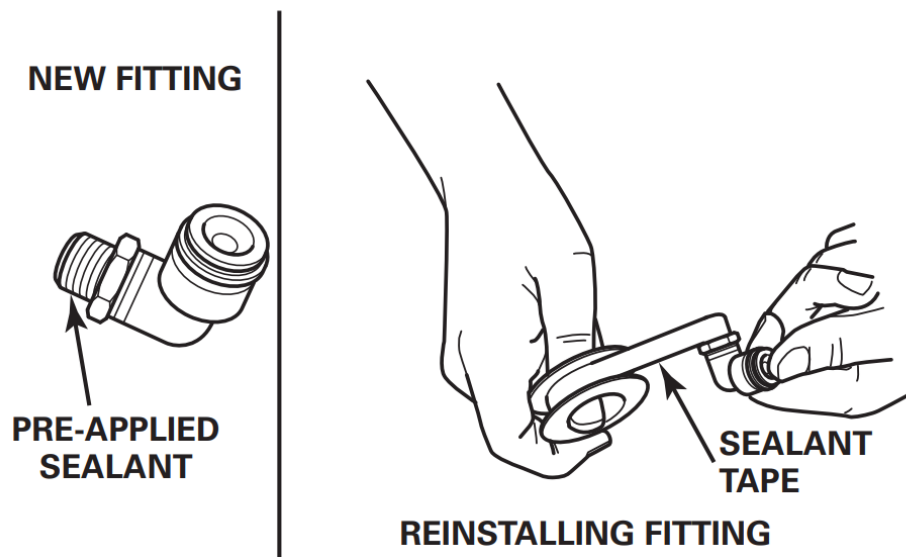

The 1/4" Nylon air tubing can now be carefully cut using the appropriate cutting tool and routed. Protect the tubing against chaffing when passing across metal edges, use grommets and conduit to protect the tubing from contacting sharp edges at hole locations and use appropriate ties, wraps and clips to secure the Nylon air tube.

When routing the 1/4" Nylon air tubing from the axle air inlet fitting, extreme care is required to ensure that clearance is maintained between all moving components and is secure to stop wear from vibration and road debris.

On the KI Overslung drum brake variant, the Nylon air tube must be routed and secured away from the slack adjuster and secure the tube against vibration/wear, as illustrated in the images below.

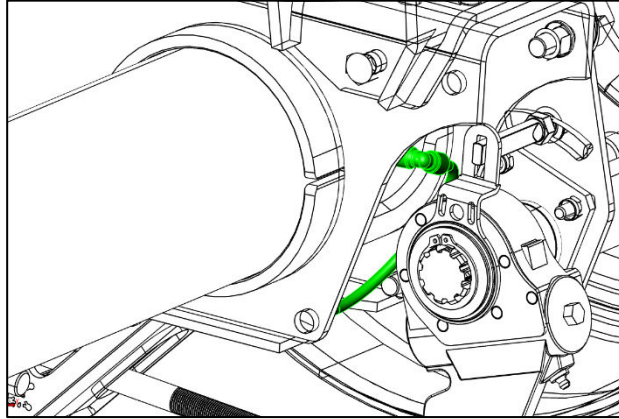
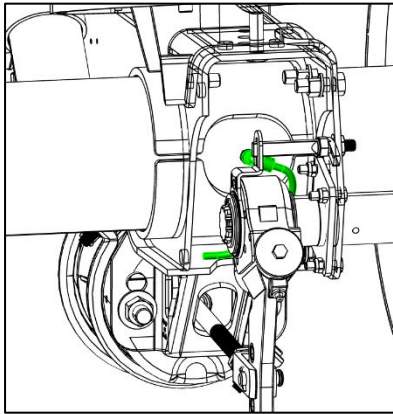
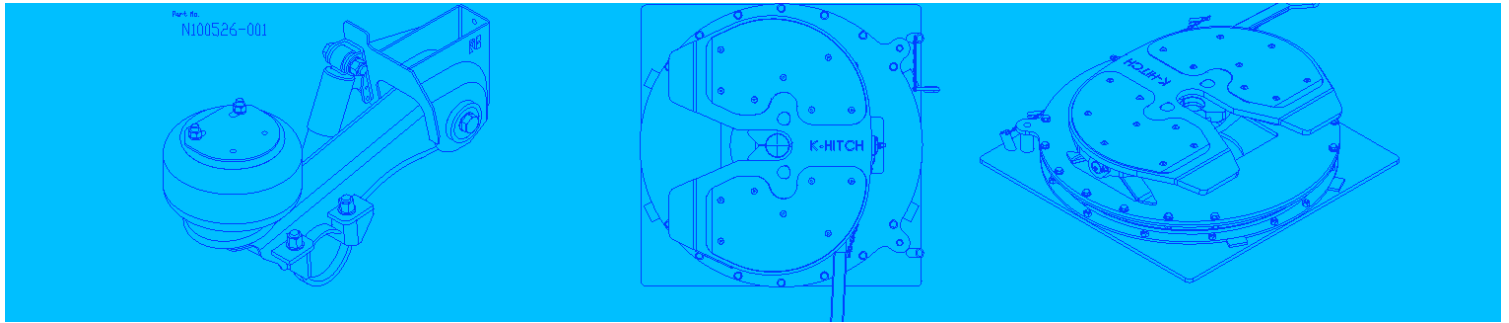

For the KI Overslung disc brake variant, the Nylon air tube must be routed and secured away from the brake chamber and secure the tube against vibration/wear, as illustrated in the images below.

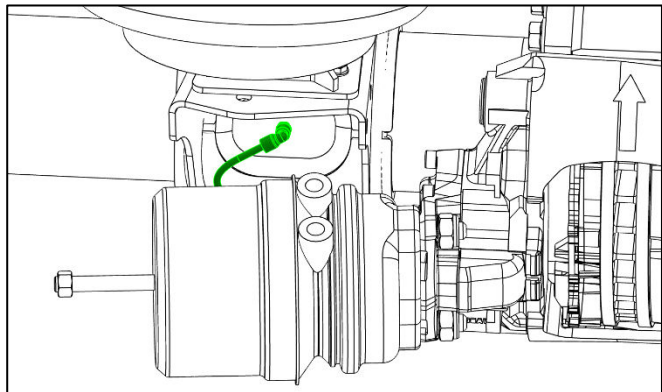
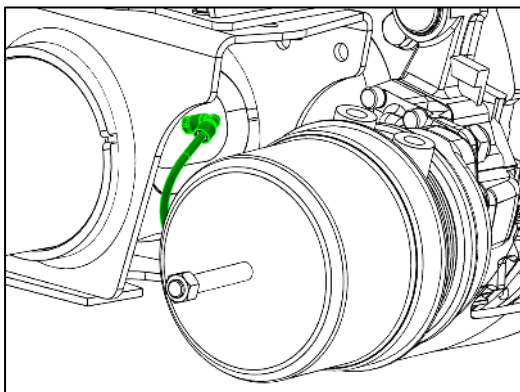

For the KI Underslung drum brake variant, great care must be taken to route the ¼” Nylon air tube away from the slack adjusters and along the trailing arm affixing to the brake chamber hoses. The illustrations below are to provide an indicative routing path.

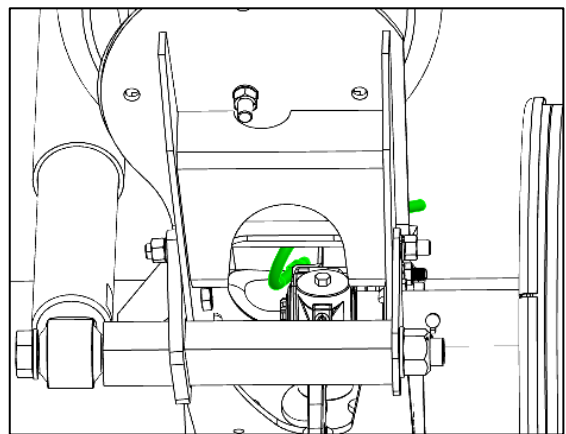
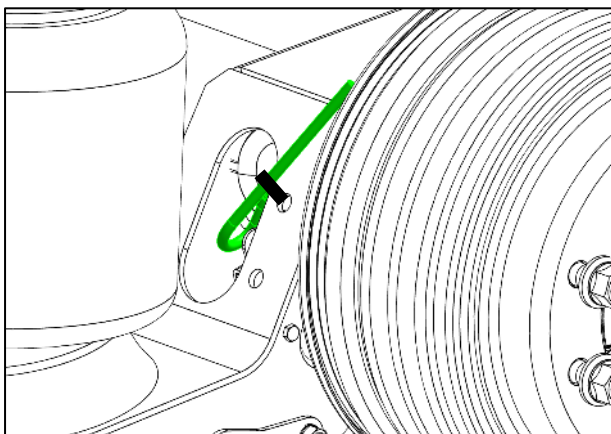

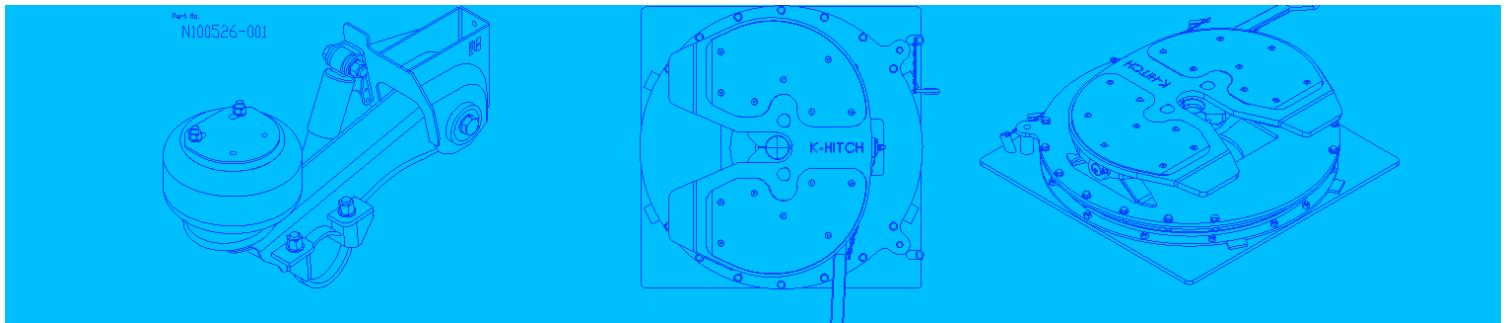

NOTE: Provide sufficient slack in the lines to allow for suspension movement. Use the slack in the existing trailer brake lines as a guide.

It is the installer's responsibility to route air lines and orient axle connector fittings to eliminate interference between slack adjusters and other moving components.

¼" Nylon air tubing has a minimum bend radius of 26 mm (1") and can very easily be crimped over, creating a permanent deformation in the Nylon Air Tube. If this deformation occurs the air tube must be replaced.

The images below provide some recommendations for the routing of the Nylon tubing.

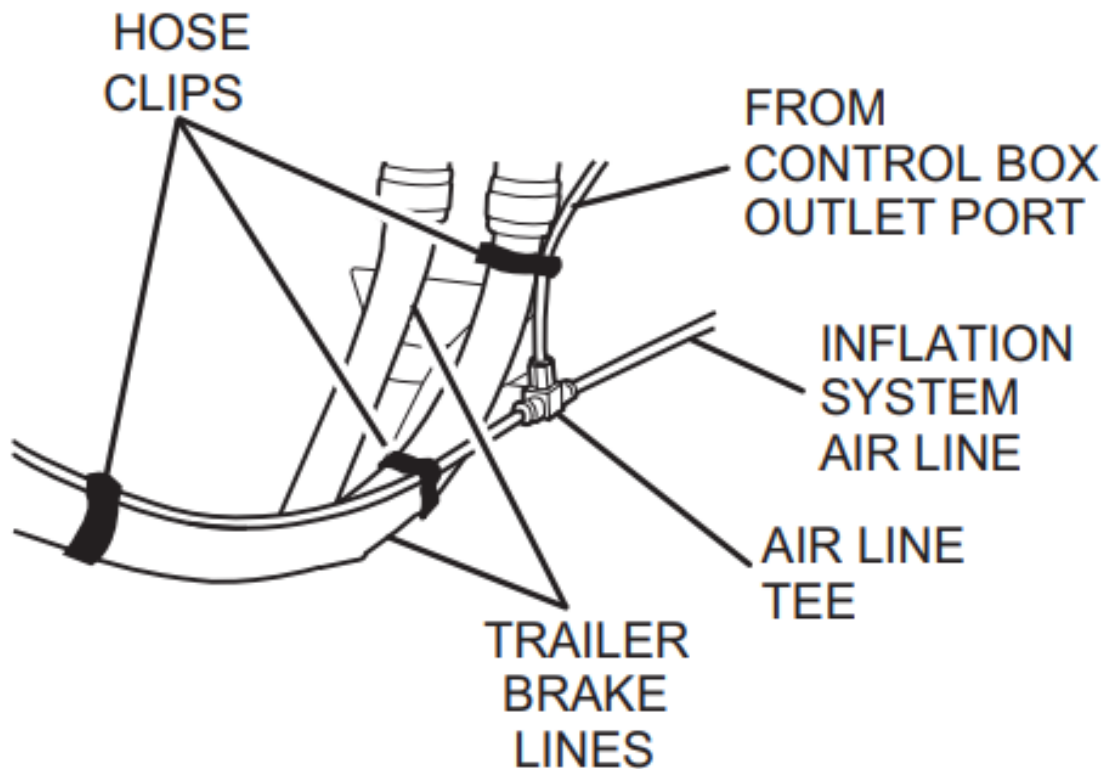

Use hose clip's to suspend the airline tee away from the trailer brake lines to protect them from damage.

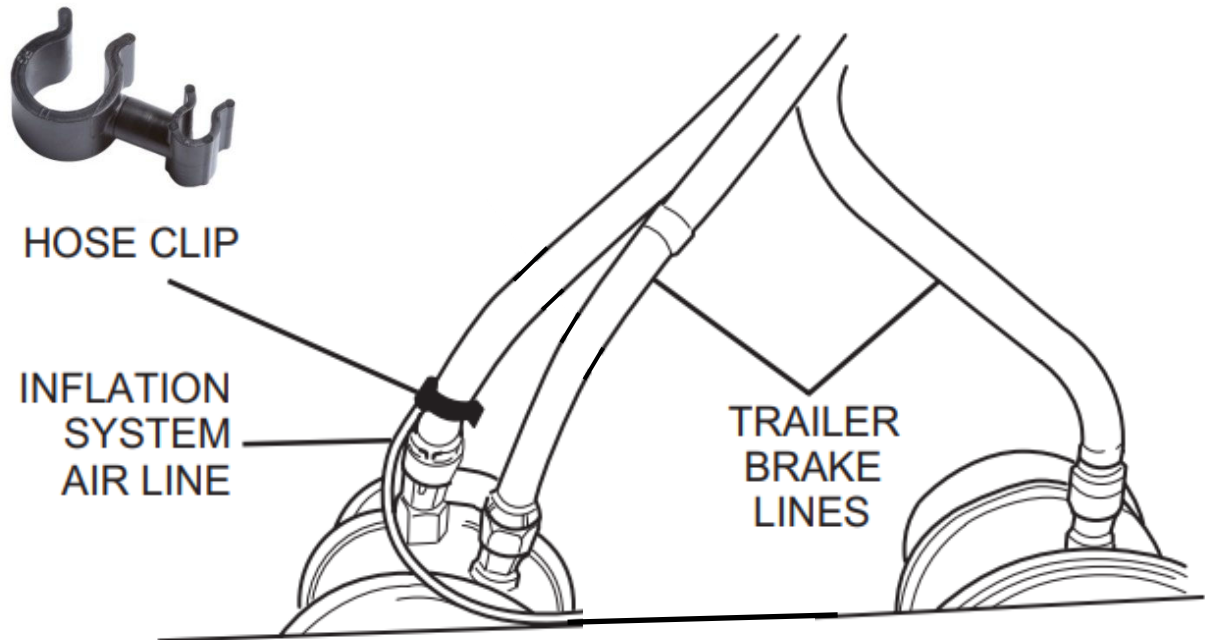
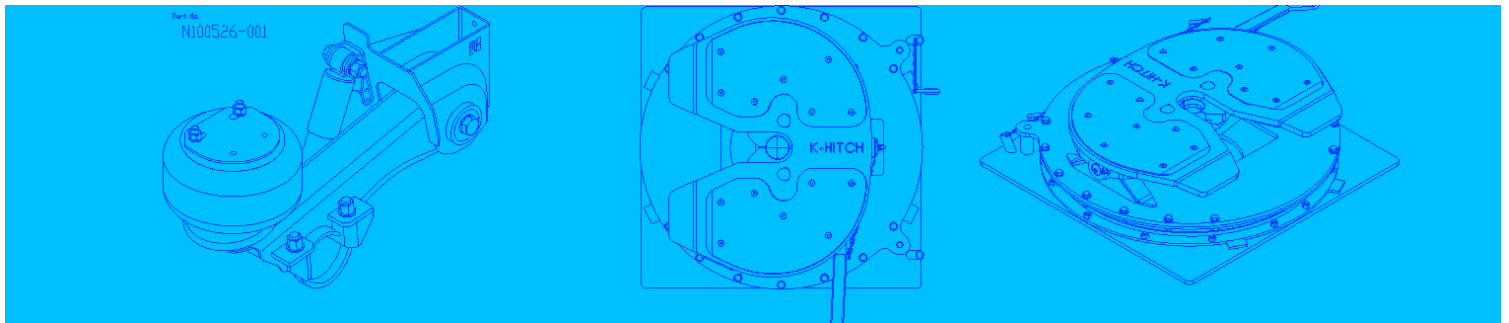

Checks

Check all fittings and the hubcap tee vent with soapy water for air leaks with 650 Kpa (95 PSI) of air pressure applied to the axle.

Use a torque wrench to tighten all fasteners and put a paint pen mark to assist the quality management processes.

Check routing of Nylon air tube to ensure there are no potential failure points and the tube is protected from wear and heat.

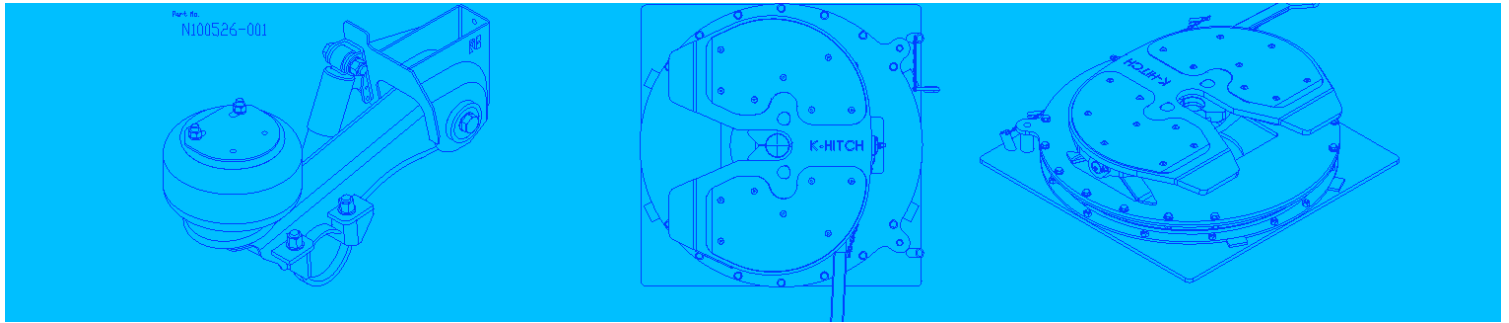

COMPLETE INSTALLATION

For full installation instructions of the Automatic Tyre Inflation System please refer FUWA K-Hitch website.



FUWA K-Hitch Australia Pty Ltd
www.khitch.com.au
+61 (03) 9369-0000

INSTALLATION BULLETIN

Bulletin ID : FKH-INSTL-0062 **Issued Date :** 18 June 2025
Revision : Rev A **Reference Documents :** T001-01 Rev 02-22

AUTOMATIC TYRE INFLATION SYSTEM (ATIS) INSTALLATION INSTRUCTIONS



Page 1