



SERVICE MANUAL

Pneumatic Disc Brake
SN6 - SN7 - SK7

For Tool Case K158880K50

Safety and Environmental Guidelines for Knorr-Bremse Commercial Vehicle Systems products

Note:

The safety advice listed below is applicable to general service and diagnostic work on braking systems. Also observe any recommendations from the axle or vehicle manufacturer concerning towing, jacking-up and securing the vehicle.

Caution!

Knorr-Bremse is not liable for any costs and damage caused by improper installation and use of Knorr-Bremse aftermarket products, in particular in the event of (i) use in non-approved applications and/or use in non-compliance with the technical specifications and installation instructions, (ii) incorrect installation or removal of Knorr-Bremse aftermarket products and (iii) failure to observe instructions on the use of tools.

In addition to product-specific installation and hazard warnings, the following precautions and additional hazard warnings must be observed before and during work on and around compressed air systems:

1. Always wear safety glasses when working with air pressure.
2. Never exceed the vehicle manufacturer's recommended air pressures.
3. Never look into air jets or direct them at anyone.
4. Never connect or disconnect a hose or line containing pressure; it may whip as air escapes.
5. When removing or servicing a product, ensure all pressure related to the specific system it is contained in has been depleted to 0 bar. Be aware that if the vehicle is equipped with an air dryer system, it can also contain air pressure along with its purge reservoir, if fitted, even after pressure has been drained from the other reservoirs.
6. If it is necessary to drain the air pressure from reservoirs, etc., keep away from brake actuator push rods and levers since they may move as system pressure drops. On vehicles fitted with air suspension, it is advised when undertaking such work, to support the chassis from sudden lowering and therefore prevent any possibility of being trapped between the chassis and axle or ground.
7. Park the vehicle on a level surface, apply the parking brakes, and always chock the wheels as depleting vehicle air system pressure may cause the vehicle to roll.
8. When working under or around the vehicle, and particularly when working in the engine compartment, the engine should be shut off and the ignition key removed. Where circumstances require that the engine be running, **EXTREME CAUTION** should be taken to prevent personal injury resulting from contact with moving, rotating, leaking, heated or electrically charged components. Additionally, it is advisable to place a clear sign on or near the steering wheel advising that there is **"WORK IN PROGRESS ON THE VEHICLE"**.
9. When working on vehicles equipped with air suspension, to guard against injury due to unexpected downward movement of the chassis caused by sudden pressure loss in the suspension system, ensure that the vehicle chassis is mechanically supported with a 'prop' between the chassis and the axle or between the chassis and the ground.
10. Examine all pipework for signs of kinks, dents, abrasion, drying out or overheating. Be aware that kinks in pipework may result in air pressure being trapped in the pipework and associated equipment. Replacement hardware, tubing, hose, fittings, etc. must be of equivalent size, type and strength as original equipment and be designed specifically for such applications and systems. Check the attachment of all pipework; it should be installed so that it cannot abrade or be subjected to excessive heat. Only use tools specially designed for cutting pipes in order to prevent incorrect cutting and, in particular, to avoid shavings remaining in the pipes or other impurities which may later lead to leaking connections and subsequent malfunctions of the system.
11. Components with stripped threads or damaged/corroded parts must be replaced completely. Do not attempt repairs requiring machining or welding unless specifically stated and approved by the vehicle or component manufacturer.
12. Never attempt to install, remove, disassemble or assemble a device until you have read and thoroughly understood the recommended procedures. Some units contain powerful springs and injury can result if not properly dismantled and reassembled. Use only the correct tools and observe all precautions pertaining to use of those tools.
13. Before removing any device note its position and the connections of all pipework so that the replacement/serviced device can be properly installed. Ensure that adequate support or assistance is provided for the removal/installation of heavy items.
14. We highly recommend to use only genuine replacement parts, components, and kits as supplied by Knorr-Bremse or the vehicle manufacturer containing original Knorr-Bremse parts. Knorr-Bremse will not be liable for any issues arising from the usage of non-Knorr-Bremse products. Only use the recommended tools as specified in related Knorr-Bremse instructions.
15. The serviced or replaced product must be checked for correct function and effectiveness.
16. If products have been dismantled, serviced or replaced, whose performance could affect braking performance or system behaviour, this should be checked on a roller dynamometer. Bear in mind that a lower performance may be experienced during the bedding-in phase if new brake pads/linings and/or brake discs/drums have been fitted.
17. The use of impact screwdrivers or impact wrenches in conjunction with Knorr-Bremse service tools for air disc brakes is not permitted. The service tools are not designed for such use. It is likely that the tools or the vehicle will be damaged and there is a serious risk of injury.
18. Do not use compressed air to clean the disc brake. Avoid air contamination of brake dust.

19. Prior to returning the vehicle to service, make certain that all components and the complete brake systems are leak free and restored to their proper operating condition.
20. During service work on vehicles with electronic parking brake, service or parking brake, or bus stop temporary hold brake, the brake system must be set to service and maintenance mode. Please also observe the instructions of the vehicle manufacturer.

Welding

To avoid damage to electronic components when carrying out electrical welding, the following precautions should be observed:

1. In all cases, before starting any electrical welding, remove all connections from any electronic control units or modules, noting their position and the order in which they are removed.
2. When re-inserting the electrical connectors (in reverse order) it is essential that they are fitted to their correct assigned position - if necessary this must be checked by PC Diagnostics.

Disposal of Waste Equipment by Business Users in the European Union

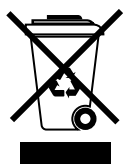

This symbol on the product, packaging or in user instructions, indicates that this product must not be disposed of with other general waste. Instead, it is your responsibility to dispose of the waste electrical and electronic parts of this product by handing them over to a company or organisation authorised for the recycling of waste electrical and electronic equipment. For more information about arrangements for waste equipment disposal please contact your Knorr-Bremse distributor or local Knorr-Bremse representative.

Disclaimer: The information contained in this document is intended for the exclusive use of trained persons within the commercial vehicle industry, and must not be passed on to any third party.

All recommendations regarding products and their servicing or usage are with reference to Knorr-Bremse products and should not be considered applicable to products from other manufacturers.

This information does not purport to be all-inclusive and no responsibility is assumed as a result of its use. We cannot accept any liability nor offer any guarantee regarding data accuracy, completeness or timeliness. The information does not represent any guarantee or ensured characteristics of the Products or Systems described.

No liability can be accepted based on the information, its use, recommendations or advice provided. In no event may we be held liable for any damage or loss except in the case of wilful intent or gross negligence on our part, or if any mandatory legal provisions apply.

The information contained herein is subject to alteration without notice and therefore may not be the latest release. Please check our website mytruckservices.knorr-bremse.com for the latest update or contact your local Knorr-Bremse representative. The figurative mark "K" and the trademarks KNORR and KNORR-BREMSE are registered in the name of Knorr-Bremse AG. Additional terms and conditions apply; please refer to our website truckservices.knorr-bremse.com for full Disclaimer.

Any legal disputes arising from the use of this information shall be subject to German law.

Note: If service work is carried out on a vehicle based on information provided herein, it is the responsibility of the workshop to ensure the vehicle is fully tested and in full functional order before the vehicle is returned into service. Knorr-Bremse accepts no liability for problems caused as a result of appropriate tests not being carried out.

This disclaimer is a translation of a German text, which should be referred to for all legal purposes.

Copyright © Knorr-Bremse AG - all rights reserved, including industrial property rights applications. Knorr-Bremse AG retains any power of disposal, such as for copying and transferring.

Revision Details

Rev. 004	December 2024	Layout updated and safety advise moved to pages 2 and 3. No technical changes
Rev. 003	June 2022	Additional safety advise added to page 5 and 29
Rev. 002	December 2020	Diverse changes throughout and new Double Roll Bearing added

Overview of Tool Kits and Service Manuals for Knorr-Bremse Air Disc Brakes

Brake	Tool Kit	Supplemental Kit	Service Manual
SB5... SB6... SB7...	II37951004* K158880K50		C16352-#
SN5...	K037001		Y015044-#
SN6... SN7... SK7...	K039062K50* K158880K50	K209211K50	Y006471-#
SL7... SM7...	K039062K50* K158880K50	K209211K50	Y081564-#
ST7...	K158880K50		Y173241-#
SyD7	K158880K50		Y416977-#
SyA7 SyR7	K182957K50		Y458802-#
SyT7	K182957K50		Y418754-#

* These Tool Kits are no longer produced and now replaced by Tool Kit **K158880K50**.

To service the new Double Roll Bearing of the caliper's floating bearing side, additional tools are required which are supplied in the supplemental kit **K209211K50**.

- Refer to website for latest revision truckservices.knorr-bremse.com

1. Overview	7
1.1 Disc Brake Components	7
1.1.1 Identification of the Guide and Seal Kit Variants	8
1.2 Brake Identification and Service Kits	9
1.2.1 Wear Indicator Kits	10
1.3 Brake Disc	10
2. General Information	11
2.1 Service Tools	11
2.2 Diagnostic Equipment	11
2.3 Lubricant.	11
2.4 Torque Requirements.	11
3. Description and Function.	12
3.1 Disc Brake Sectioned View.	12
3.2 Description of Operation (Floating caliper principle)	13
4. Inspection Points	14
4.1 Safety Instructions for Service Work and Repair Work	15
5. Functional and Visual Check	16
5.1 Wear Check of Pads and Brake Discs	16
5.2 Adjuster Check.	23
5.3 Caliper Check.	26
5.4 Clearance Measurement Check of Bearing Variants (6).	27
5.5 Sealing Elements Check	28
6. Brake Pad Replacement.	29
6.1 Removal of standard Brake Pads (without APR®-System)	29
6.2 Fitting of Standard Brake Pads (without APR®-System).	30
6.3 Removal of Brake Pads (with APR®-System).	32
6.4 Fitting of Brake Pads (with APR®-System)	33
6.5 Fitting Pad Wear Indicators (without APR sytem)	36
7. Tappet and Boot Assemblies (13) and Inner Seals (22) Replacement	39
7.1 Removal of Tappet and Boot Assemblies (13)	40
7.2 Replacement of Inner Seals (22)	42
7.3 Fitting of Tappet and Boot Assemblies (13).	44
8. Caliper Replacement.	47
8.1 Removal of Caliper from Carrier	47
8.2 Fitting Caliper to Carrier - (Carrier assembled on vehicle)	49

9. Caliper Bearings Replacement.	53
9.1 Removal of Inner Boot (9)	53
9.2 Replacement of Brass Bush (7a or 7b) Fixed Bearing	53
9.3 Replacement of Guide Sleeve Variant (6a, 6b, 6c, 6d, 6e or 6f) Floating Bearing	56
9.3.1 Removal of Guide Sleeve (6a, or 6b) Floating Bearing	57
9.3.2 Removal of Guide Sleeve (6c and 6e; Guide Sleeve) Floating Bearing	57
9.3.3 Removal of Guide Sleeve (6d Capped Rubber Sleeve)	58
9.3.4 Removal of Double Roll Bearing (6f)	58
9.3.5 Fitting of Guide Sleeve (6a Rubber Bush or 6b Open Bearing) Floating Bearing.	60
9.3.6 Fitting of Guide Sleeve (6c or 6e)	61
9.3.7 Fitting of Guide Sleeve (6d - Capped Rubber Sleeve)	62
9.3.8 Fitting of Double Roll Bearing (6f)	63
9.4 Fitting of Inner Boot (9a or 9b) Fixed Bearing or (9c, 9d, or 9e) Floating Bearing	65
9.5 Fitting of Guide Pin (5a or 5b) - Fixed Bearing	66
9.6 Fitting of Guide Pin (4a, 4b, 4c, 4d or 4e) Floating Bearing.	67
9.7 Engage Inner Boot (9) into Guide Pin (4c, 4d or 4e) Floating Bearing or (5a or 5b) Fixed Bearing	67
10. Carrier Replacement	69
11. Brake Actuator Replacement	70
11.1 Removal of Knorr-Bremse Brake Chamber.	70
11.2 Fitting of Knorr-Bremse Brake Chamber	70
11.3 Removal of Knorr-Bremse Spring Brake	71
11.4 Fitting of Knorr-Bremse Spring Brake.	72

1 Overview

1.1.1 Identification of the Guide and Seal Kit Variants

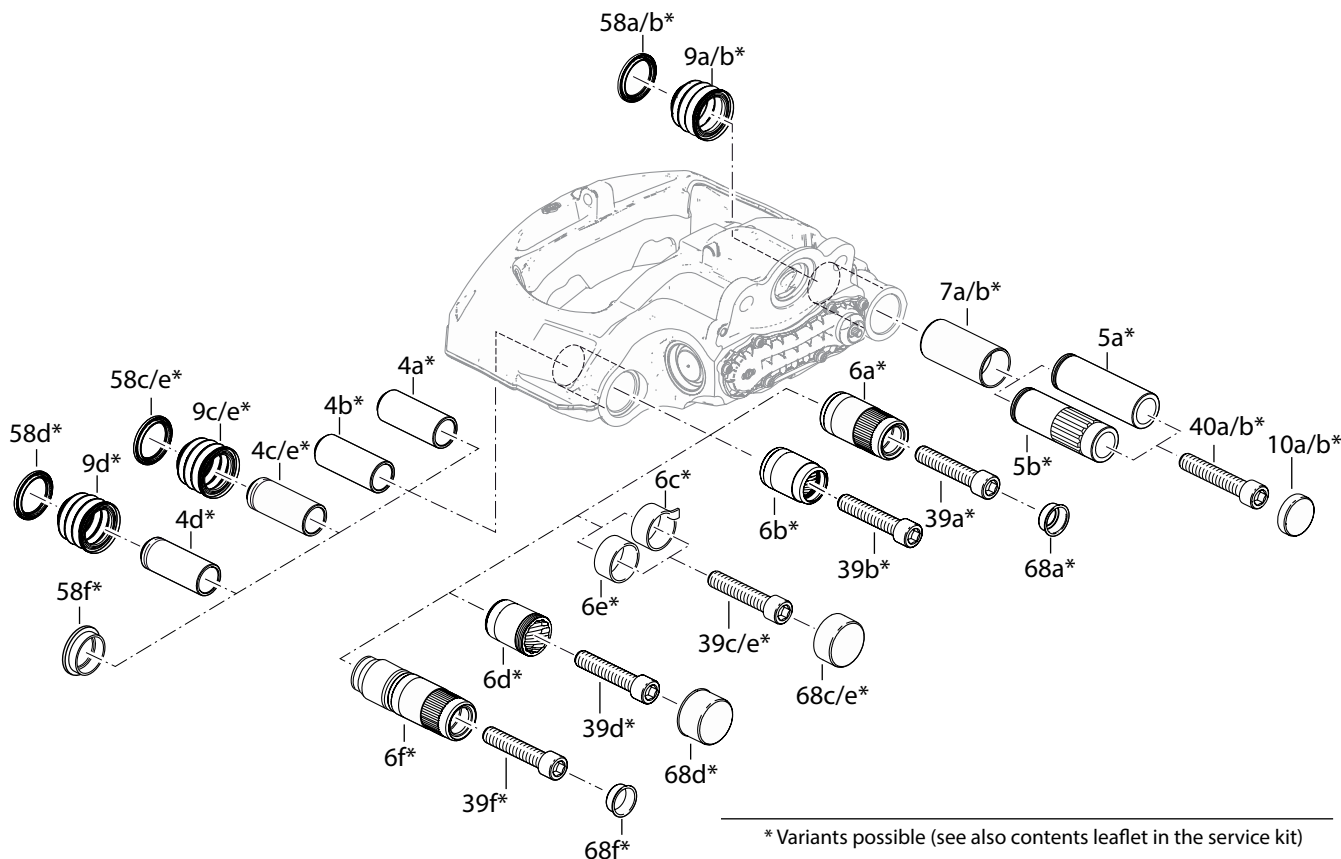

Floating Bearing (6) variants:



a) Rubber Bush

b) Open Bearing

c) and e) Guide Sleeve

d) Capped Rubber Sleeve

f) Double Roll Bearing

1 Overview

1.2 Brake Identification and Service Kits

- A** = Axle or vehicle manufacturer's identification number
- B** = Knorr-Bremse brake type number
- C** = Knorr-Bremse part number
- D** = Knorr-Bremse date of manufacture

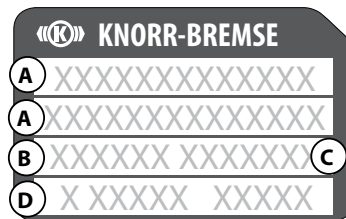
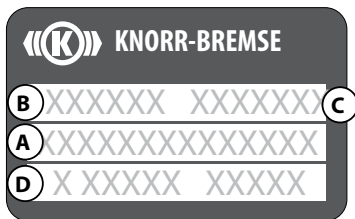
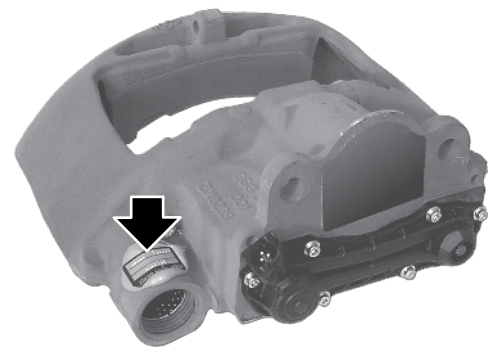

Use only genuine Knorr-Bremse parts!

The following service kits are available:

Description	Content	
Carrier	Carrier (2) 1x	
Guide and Seal Kit	Guide Pin (4a, 4b, 4c, 4d, 4e, 5a, 5b) Floating Bearing variants (6a, 6b, 6c, 6d, 6e, 6f) Brass Bush (7a, 7b) Inner Boot (9a, 9b, 9c, 9d, 9e) Cover (10a, 10b) Caliper Bolt (39a, 39b, 39c, 39d, 39e, 39f, 40a, 40b) Ring (58a, 58b, 58c, 58d, 58e, 58f) Cap (68a, 68c, 68d, 68e, 68f)	
Tappet and Boot Kit	Tappet and Boot (13) 2x Inner Seal (22) 2x Tappet Bush (161) 2x	For specific service part numbers allocated to the disc brake see: truckservices.knorr-bremse.com mytruckservices.knorr-bremse.com
Adjuster Cap	Adjuster Cap (37) 10x Shear Adapter (61) 10x	
Brake Pads (axle set)	Pad Retainer (11) 2x Brake Pad (12) 4x Spring Clip (26) 2x Adjuster Cap (37) 2x Pad Retainer Pin (44) 2x Washer (45) 2x Shear Adapter (61) 2x	
Caliper	Caliper (1) 1x Supplied without carrier (2) and without brake pads (12). Guide Pins and Seals kit included for assembly of caliper to existing brake carrier	Knorr-Bremse offers a range of specifically designed rationalised calipers to service a wide range of disc brakes. For specific caliper part number, see: truckservices.knorr-bremse.com mytruckservices.knorr-bremse.com

1 Overview

1.2.1 Wear Indicator Kits

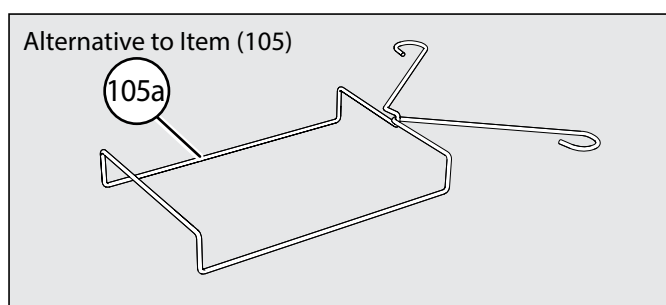
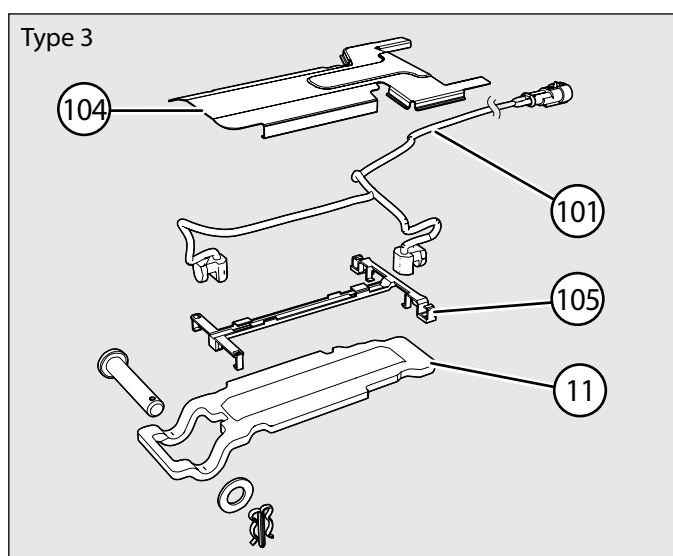
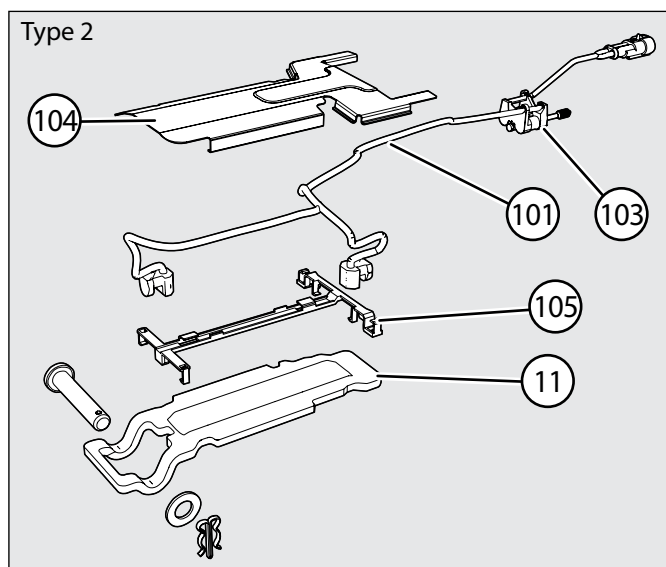
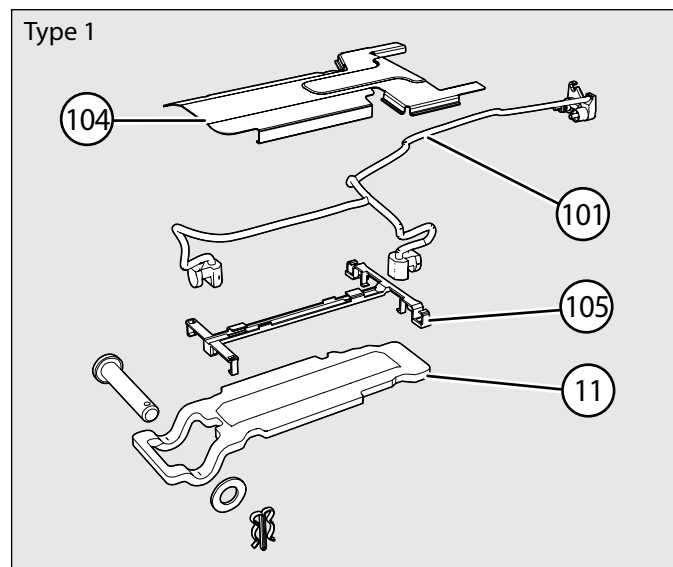

- 11 Pad Retainer*
- 101 Sensors with cable*
- 103 Cable to electrical supply*
- 104 Cable protection plate
- 105 Cable guide
- 105a Cable guide

* Variants possible

1.3 Brake Disc

Replacing brake discs is subject to the instructions of the vehicle or axle manufacturer, including when fitting Knorr-Bremse brake discs.



When replacing brake discs, make sure to use the correct connections and tightening torques.

The use of non-approved brake discs will reduce levels of safety, and will not be covered by any Knorr-Bremse liability.

Knorr-Bremse recommends the brake disc be changed as an axle set. Brake discs can be ordered through the Knorr-Bremse aftermarket organisation.

Additionally Knorr-Bremse recommends brake discs be changed at the latest every 6 years, even if the wear limits have not been reached.

2. General Information

-  The use of impact screwdrivers / impact wrenches in conjunction with Knorr-Bremse service tools for air disc brakes is not permitted. The service tools are not designed for such use.
-  Never turn the Adjuster (23) without Shear Adapter (61). If the given shear point of the Shear Adapter (61) is reached, the adapter will fail. Try again using a brand new shear adapter. If the adapter fails a second time, the whole caliper will need replacing due to internal damage. Do not use an open-ended spanner on the adapter as this could damage it.
-  Attention: Risk of injury. Knorr-Bremse accepts no liability for damage or injury resulting from negligence; any damage to service tools resulting from such actions will void all warranty.

2.1 Service Tools

Tool	Description	Consisting of tool components:
(A)	Wedged fork for removal of tappet and boot assembly (13)	TB03
(B)	Pull-in tool for tappet and boot assembly (13)	TB02, TB07, TB09, TB10, TB11
(C)	Press-in tool for inner seal (22)	TB10, TB11, TB12
(D)	Pull-in tool for inner boot (9)	TB01, TB04, TB17, TB18, TB19, TB25
(E)	Pull-out tool for brass bush (7)	TB01, TB04, TB17, TB18
(F)	Pull-in tool for brass bush (7)	TB01, TB17, TB18, TB19, TB24
(G)	Grooving tool for brass bush (7)	TB05
(H)	Pull-out tool for rubber bush (6a), open bearing (6b), guide sleeve (6c and 6e) and capped rubber sleeve (6d)	TB01, TB04, TB17, TB18
(K)	Pull-in tool for rubber bush (6a) and open bearing (6b)	TB01, TB16, TB17, TB18, TB21
(L)	Pull-in tool for guide sleeve (6c , 6e)	TB01, TB16, TB17, TB18, TB23, TB24
(M)	Pull-in tool for guide sleeve (6d)	TB01, TB17, TB18, TB19, TB21, TB24
(N)	Press-in tool for Cover (10)	TB20
(O)	Press-in tool for Cap (68a)	TB06, TB14
(P)	Press-in tool for Cap (68c und 68e)	TB20, TB22,
(R)	Press-in tool for Cap (68d)	TB06, TB13
(U)	Pull-in/Pull-out tool for double roll bearing (6f)	TB17, TSY01, TSY02, TSY04, TSY06, TSY07, TSY10

Note: The current service tool kit (Part No. K039062K50) contains the above listed tool components for tools (A) to (R). The supplementary tool kit K209211K50 contains the above listed tool components for tool (U).

2.2 Diagnostic Equipment

Part No.	Description
K154433N50	A Knorr-Bremse hand-held device for checking potentiometer function (see also Service News Y123889).

2.3 Lubricant

Part No.	Quantity	Colour	Application
II14525	5g	White	5.2; 7.2; 8.2; 9.2; 9.3; 9.5; 11
K093430	10g	White	5.2; 7.2; 8.2; 9.2; 9.3; 9.5; 11
II32868	500g	White	5.2; 7.2; 8.2; 9.2; 9.3; 9.5; 11
K125122N50	1000g	White	6.2

2.4 Torque Requirements

Item No.	Description	Torque	Spanner Size (mm)
39; 40	Caliper bolts (2x) M16x1.5 (hexagon socket head)	180 Nm plus 90°	14 (Hexagon key)
18	Brake chamber or spring brake	Follow the instructions of the brake actuator or vehicle manufacturer	-

3. Description and Function

3.1 Disc Brake Sectioned View

Legend

- 1 Caliper*
- 2 Carrier*
- 4 Guide Pin*
- 5 Guide Pin*
- 6 Rubber Bush / Guide Sleeve (floating bearing side)*
- 7 Brass Bush (fixed bearing side)*
- 9 Inner Boot*
- 10 Cover*
- 11 Pad Retainer*
- 12¹ Pad (inboard)*
- 12² Pad (outboard)*
- 13 Tappet and Boot Assembly
- 16 Threaded Tube
- 17 Bridge
- 18 Brake Actuator**
- 19 Lever
- 20 Eccentric Bearing
- 22 Inner Seal*
- 23 Adjuster Unit
- 24 Turning Device
- 26 Spring Clip
- 27 Spring
- 30 Chain
- 32 Chain Wheel
- 33 Wear Sensor
- 37 Adjuster Cap
- 39 Caliper Bolt*
- 40 Caliper Bolt*
- 44 Pad Retainer Pin
- 45 Washer
- 46 Disc
- 58 Ring*
- 61 Shear Adapter
- 68 Cover*
- 161 Tappet Bush

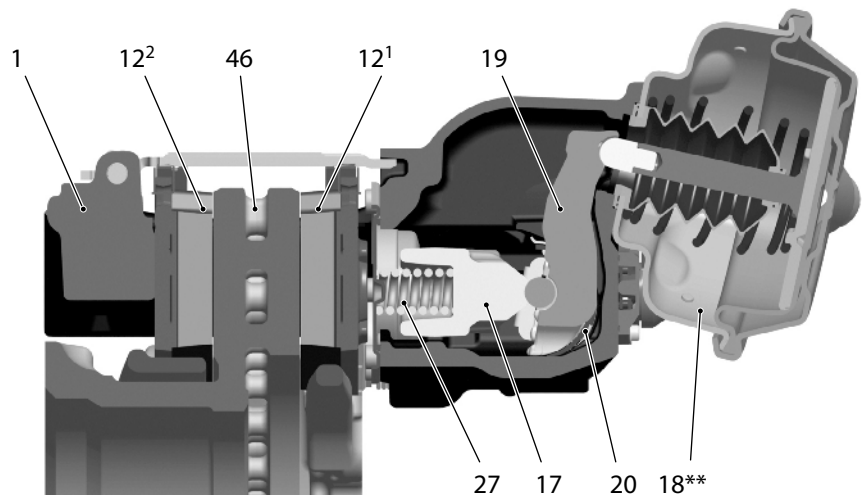
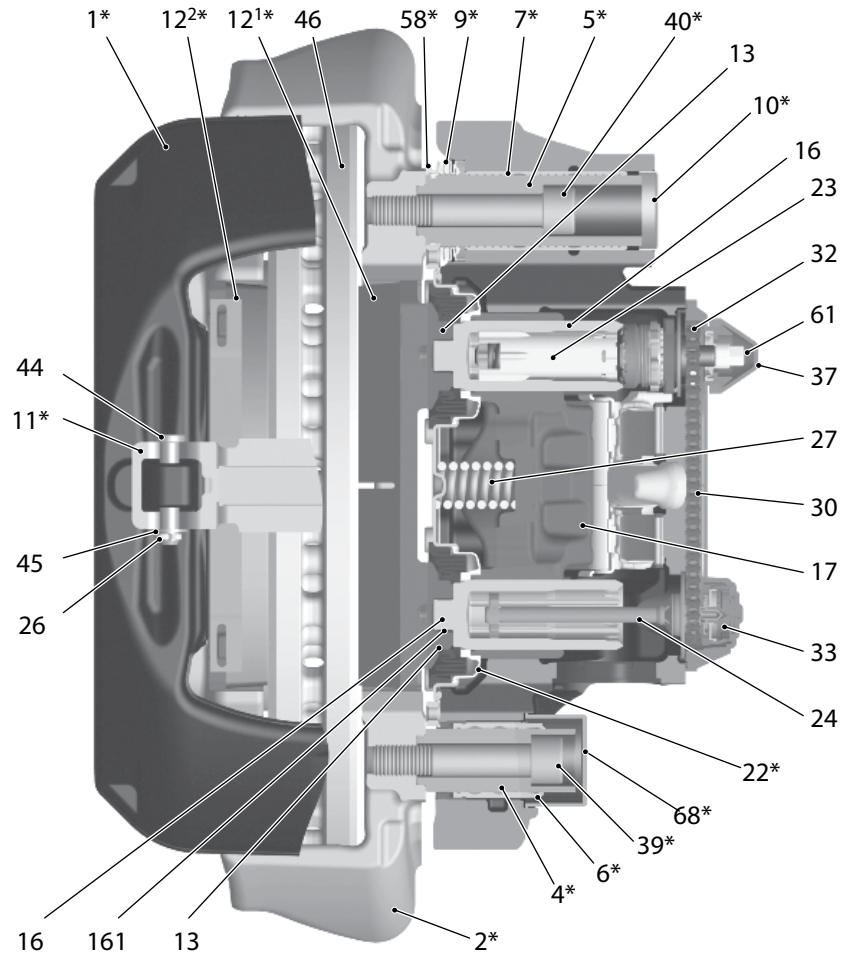

* variants
** Brake Chamber or Spring Brake

3 Description and Function

3.2 Description of Operation

(Floating caliper principle)

Brake Actuation

During actuation, the push rod of the actuator (18) moves the lever (19). The input forces are transferred via the eccentric roller bearing (20) to the bridge (17). The force is then distributed by the bridge (17) and the two threaded tubes (16) to the tappet and boot assemblies (13) and finally to the inboard pad (12¹).

After overcoming the running clearance between the inboard pad (12¹) and the brake disc (46), the reaction forces are transmitted by the caliper to the outboard pad (12²). The clamping forces on the pads and the disc (46) generate the braking force for the wheel.

Brake Release

After releasing the air pressure, the return spring (27) pushes the bridge (17) with the threaded tubes and lever (19) back to the start position.

Brake Adjustment

The so called running clearance of the disc brake is the air gap between the brake pad (12) and the brake disc (46). This distance is necessary to achieve a free running (and therefore unbraked) disc when the brakes are in a 'non applied' state. Too large a running clearance can lead to a greater braking distance.

The designated running clearance is so designed to compensate for changes under typical use such as:

- expansion of parts due to high temperatures.
- viscoelastic effect of the brake pads.
- finish and runout tolerances of a brake disc and possible lip development.

To ensure a constant running clearance between pads and disc, the brake is equipped with a non-wearing, automatic adjuster mechanism. The adjuster (23) operates with every cycle of actuation due to the mechanical connection with lever (19).

As the pads and disc wear, the running clearance increases. The adjuster (23) and turning device (24) turn the threaded tubes (16) by an amount necessary to compensate for this wear.

4. Inspection Points

Despite the use of long-life materials, it is necessary to check some of the components regularly for their general condition. The following inspection points will ensure a long-life and trouble-free operation of the disc brake.

Every 3 months

The pad wear must be checked visually and independent of any wear indicator fitted to the vehicle (see Sections 5.1).

With every pad replacement

It is important to check for the correct functioning of the adjuster (see Section 5.2) and the smooth operation of the caliper over its full range of movement (see Section 5.3). Also inspect the tappet and boot assemblies (13), the adjuster cap (37) and the sealing elements (9, 58) for correct fitting and condition as well as the caliper bearing in the area of the rubber bush/guide sleeve (6) (see Section 5.3.3).

Annually

Check the caliper running clearance (see Section 5.3.1) and the correct fitting and condition of the cover (10), the adjuster cap (37) and cover (68c, 68d or 68e) (depending on the bearing variant).

Note: These frequencies are a minimum and, depending on the vehicle application, a more frequent check of the components may be necessary.

Refer also to vehicle and/or axle manufacturer's instructions in regard to service intervals.

The discs should be checked according to the specification of the axle or vehicle manufacturer.

In the unlikely event of a problem, all relevant components must be returned in order that an objective investigation of the cause can be made.

For further information please refer to the Knorr-Bremse Dokument Y333409.

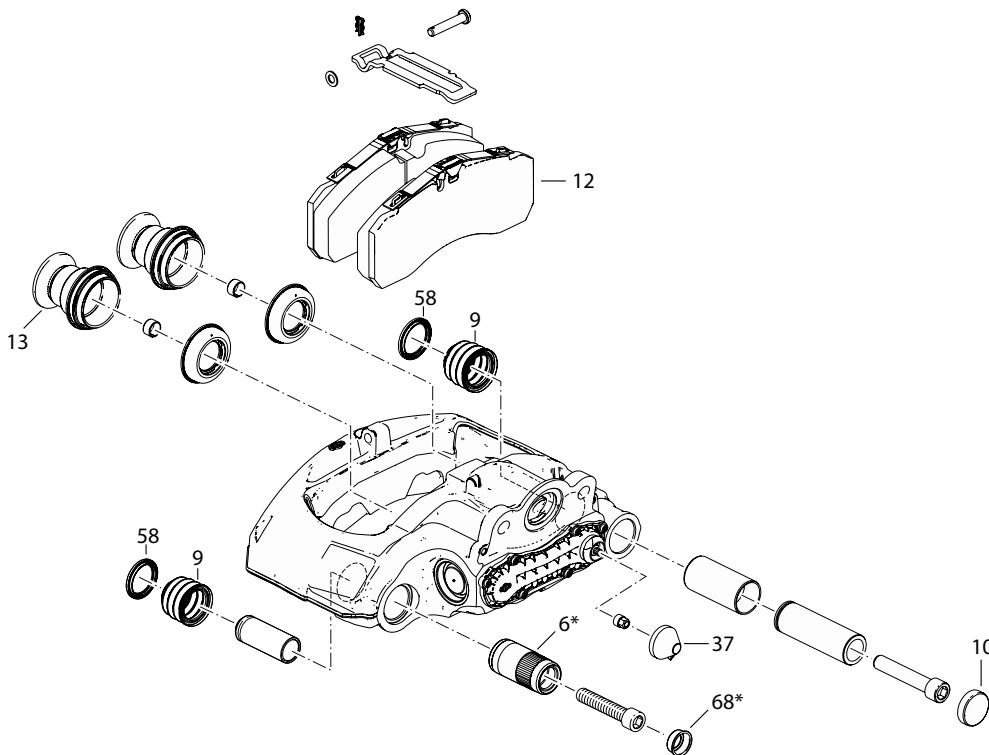

* Variants possible

4 Inspection Points

4.1 Safety Instructions for Service Work and Repair Work

Observe relevant safety instructions for service work and repair work on commercial vehicles, especially for jacking up and securing the vehicle.

Use only genuine Knorr-Bremse parts.

 Before starting service work, ensure the service brake and parking brake, as well as the bus stop temporary hold brake, if fitted, are not applied and that the vehicle cannot roll away.

Please follow service manual instructions and adhere to the wear limits of the pads and the discs (see Section 5.1).

Use only recommended tools (see Section 2.1).

Tighten bolts and nuts to the prescribed torque values (see Section 2.4).

 Screw threads and tapped holes must be free of lubrication and residuals of thread locking products.

After re-fitting a wheel according to the vehicle manufacturer's recommendations, ensure that there is sufficient clearance between the tyre inflation valve, the caliper and the wheel rim, to avoid damage to the valve and the wheel.

After any service work:

 Check the brake performance and the system behaviour on a roller dynamometer. Check function and effectiveness. Bear in mind that a lower performance can appear during the breaking-in phase of the brake pads and/or the brake disc.

Observe the "**Safety and Environment Guidelines**" section on pages 2 and 3.

5. Functional and Visual Check

5.1 Wear Check of Pads and Brake Discs

 For optimum safety, the pad and disc wear limits must not be exceeded.

Brake Pads

The thickness of the pads must be checked regularly dependent on the usage of the vehicle. The pads should be checked corresponding to any legal requirements that may apply. Even if a wear indicator is fitted and connected, this must be at least every 3 months.

5.1.1 Minor breakouts at the edges are permitted (see arrow).

5.1.2 Major breakouts on the surface of the brake pad are not permitted (see Fig.).

5.1.3 If the thickness of the friction material at its thinnest point is less than **2 mm** (dimension **C**) the pads must be replaced (see Fig.).

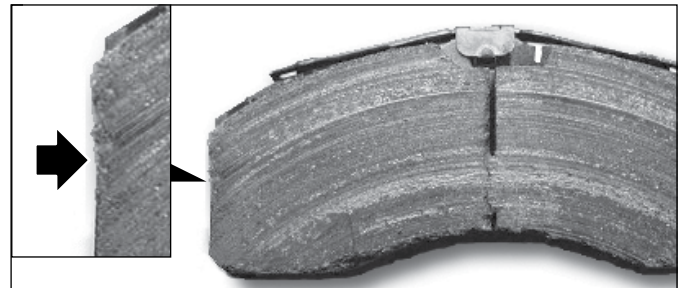

5.1.1 - Brake pad with minor damage (permitted)

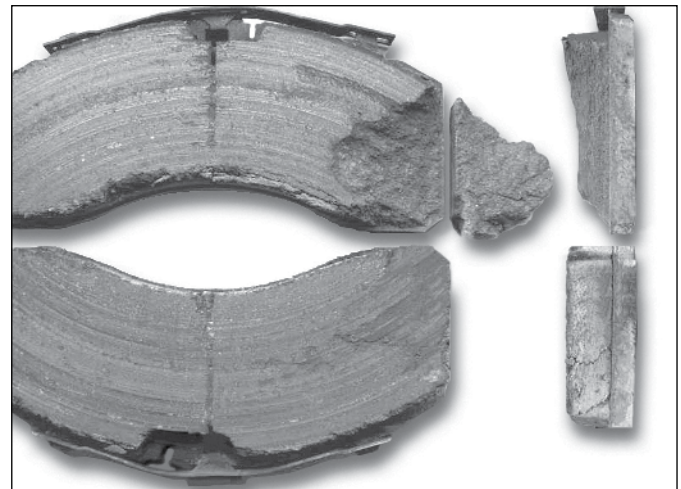

5.1.2 - Brake pad with major damage (not permitted)

A = Overall thickness of new brake pad **30 mm**

B = Backplate **9 mm** with SN6 and SN7 Backplate **7 mm** (middle) - **9mm** (outer edge) with SK7

C = Minimum thickness of friction material **2 mm***

D = Minimum allowed thickness in worn condition for backplate and friction material:

- With a **9 mm** backplate **D = 11 mm***
- With a **7 mm** backplate **D = 9 mm***

*If these minimum allowed thicknesses are reached, brake pads must be replaced as an axle set.

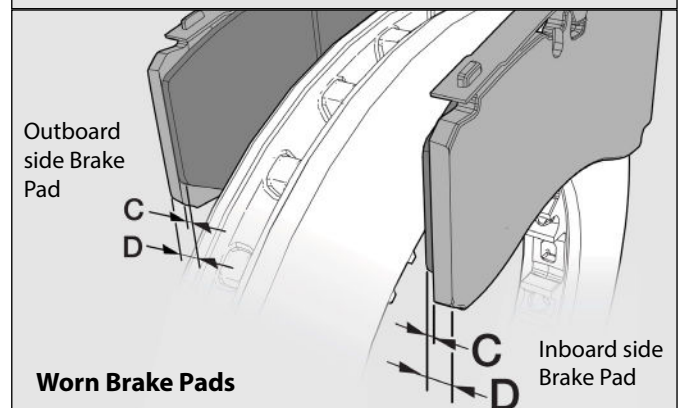
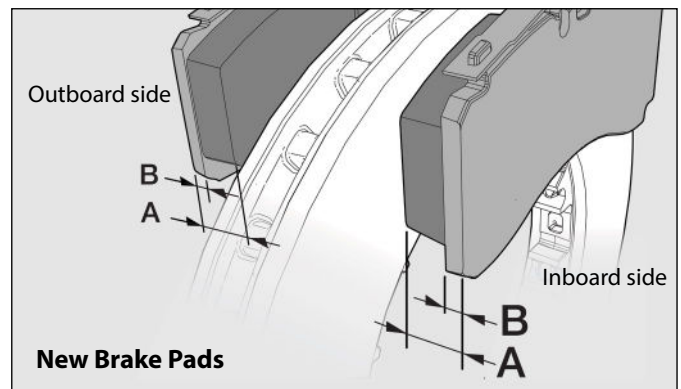

5.1.3 - Brake pad thicknesses

5 Functional and Visual Check

Exaggerated wear difference between inner and outer brake pads

5.1.4 The total thickness of the friction material of the inner and outer pad should be equal. If the difference between the two pads is greater than **3.5 mm** (see Fig.), then the following checks are necessary:

- Bearing clearance check (see Section. 5.3 and 5.4)
- Free movement of the brake pads in the caliper (see Section. 5.2)
- Possible collision with other parts on the axle or vehicle body
- Excessive dirt and grime present, if necessary contact the vehicle manufacturer
- piping of the compressed air line

Example:

- a) E = 19 mm
F = 15 mm > **NOT OK**
- b) E = 11,5 mm
F = 13 mm > **OK**

Exaggerated tangential oblique wear of brake pads

5.1.5 The total thickness of the friction material at either end of the pad should be equal. If the difference between the two ends is greater than **2 mm** (see Fig.), then the following checks are necessary:

- Bearing clearance check (see Section. 5.3 and 5.4)
- Free movement of the brake pads in the caliper (see Section. 5.2)
- Possible collision with other parts on the axle or vehicle body
- Excessive dirt and grime present, if necessary contact the vehicle manufacturer
- Piping of the compressed air line

In addition the brake pads must be replaced (see Section 6).

Example:

- c) G = 21 mm
H = 18 mm > **NOT OK**
- d) G = 18 mm
H = 19 mm > **OK**

Exaggerated taper wear of brake pads

5.1.6 The total thickness of the friction material in the radial direction should be equal. If the difference between the top and bottom ends is greater than **1 mm**, then the following checks are necessary:

- Bearing clearance check (see Section. 5.3 and 5.4)
- Free movement of the brake pads in the caliper (see Section. 5.2)
- Possible collision with other parts on the axle or vehicle body
- Excessive dirt and grime present, if necessary contact the vehicle manufacturer

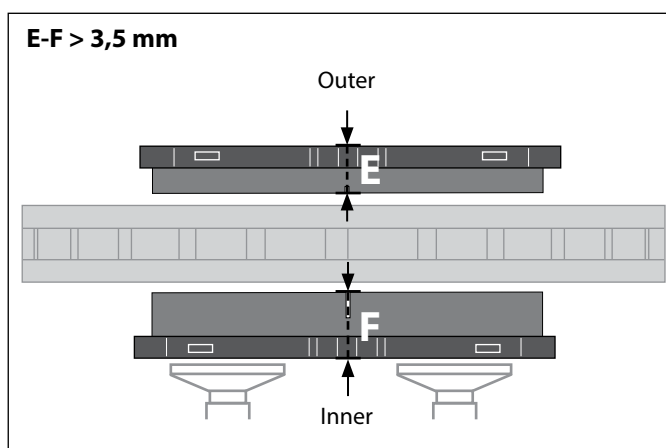

5.1.4 - Exaggerated wear difference between inner and outer brake pads

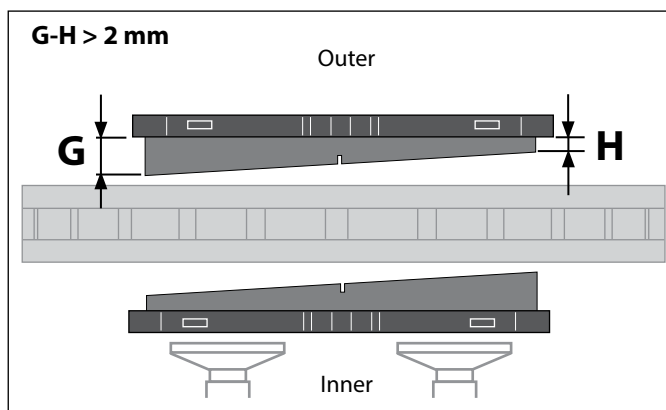

5.1.5 - Exaggerated tangential oblique wear of brake pads

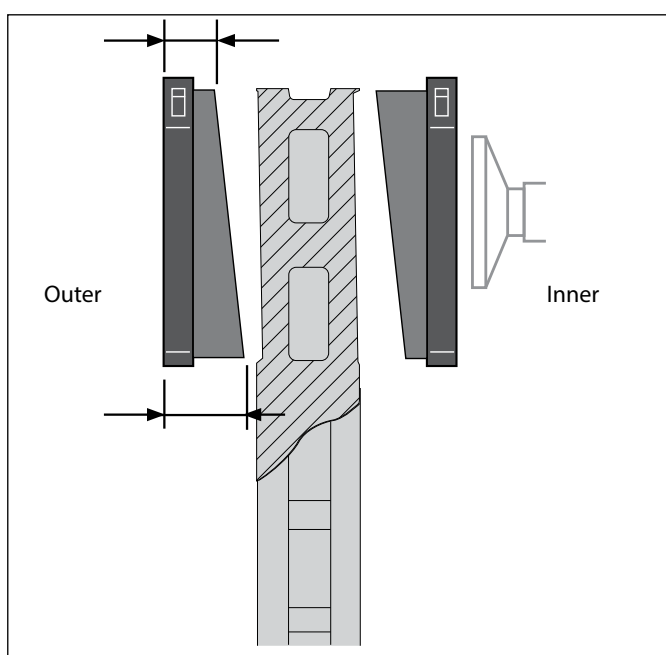

5.1.6 - Brake pad with exaggerated taper wear

5 Functional and Visual Check

Brake Disc

5.1.7 Measure the thickness of the brake disc at the thinnest point. Be aware of possible burring at the edge of the disc.

M = Total thickness of the brake disc:

New condition = **45 mm***.

Worn condition = **37 mm** or **N = 0 mm**- the disc must be replaced.

If the disc dimension **M ≤ 39 mm** or **N ≤ 1 mm**, it is recommended that all brake discs on the same axle be renewed when the brake pads are changed.

* Variants possible

Brake discs from Knorr-Bremse have an optical wear indicator as a chamfer on the outer edge of the disc (N). Therefore the brake disc wear should be checked whenever the brake pads are checked (see Fig.).



If these recommendations are ignored, there is a danger of brake failure and therefore increased safety risk.

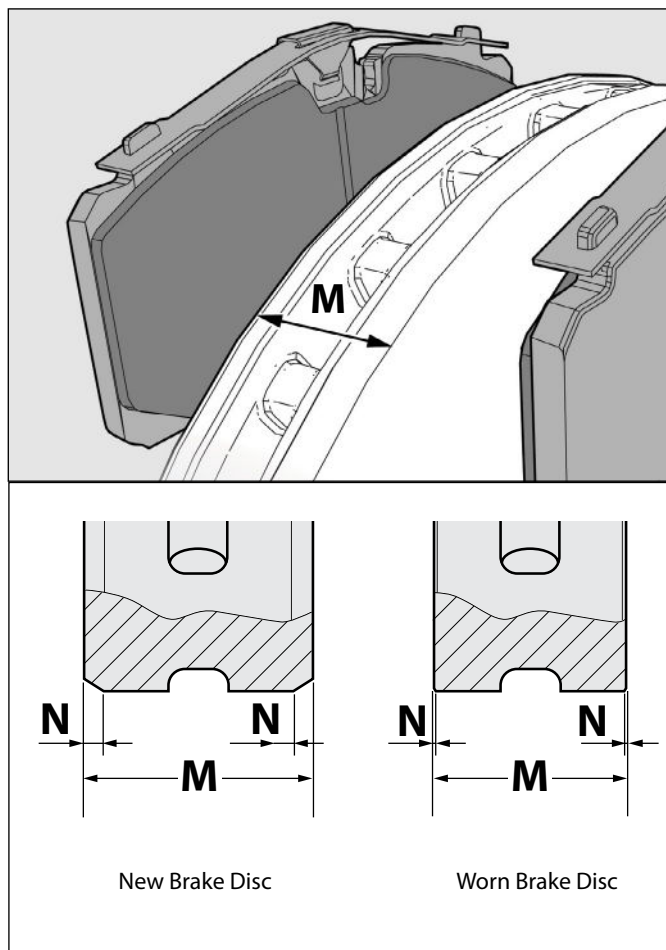

5.1.7 - Brake disc thicknesses and optical wear indicator

5 Functional and Visual Check

5.1.8 Check the discs per axle at each change of pads for grooves and cracks. If necessary replace the disc.

The figure shows possible surface conditions of the brake disc.

A₁ = Small cracks spread over the surface are allowed

B₁ = Cracks less than **1.5 mm** deep or wide, running in a radial direction are allowed
Cracks to a max. length of $0.75 \times a'$ are allowed
(**a** = width of the friction ring)

C₁ = Unevenness of the disc surface less than **1.5 mm** deep is allowed

D₁ = Cracks going through to the cooling duct or onto the inner or to the outer edge of the friction ring are not allowed and the disc **MUST BE REPLACED**

The photograph shows a real-life example of such cracks and wear grooves.

Note:

In case of surface conditions **A₁**, **B₁** or **C₁**, the disc can continue to be used until the minimum thickness **M = 37 mm** is reached.

Knorr-Bremse discs are normally service-free and grinding when changing pads is not necessary. However, grinding could be useful, e.g. to increase the load-bearing surface of the pads after severe grooving on the entire friction surface has occurred. To meet safety requirements, the minimum thickness after machining must be greater than **39 mm**.

In addition, the recommendations of the vehicle manufacturer about the machining of the brake disc **MUST** be followed.

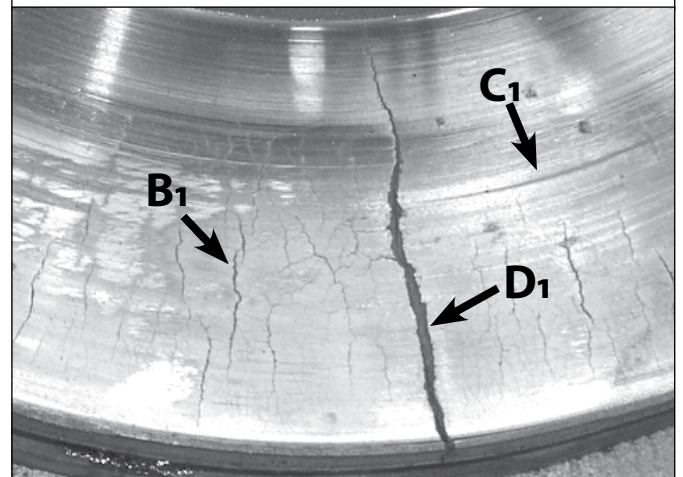
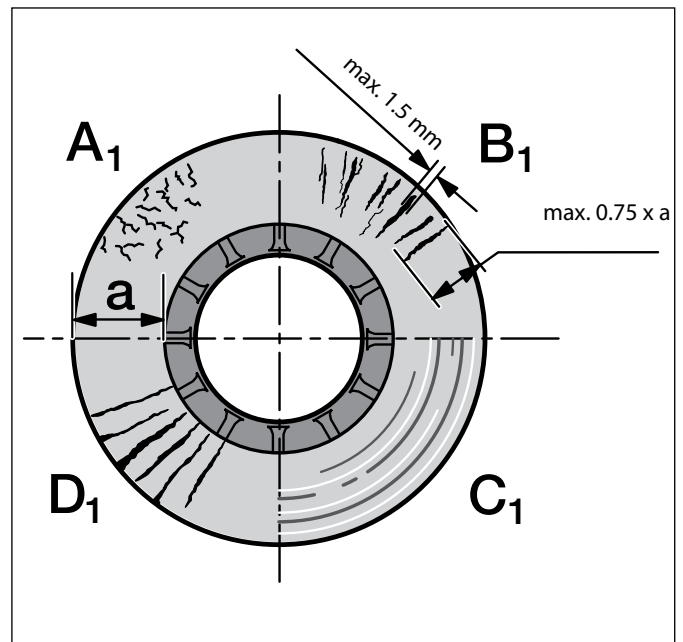

5.1.8 - Tolerances and examples of cracks and grooves on a brake disc.

 Grinding of a Knorr-Bremse Splined Disc® is not allowed.

 If these recommendations are ignored, there is a risk of an accident. If the brake pads and/or the brake disc are worn down excessively, brake performance will be reduced and may be lost completely.

5 Functional and Visual Check

Brake Pad/Disc Wear Check (on vehicle) with bearing variant (6a; Rubber Bush and 6f; Double Roll Bearing)

For all disc brakes equipped with rubber bush type (6a/6f) with axial ribbing (see arrow **H**).

5.1.9 The pads/disc wear can be visually determined without removing the wheel, by noting the position of the wear marker point (see arrow **G** - the change-over point from the ribbed to the smooth surface) (see Figs.).

If dimension **C** is less than **1 mm** (see Fig. 5.1.9b), the brake pad thickness and brake disc must be checked with the wheel removed. Depending on operating conditions, it may be necessary to check brake pad thickness and brake disc even when dimension **C** is greater than **1 mm**.

If any minimal tolerance limits have been reached (see Section 5.1) the pads and/or disc must be changed.

 Pads must be changed as an axle set (see Section 6). For disc replacement, follow vehicle manufacturer's recommendations.

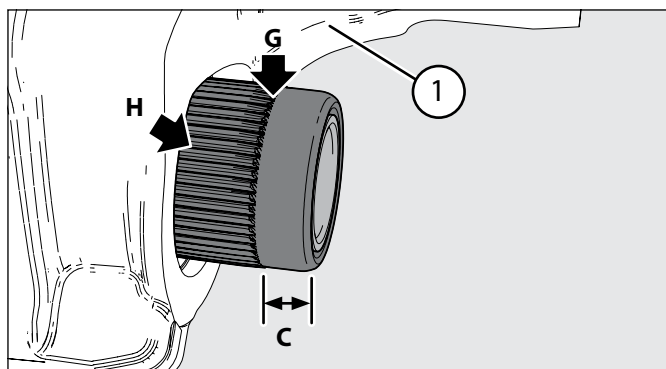

5.1.9a - Dimension **C** with new disc and brake pads

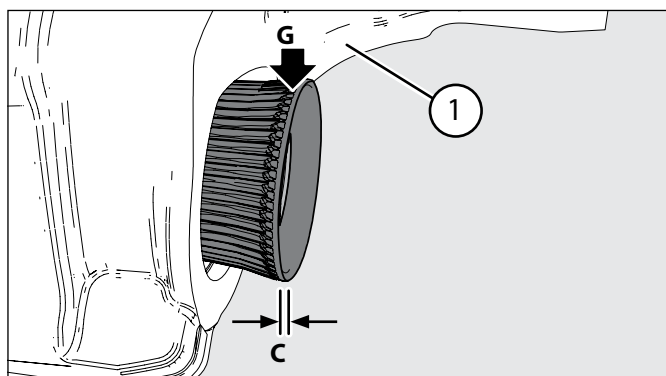

5.1.9b - Dimension **C** - requires inspection of pad and discs with wheel removed

Brake Pad/Disc Wear Check (on vehicle) with bearing variant (6b; Open Bearing)

5.1.10 The pads/disc wear can be visually determined without removing the wheel by checking the position of the caliper (1) compared to the fixed guide pin (4) (see Fig. 5.1.10a).

If dimension **C** is less than **1 mm** (see Fig. 5.1.10b), the brake pad thickness and the brake disc must be checked with the wheel removed. Depending on operating conditions, it may be necessary to check brake pad thickness and brake disc even when dimension **C** is greater than **1 mm**.

If any minimal tolerance limits have been reached (see Section 5.1) the pads and/or disc must be changed.

 Brake Discs and Pads must be changed as an axle set (see Section 6).

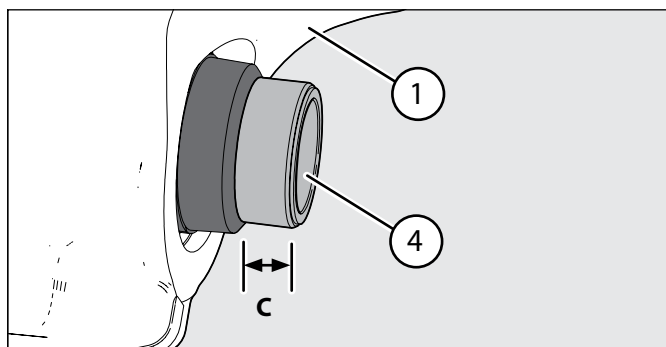

5.1.10a - Dimension **C** with new brake pads and disc

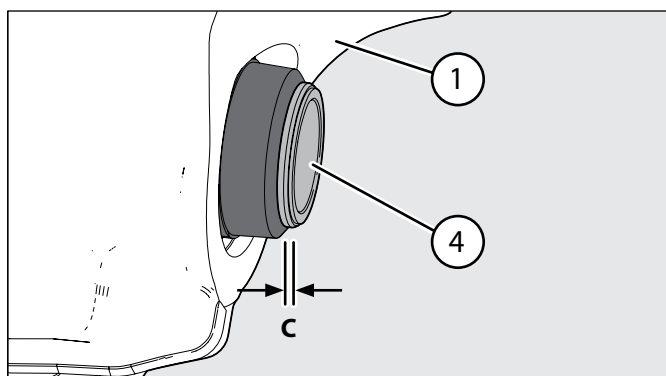

5.1.10b - Dimension **C** with worn disc/brake pads, to which it is a requirement to check pad and discs with wheel removed

5 Functional and Visual Check

1....
2....
3....

Brake Pad/Disc Wear Check (on vehicle) using Carrier to Caliper position with bearing variant (6c and 6e) Guide Sleeve and variant (6d) Capped Rubber Sleeve

For all disc brakes which are equipped with a caliper to carrier marking.

5.1.11 The pad/disc wear can be visually determined without removing the road wheel by viewing the position of the caliper position **P** compared to the carrier marking **R** (see Figs.).

If the positions of **P** and **R** are similar to those shown in 5.1.11b, the brake pad thickness and the brake disc must be checked with the wheel removed. Depending on operating conditions, it may be necessary to check brake pad thickness and brake disc even before these dimensions are reached.

If any minimal tolerance limits have been reached (see Section 5.1) the pads and/or disc must be changed.

 Brake Discs and Pads must be changed as an axle set (see Section 6).

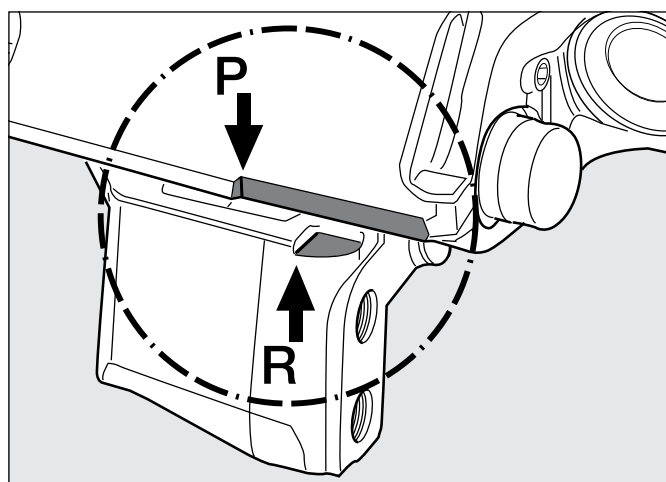

5.1.11 a - Position of points **P** and **R** with new brake pads and disc

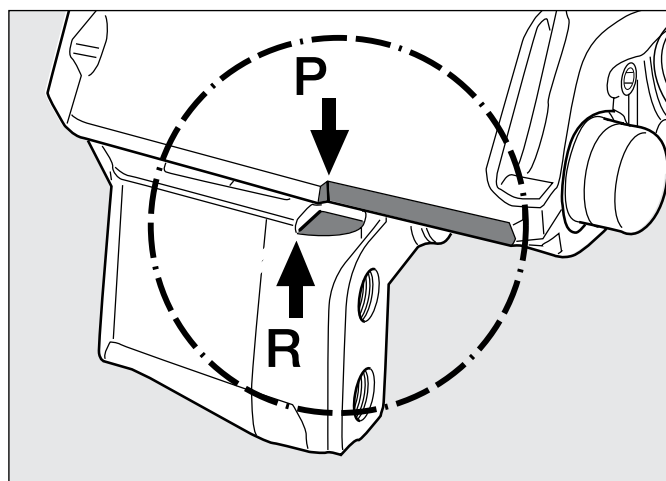

5.1.11 b - Position of points **P** and **R** requires inspection of pad and discs with wheel removed

5 Functional and Visual Check

Wear Indicators

5.1.12 Due to different vehicle manufacturers and vehicles there are several types of pad wear indicator used.

- In-pad normally **closed** indicator - circuit is broken when pad wear reaches limit (see Fig.).
- In-pad normally **open** indicator - circuit is made when pad wear reaches limit (see Fig.).
- Wear indicator using built-in potentiometer. This is available either as an on/off version or as a continuous signal version which can be linked to the vehicle's electronic monitoring systems (see Fig.).

Either acoustic or optical diagnostic units can be connected.

Note: Please also refer to specifications provided by the vehicle manufacturer.

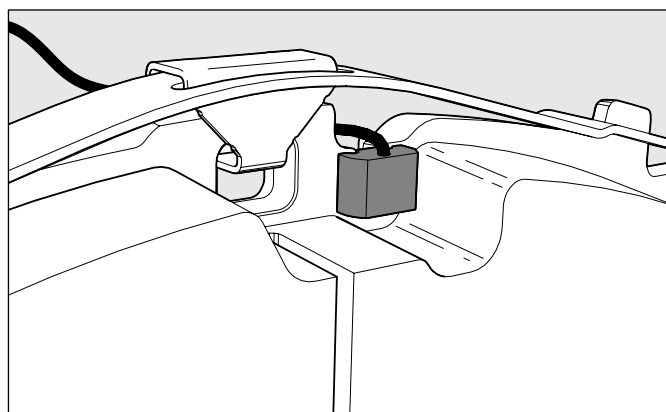

5.1.12a - 5.1.12b - In-pad wear Indicator

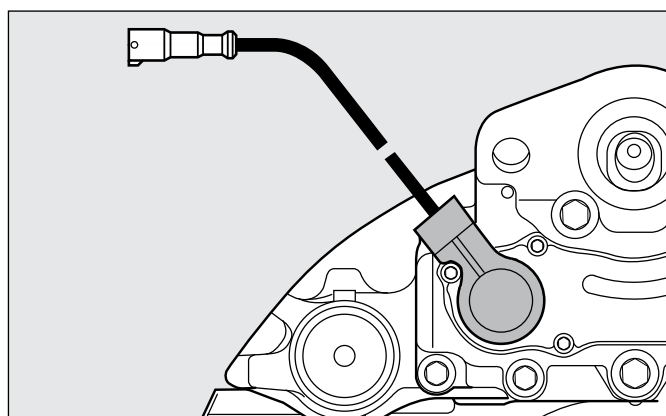

5.1.12c - Wear Indicator with built-in potentiometer

Knorr-Bremse diagnostic unit K154433N50

The Knorr-Bremse Potentiometer Tester serves;

- To test the Potentiometer function on Knorr-Bremse disc brakes
- To check the wear condition of the brake pads and brake discs

5.1.13 The Tester can be used on all current Knorr-Bremse brake types with continuous or black/white Potentiometer.

Note: Knorr-Bremse recommends that before replacing a brake caliper with a suspected potentiometer failure, that it first be tested using the Potentiometer Tester. If no defect is found, the cause is not with the brake caliper and therefore does not need replacing.



5.1.13 - Knorr-Bremse diagnostic unit K154433N50

5 Functional and Visual Check

5.2 Adjuster Check

5.2.1.1 Before starting work, ensure that the wheels are chocked and the vehicle cannot roll away.

5.2.1.2 Ensure that service brake and parking brake, as well as bus stop temporary hold brake, if fitted, are in the released condition.

5.2.1.3 Check the supply pressure of the brake system (should be > 6.5 bar). Connect an additional external supply to prevent pressure drop.

5.2.1.4 Jack up the axle and remove the wheel (refer to the respective vehicle /axle manufacturer's instructions).

5.2.1.5 Check the brake disc temperature, it should be between -10°C and 50°C .

5.2.2 Push and pull caliper three times in axial direction to assess any existing air gap (see Fig.). If no movement is possible, clean the brake and if necessary, replace the bearings (see Section 9). Once movement is obtained, continue as follows:

5.2.3 Pull off the adjuster cap (37) using the tag, taking care not to lose the shear adapter (61) (see Fig.).

 Removal of the adjuster cap (37) with a screwdriver, or similar, is not allowed since the seal may be damaged.

5.2.4 Insert new brake pads (see Section 6.2).

5.2.5 Set the starting gap by turning the adjuster (23) with the shear adapter (61) backwards and then forwards (note that when turning backwards a noticeable clicking can be heard and felt), until a value of **1.3 mm** air gap has been achieved (measure between the brake pad and Tappets (13)).

5.2.6 Apply the brakes **20x** with medium pressure (ca. 2-3 bar).

5.2.7 Check the gap between each of the tappets (13) and inboard pad backplate (12). This must be measured over the whole tappet surface of both tappets using two feeler gauges simultaneously (feeler gauges must be at least **220 mm** long) (see Fig.).

If the gap difference between the two tappets is > 0.25 mm then the caliper bearing clearance must be checked (see Section 5.3).

In addition each gap must measure between **0.6 - 1.2 mm**.

 If the clearance is too great, there is a danger of brake failure. If the clearance is too small, there is a danger of overheating that may lead to consequential damage.

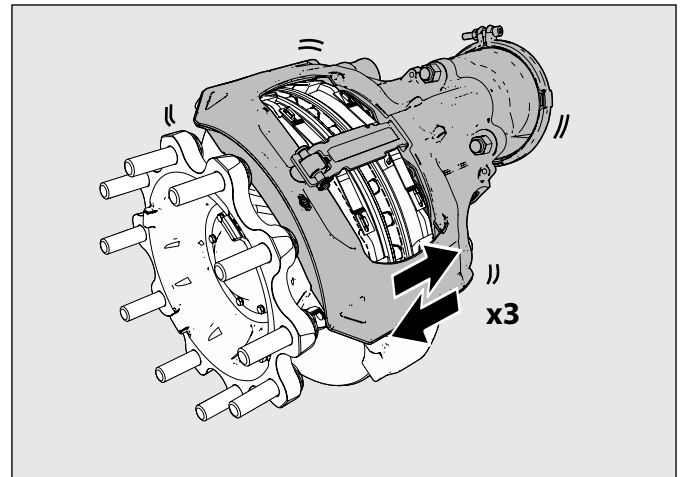

5.2.2 - Push caliper three times in axial direction

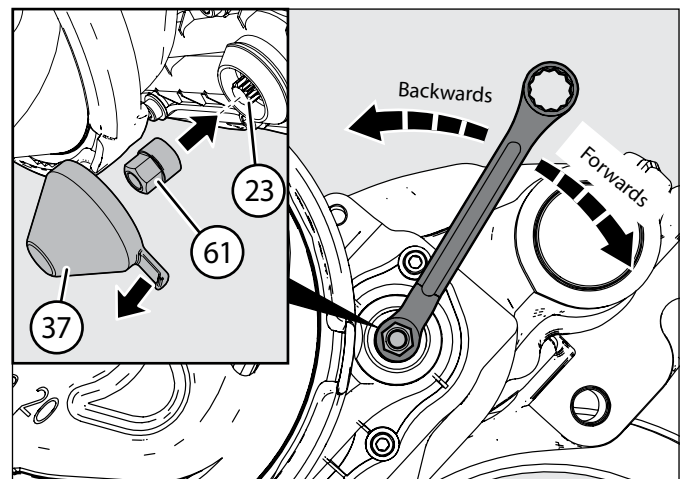

5.2.3 - 5.2.5 - Remove cap, insert new brake pads, set the starting gap

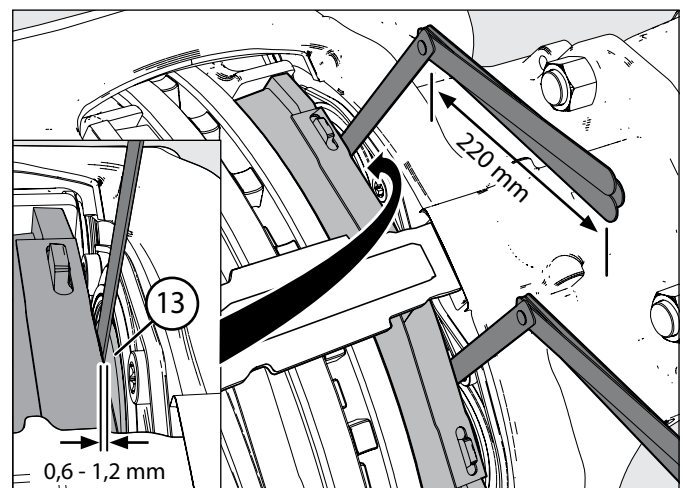

5.2.7 - Check gap between tappets and inboard pad

5 Functional and Visual Check

5.2.8 If the air gap is larger than 1.2 mm the adjuster must be checked as follows:

5.2.8.1 Turn the adjuster with adapter (61) **3 clicks** anti-clockwise (increasing the air gap) (see Fig.).

 Make sure the ring spanner or socket can turn freely clockwise during the following procedure.

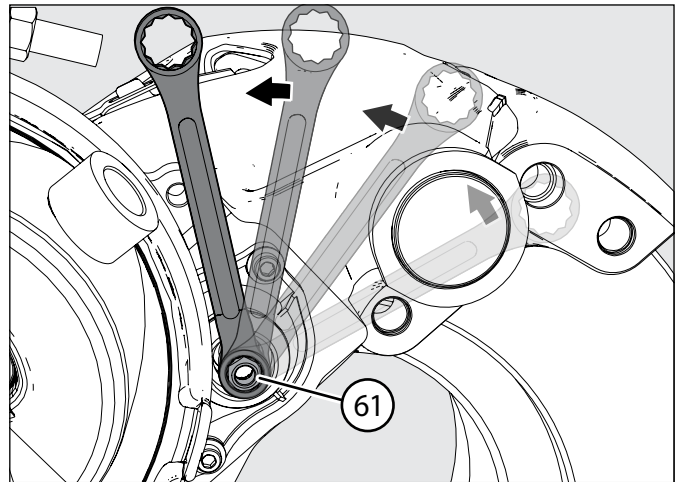

5.2.8.1 - Turn adapter 3 clicks anti-clockwise

5.2.8.2 As a visual aid, position a ring spanner or socket onto the adjuster (including Adapter (61)) as shown. Apply the brake **5 to 10 times** (ca. 2 bar), the spanner or socket should turn clockwise (viewed from actuator side) in small increments if the adapter is functioning correctly (see Fig. and note below).

Note: As the number of applications increases, incremental movement of the ring-spanner or socket will decrease. If the spanner or socket does not turn or turns only with the first application or turns forward and backward with every application, the automatic adjuster has failed and the caliper must be replaced.

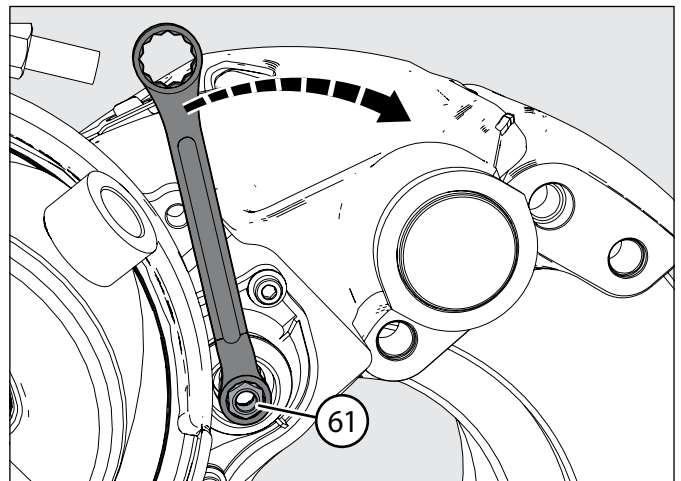

5.2.8.2 - Apply the brake 5-10 times, spanner turns clockwise

5.2.8.3 If necessary, clean the contact area of the cap. Lightly grease the contact surface of the cap with white grease (available as Part No. I114525, K093430 or I132868).

The tag of the adjuster cap (37) should be positioned as shown by the arrow in the adjacent figure. This ensures access is maintained for subsequent removal (see Fig.).

Note: A new adjuster cap (37) should be fitted even if the brake pads are not being replaced.

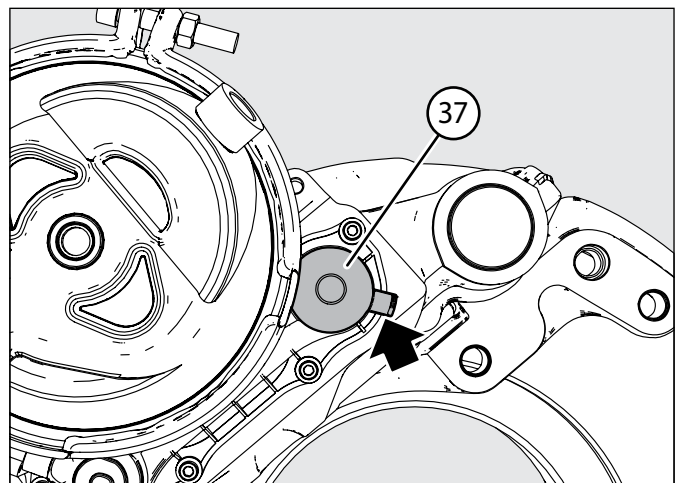

5.2.8.3 - Tag positioning of the cap

5 Functional and Visual Check

5.2.9 If the air gap is smaller than 0.6 mm the parameters and functions must be checked as follows:

5.2.9.1 Function of the brake actuator, refer to specifications provided by the manufacturer.

5.2.9.2 Remove brake actuator (18) (see section 11.1 and 11.3).

5.2.9.3 Check position of lever (19) inside the caliper in its released state (see arrow).

5.2.9.4 Remove brake pads (12) (see section 6.1). If necessary, remove dirt from brake pads, caliper and carrier.

- Check brake pads for wear from the tappets and if necessary replace brake pads.
- Check for abnormal wear of the contact areas of the carrier. If necessary replace the carrier.

5.2.9.5 Check the brake disc. For Knorr-Bremse brake discs see section 5.1. For other manufacturers refer to their specifications.

5.2.9.6 Check caliper running clearance (see Section 5.3.).

5.2.9.7 Fit the brake pads (see Section 6.2).

5.2.9.8 Fit the brake actuator (see Section 11.2 or 11.4.).

5.2.9.9 Recheck the adjuster (see Section 5.2.6.).

If the air gap is still smaller than **0.6 mm** between both tappets, the brake caliper must be replaced.

5.2.10 Refit the wheel according to the vehicle manufacturers specifications.

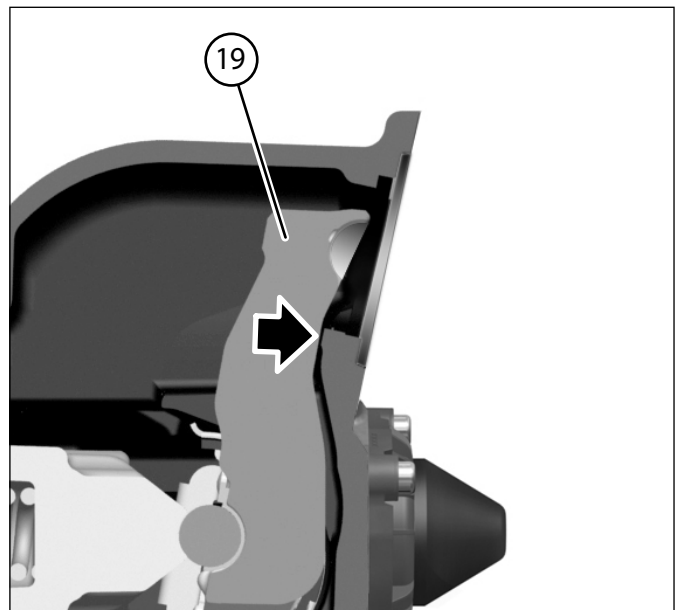

5.2.9.3 - Check lever position

5 Functional and Visual Check

5.3 Caliper Check Caliper Running Clearance

⚠ Before starting work, ensure that the wheels are chocked and the vehicle cannot roll away.
Ensure that service brake and parking brake, as well as the bus stop temporary hold brake, if fitted, are in the released condition.

5.3.1 By pushing and pulling the caliper in an axial direction by hand, a movement within the running clearance (see Section 5.2) must be possible (see Fig.).

If, even using a high level of hand pressure (no tools), the caliper is not moveable the caliper guide pin seals must be examined (see Section 5.5).

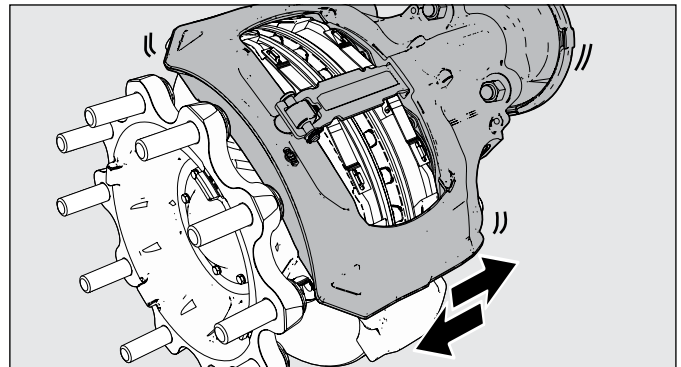

5.3.1 - Push and pull hand test

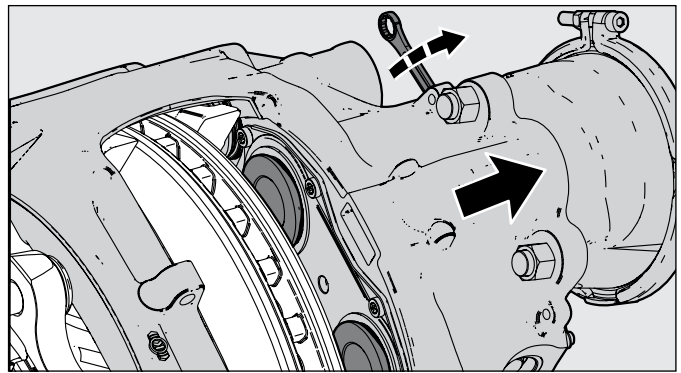

5.3.5 - 5.3.6 - Rewind tappets completely and push caliper in direction of middle of vehicle

Caliper Movement along Guide Pins

5.3.2 With the open bearing variant (6b), if necessary clean the protruding area of the guide pin (4b) from outside of the caliper and remove any light corrosion using an emery cloth.

5.3.3 Lightly apply grease (order No. II14525, K093430 or II32868) to the protruding area of the guide pin (4b).

5.3.4 Remove brake pads (see Section 6.1).

5.3.5 Fully wind back the tappets (13) using a ring spanner and shear adapter (61) (see Fig.).

5.3.6 Push caliper inboard towards vehicle's centre (see Fig.).

5.3.7 With both open bearing variants (6a and 6b), clean guide pin (4a or 4b) from the inner area of the caliper, removing any dirt or corrosion.

5.3.8 Lightly apply grease (order No. II14525, K093430 or II32868) to guide pin (4a or 4b).

5.3.9 Caliper (1) must slide freely along the whole length of the guide pin arrangement; movement should be greater than **25 mm**. (see Fig.).

If the caliper does not move at least **25 mm**, the caliper guide pin seals must be examined (see Section 5.5).

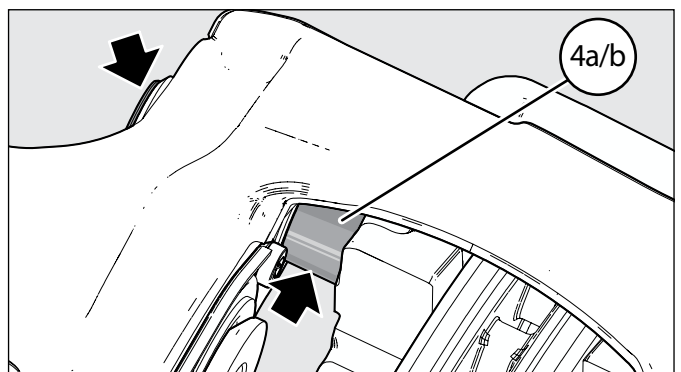

5.3.7 - Free guide pin of dirt

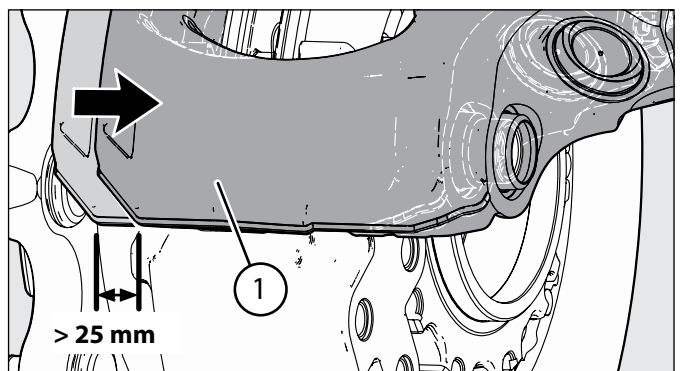

5.3.9 - Free movement of caliper > 25 mm

5 Functional and Visual Check

5.4 Clearance Measurement Check of Bearing Variants (6)

Note: Before commencing (removing the wheel), make sure there is no contact between caliper and axle, vehicle, chassis sections or carrier. In such cases it will be necessary to replace the caliper bearings (see Section 9).

To measure the clearance, the following steps must be taken:

5.4.1 Remove the wheel, refer to vehicle manufacturer's recommendations.

5.4.2 Remove pad retainer (11) (see Section 6.1.2).

To achieve the correct reading it is necessary to have a pair of new brake pads fitted. If the clearance measuring is not taking place during a brake pad replacement, the current position of the assembled pads must be noted before removing, so that they can be re-assembled in the same position.

Remove old pads (see Section 6) (at this point Section 5.1 "Wear Check of Pads and Brake Discs" must also be observed) and replace with a pair of new pads.

5.4.3 Fasten a magnetic dial-gauge holder to the carrier (2) on the floating bearing side of the caliper (1). Use the casting tag on the caliper (1) as the measuring point - see arrows **A** (see Fig.).

5.4.4 Set the dial-gauge to zero.

5.4.5 Place a suitable tool (e.g. screwdriver with at least **200 mm** in length) in a central position between carrier (2) and caliper (1) and lever them in opposite directions (using normal hand-force) (see Fig.).

5.4.6 Read the maximum value of the bearing clearance on the dial-gauge and compare with the values in the table (see Table).

If the clearance exceeds the given tolerance, the complete bearing will need replacing using the relative service kit (see Section. 1.2 and Section. 9).

If the clearance measuring is not taking place during a brake pad replacement, the new pads should be removed and the previously marked brake pads fitted in their original positions, otherwise renew the brake pads as an axle set and adjust the air gap (see Section 6.2).

5.4.7 Fit the wheel (refer to vehicle manufacturer's recommendations). After replacing the wheel check that it runs interference free.

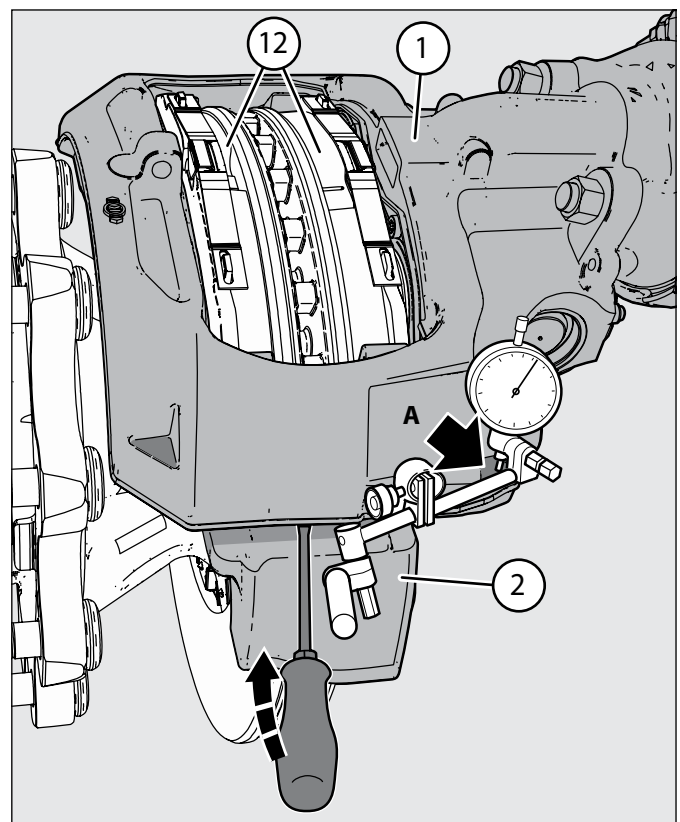

5.4.3 - 5.4.5 - Obtaining maximum value of bearing clearance

Bearing variants (6)	Max. bearing clearance
6a Rubber Bush	2 mm
6b Open Bearing	2 mm
6c Guide Sleeve	1 mm
6d Capped Rubber Sleeve	2 mm
6e Guide Sleeve	1 mm
6f Double Roll Bearing	2 mm

5.4.6 - Maximum bearing clearance tolerances of bearing variants

5 Functional and Visual Check

5.5 Sealing Elements Check

Caliper Guide Pin Seals

5.5.1 The guide pin (5a or 5b) (as fitted to the fixed bearing side) is sealed with cover (10a or 10b) and inner boot (9a or 9b) (see also Section 1.1.1).

The floating bearing side with guide pin (4c, 4d or 4e) is sealed with inner boot (9c, 9d or 9e) and with cover (68c, 68d or 68e). All variants (9), (10) and (68) must be free of any signs of damage (see Fig.).

Check for correct location and fitting.

If necessary, remove pads (12) to inspect the inner boots (9) (see section 6.1).

If necessary, repair caliper with suitable service kit (see Section 1.2 and Section 8).

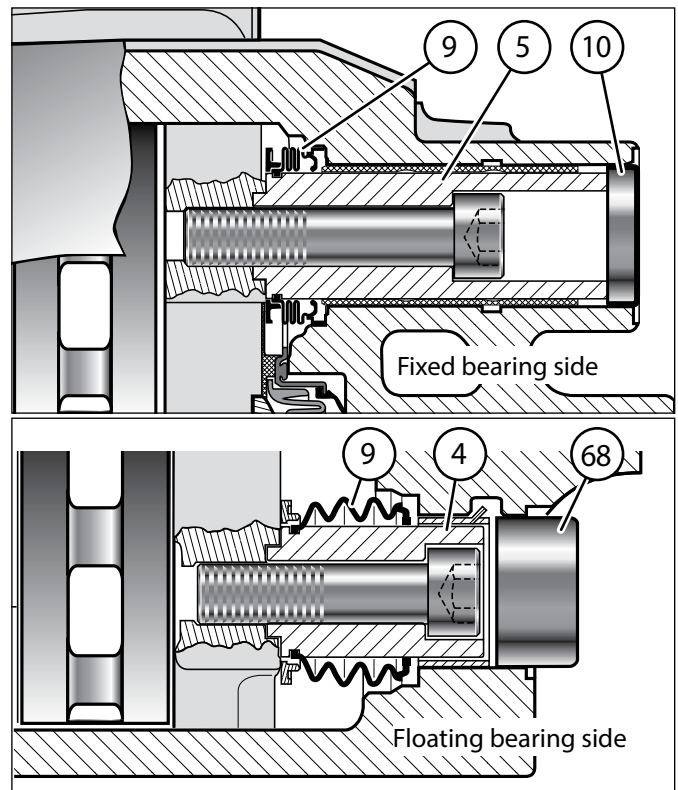

5.5.1 - Checking of guide pin and seals

Checking of Tappet and Boot Assemblies (13)

Remove pads (12) (see Section 6.1).

5.5.2 Screw out the tappets (13) using the shear adapter (61) clockwise until the boots are clearly visible (see Fig.).

 The tappets must not be extended more than **30 mm**, otherwise synchronisation is lost and the caliper must be replaced.

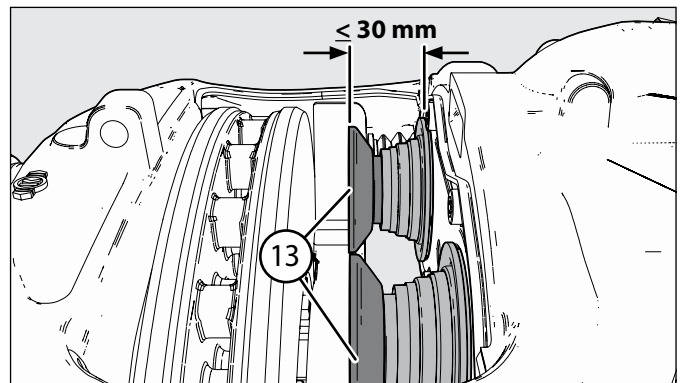

5.5.2 - Screw out tappets - max. 30 mm

5.5.3 The rubber boots on the tappets (13) must not have any cuts/tears or show any other signs of damage (see Fig.).

Check for correct location and fitting.

Note: The penetration of dirt and moisture into the brake will lead to corrosion and impair the function of the clamping mechanism and wear adjuster.

If necessary replace tappet and boot assemblies (see Section 7).

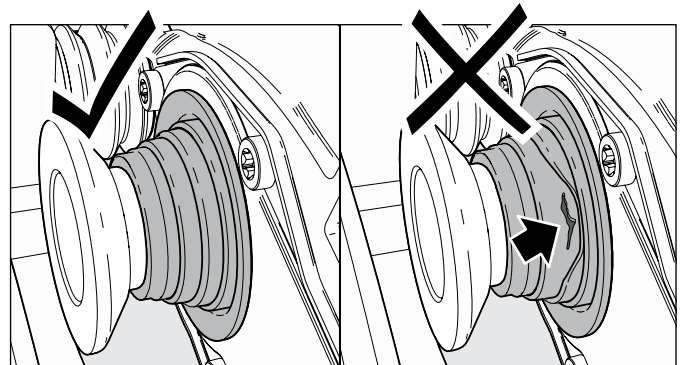

5.5.3 - Check rubber boots for damage

6. Brake Pad Replacement

! Before starting work, ensure that the wheels are chocked and the vehicle cannot roll away.
Ensure that service brake and parking brake, as well as bus stop temporary hold brake, if fitted, are in the released condition.

! During service work on vehicles with electronic parking brake, service or parking brake, or bus stop temporary hold brake, the brake system must be set to service and maintenance mode. Please also observe the instructions of the vehicle manufacturer.

6.1 Removal of standard Brake Pads (without APR®-System)

6.1.1 Remove wheel (refer to vehicle manufacturer's recommendations).

Important! Also be aware of the inspection points detailed in chapter 4, as well as checking the caliper free movement (see Section 5.3).

! Depending on the orientation of the caliper on the axle, brake pads could fall out when removing the pad retainer (11).

6.1.2 Remove spring clip (26) and washer (45), depress the pad retainer (11) and remove pin (44) (see Fig).

If necessary remove any in-pad wear sensor components (see Section 6.5).

6.1.3 Pull off the adjuster cap (37) using the tab, taking care not to lose the shear adapter (61) (see Fig. insert).

! Do not use any tools to remove the cap (37) as this can damage the sealing elements of the adjuster.

6.1.4 Fully wind back the tappet and boot assemblies (13) by rotating the adjuster (23) via the shear adapter (61) in an anti-clockwise direction (as viewed from actuator side) – a loud clicking noise is generated (see Fig).

6.1.5 Remove brake pads (12¹) and (12²) (see Fig).

Note: The geometry of the brake pad housing of **SK7** disc brakes require the following removal procedure of the brake pads (12):

- Pull caliper (1) towards the outboard side.
- Remove outer brake pad (12²)
- Push caliper (1) to the inboard side.
- Remove inboard brake pad (12¹)

6.1.6 Check caliper running clearance (see Section 5.3).

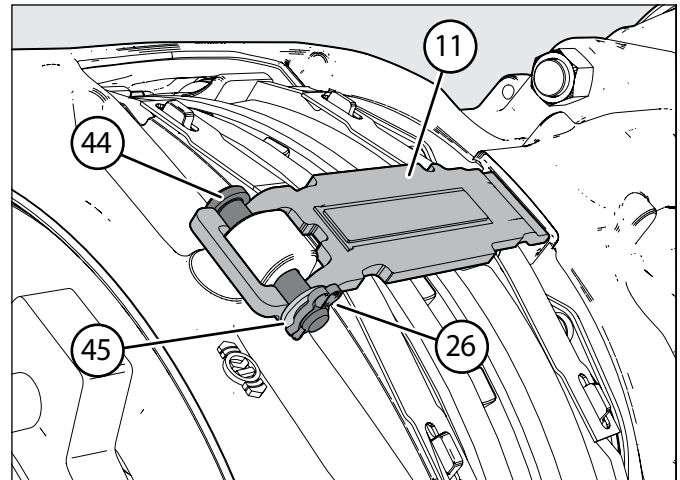

6.1.2 - Removing pad retainer

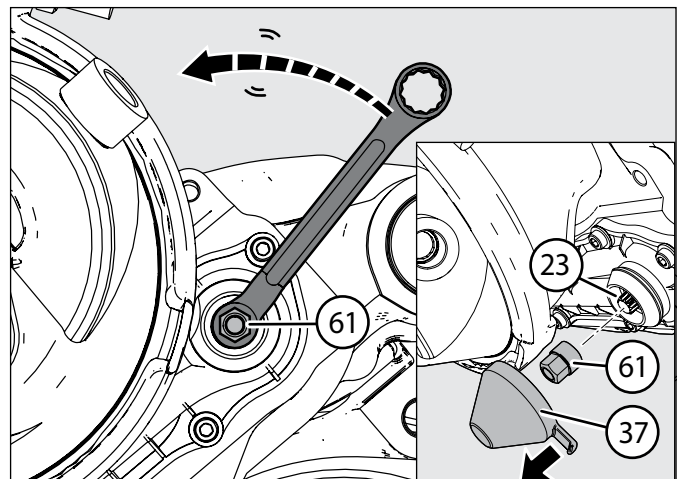

6.1.3 - 6.1.4 - Rewind adjuster using shear adapter

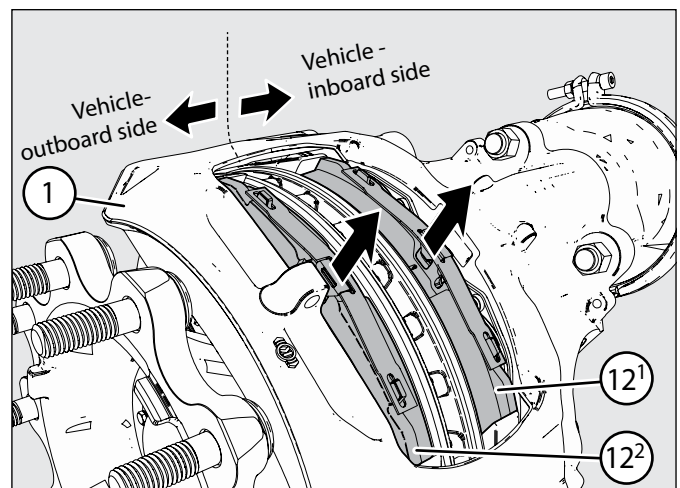

6.1.5 - Remove brake pads

6 Brake Pad Replacement

6.2 Fitting of Standard Brake Pads (without APR®-System)

! Pads must be changed as an axle set and NOT individually. Use only pads which are permitted by the vehicle manufacturer, axle manufacturer and disc brake manufacturer. Failure to comply with this will invalidate any Knorr-Bremse warranty.

6.2.1 Depending on the intensity of contamination, clean the brake pad bay area. Use suitable tools (wire brush, caliper file, blunt scraper).

Important! Take care not damage the Carrier and/or Rubber Bush/Guide Sleeve seals.

6.2.2 Check the carrier (2) and rubber seals for damage, replace if necessary.

Important! Brake Pad contact surface must be clean, devoid of moisture and free from any dirt and debris.

6.2.3 Depending on the application, it may be necessary for the abutments of the carrier and guiding surfaces of the brake pad to be lightly coated with lubricant (K125122N50) (see Fig.).

Important! Do not use copper based lubricant.

Important! Do not get any lubricant on the pad and/or disc face or guide sleeve parts.

Refer also to specifications provided by the vehicle, axle and brake system manufacturer.

! Before inserting the brake pads, fully wind back the tappet and boot assemblies (13) by rotating the shear adapter (61) in an anti-clockwise direction (see Section 5.2).

6.2.4 Insert the brake pads (12) as follows:

For **SK7** disc brakes the geometry of the brake pads (12) requires the following fitting procedure:

- Slide caliper (1) inboard and insert inner brake pad (12¹) (see Fig. 6.2.4a)
- Slide caliper (1) outboard and insert outer brake pad (12²) (see Fig. 6.2.4b)

For **SN6** and **SN7** disc brakes there is no special fitting order for the brake pads (12), therefore the inboard or outboard pad can be fitted first.

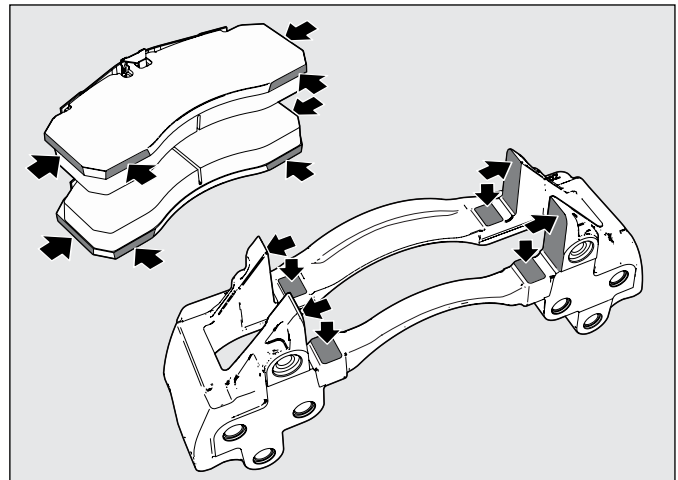

6.2.3 - Areas to apply suitable lubricant

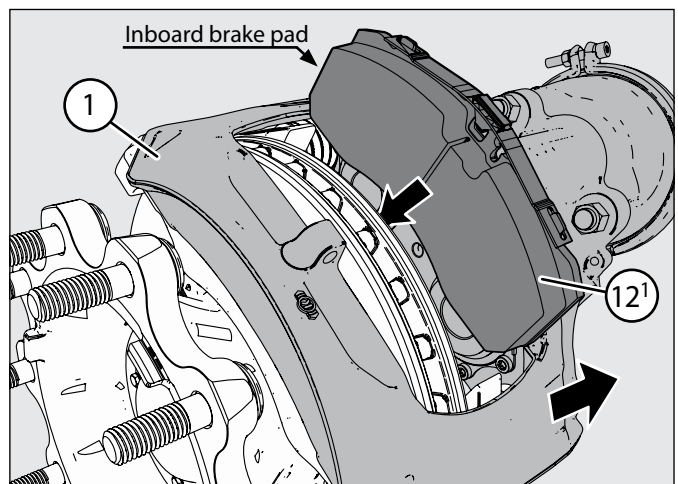

6.2.4a - Insert inboard brake pad (SK7)

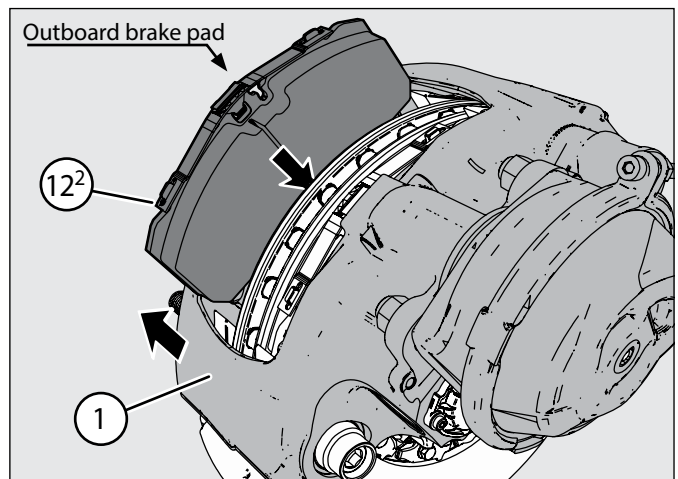

6.2.4b - Insert outboard brake pad (SK7)

6 Brake Pad Replacement

6.2.5 Wind out the Adjuster (23) with shear adapter (61) until the brake pads come into contact with the disc. Then turn back the adjuster **three clicks** and check the running clearance (see Section 5.2).

6.2.6 After fitting the pad retainer (11) into the groove of caliper (1), it must be depressed to enable the insertion of the pad retainer pin (44) (only use new parts) (see Fig.).

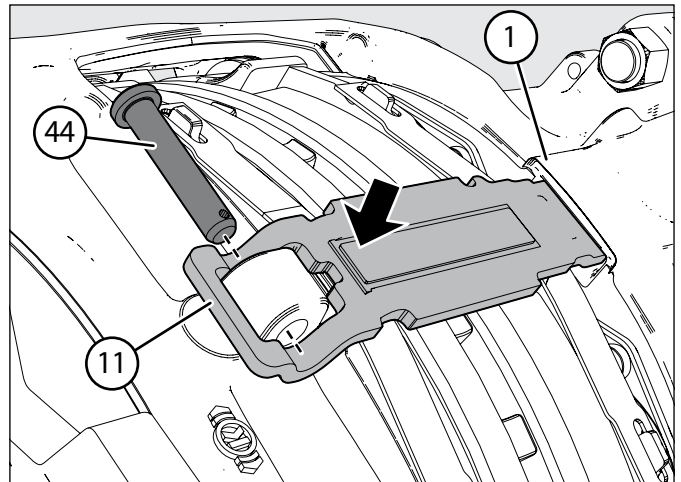

6.2.6 - Fitting pad retainer and pin

6.2.7 Fit new washer (45) and then new spring clip (26) to the pad retainer pin (44) (use only new parts) (see Fig.).

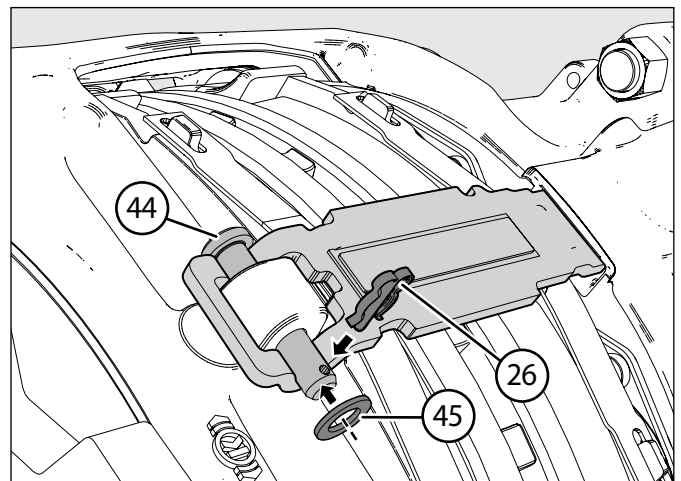

6.2.7 - Fit new washer and new spring clip

6.2.8 The adjuster cap (37) must then be replaced (use only a new cap) having lightly greased its contact surface with grease (available as Part No. I114525, K093430 or I132868) (see Fig.).

Note: The tag of the adjuster cap (37) should be positioned as shown (see arrow). This ensures access is maintained for subsequent removal.

If required, fit cable guides and pad wear indicators (see Section 6.5).

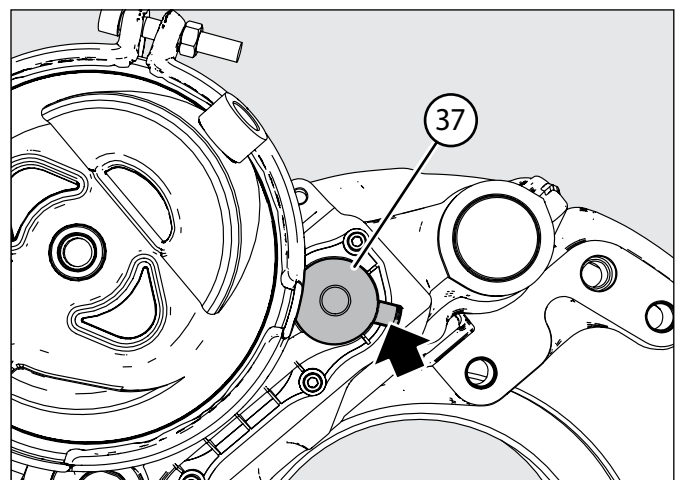

6.2.8 - Fit new adjuster cap, note tab position

 After any service work: Check the brake performance and the system behaviour on a roller dynamometer. Check function and effectiveness. Bear in mind that a lower performance can appear during the breaking-in phase of the brake pads and/or the brake disc.

6 Brake Pad Replacement

With Active Pad Release (APR) System

1....
2....
3....

6.3 Removal of Brake Pads (with APR®-System)

6.3.1 Remove wheel (refer to vehicle manufacturer's recommendations).

Important! Also be aware of the inspection points detailed in chapter 4, as well as checking the caliper free movement (see Section 5.3).

 Depending on the orientation of the caliper on the axle, brake pads could fall out when removing the pad retainer (11).

6.3.2 Remove spring clip (26) and washer (45), depress the pad retainer (11) and remove pin (44) (see Fig.).

If necessary remove any in-pad wear sensor components (see Section 6.5).

6.3.3 Pull off the adjuster cap (37) using the tab, taking care not to lose the shear adapter (61) (see Fig. insert).

 Do not use any tools to remove the cap (37) as this can damage the sealing elements of the adjuster.

6.3.4 Fully wind back the tappet and boot assemblies (13) by rotating the adjuster (23) via the shear adapter (61) in an anti-clockwise direction (as viewed from actuator side) – a loud clicking noise is generated (see Fig.).

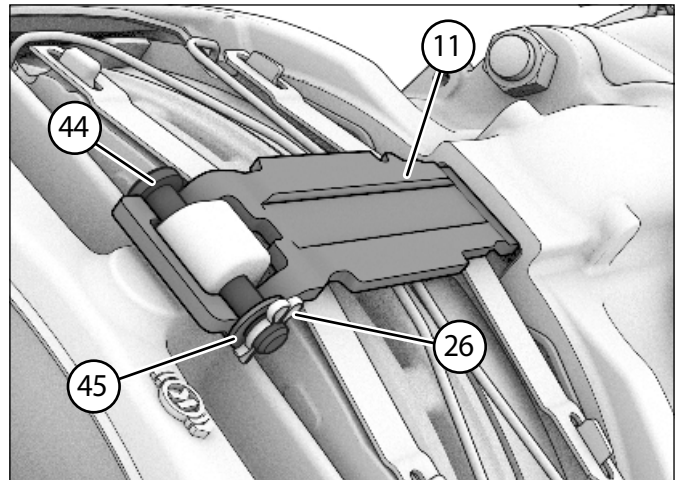

6.3.2 - Removing pad retainer

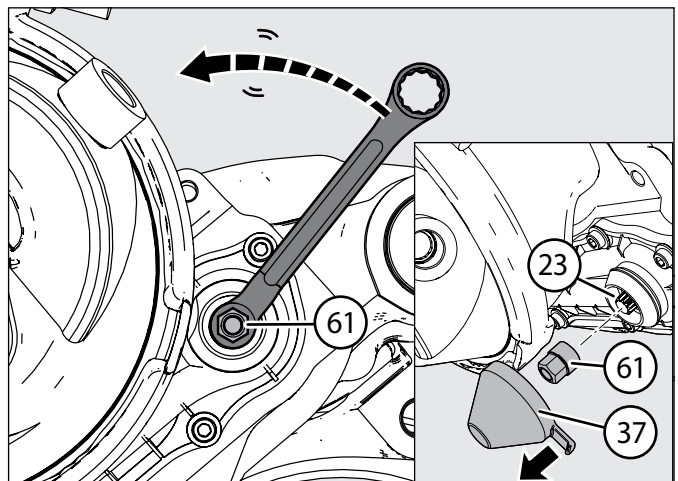

6.3.3 - 6.3.4 - Rewind adjuster using shear adapter

6.3.5 Release the ends of one APR spring element from one side of the brake using a suitable tool (e.g. screwdriver) and remove the APR (see Fig.).

6.3.6 Repeat the same process for the APR spring element on the other side of the brake (see Fig.).

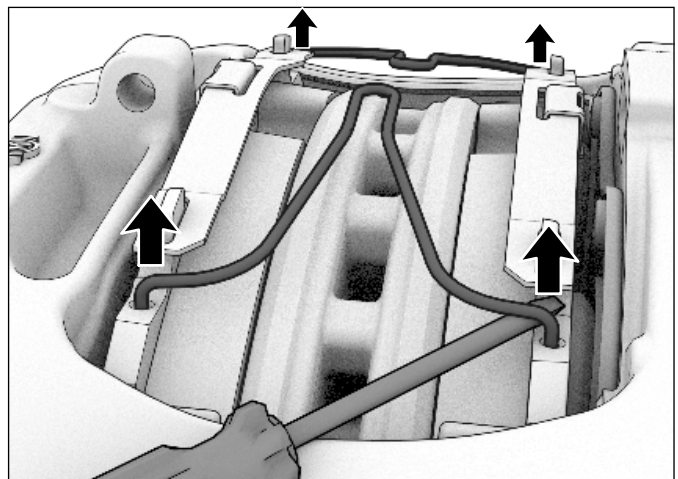

6.3.5 - 6.3.6 - Removal of the APR-Spring element

6 Brake Pad Replacement

With Active Pad Release (APR) System

1....
2....
3....

6.3.7 Remove brake pads (12¹) and (12²) (see Fig.).

Note: The geometry of the brake pad housing of **SK7** disc brakes require the following removal procedure of the brake pads (12):

- Pull caliper (1) towards the outboard side.
- Remove outer brake pad (12²)
- Push caliper (1) to the inboard side.
- Remove inboard brake pad (12¹)

6.3.8 Check caliper running clearance (see Section 5.3).

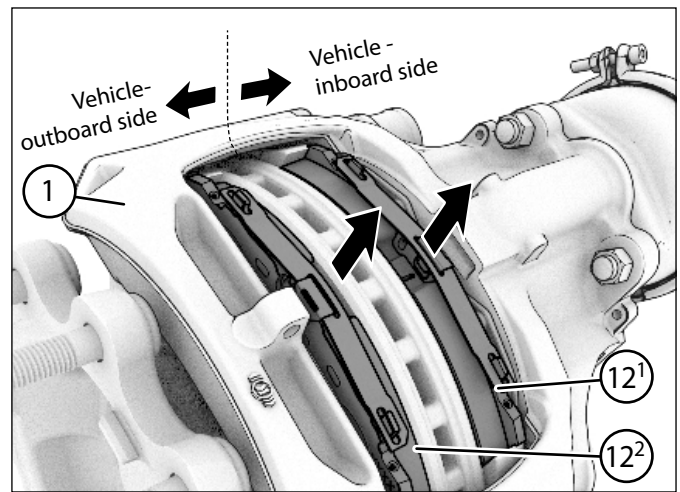

6.3.7 - Remove brake pads

6.4 Fitting of Brake Pads (with APR®-System)

! Pads must be changed as an axle set and NOT individually. Use only pads which are permitted by the vehicle manufacturer, axle manufacturer and disc brake manufacturer. Failure to comply with this will invalidate any Knorr-Bremse warranty.

! **Note: The APR®-System cannot be used in combination with a protective cover plate fitted to the pneumatic disc brake.**

6.4.1 Depending on the intensity of contamination, clean the brake pad bay area. Use suitable tools (wire brush, caliper file, blunt scraper).

Important! Take care not damage the Carrier and/or Rubber Bush/Guide Sleeve seals.

6.4.2 Check the carrier (2) and rubber seals for damage, replace if necessary.

Important! Brake Pad contact surface must be clean, devoid of moisture and free from any dirt and debris.

6.4.3 Depending on the application, it may be necessary for the abutments of the carrier and guiding surfaces of the brake pad to be lightly coated with lubricant (K125122N50) (see Fig.).

Important! Do not use copper based lubricant.

Important! Do not get any lubricant on the pad and/or disc face or guide sleeve parts.

Refer also to specifications provided by the vehicle, axle and brake system manufacturer.

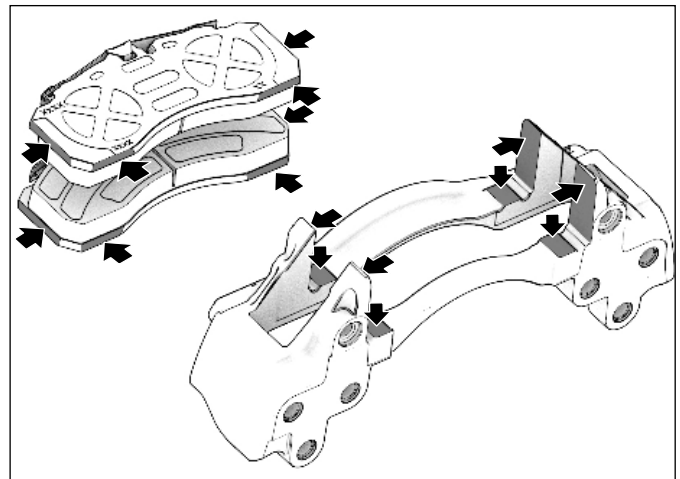

6.4.3 - Areas to apply suitable lubricant

6 Brake Pad Replacement

With Active Pad Release (APR) System

 Before inserting the brake pads, fully wind back the tappet and boot assemblies (13) by rotating the shear adapter (61) in an anti-clockwise direction (see Section 5.2).

6.4.4 Insert the brake pads (12) as follows:
For **SK7** disc brakes the geometry of the brake pads (12) requires the following fitting procedure:

- Slide caliper (1) inboard and insert inner brake pad (12¹) (see Fig. 6.2.4a)
- Slide caliper (1) outboard and insert outer brake pad (12²) (see Fig. 6.2.4b)

For **SN6** and **SN7** disc brakes there is no special fitting order for the brake pads (12), therefore the inboard or outboard pad can be fitted first.

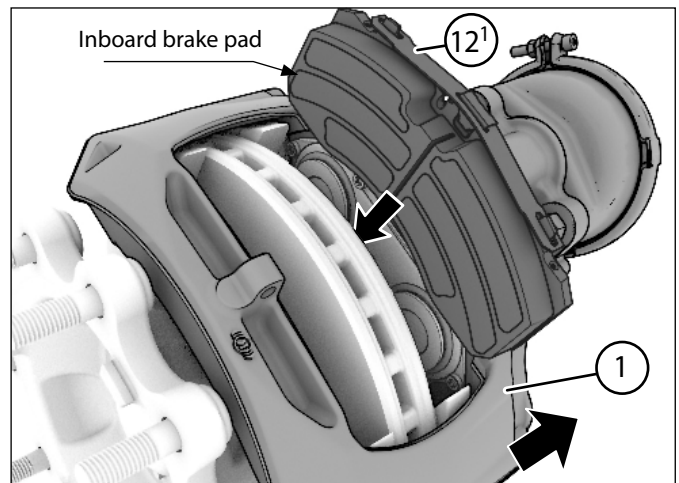

6.4.4a - Insert inboard brake pad (SK7)

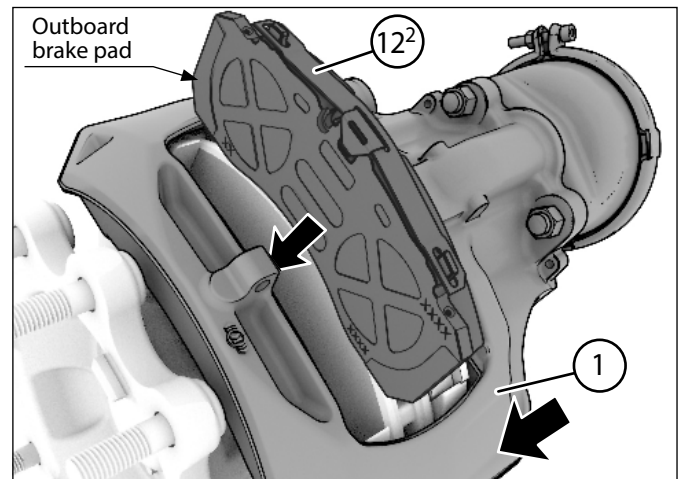

6.4.4b - Insert outboard brake pad (SK7)

6.4.5 Align one APR spring element to one side of the brake and insert both ends into each pad.

6.4.6 Repeat for the other side inserting the ends of the other APR into each pad.

6.4.7 Press all ends of the APR spring elements down as far as they go so that the markings on the spring match the upper edge of the holes in the pads.

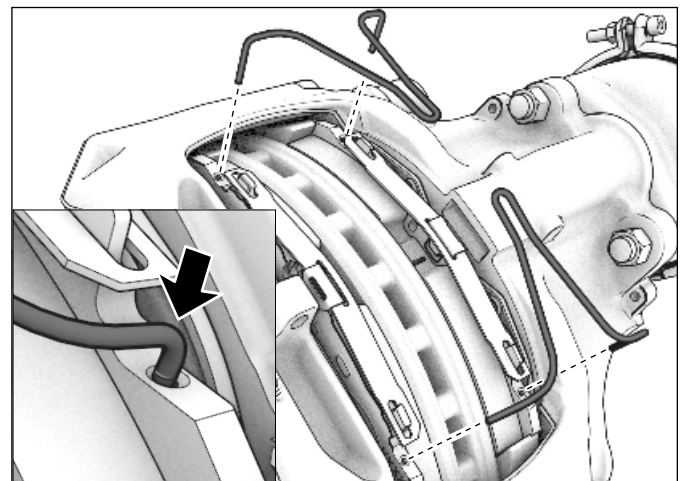

6.4.5 - 6.4.7 - Fitting of the APR-Spring element

6 Brake Pad Replacement

With Active Pad Release (APR) System

6.4.8 Wind out the Adjuster (23) with shear adapter (61) until the brake pads come into contact with the disc. Then turn back the adjuster **three clicks** and check the running clearance (see Section 5.2).

6.4.9 After fitting the pad retainer (11) into the groove of caliper (1), it must be depressed to enable the insertion of the pad retainer pin (44) (only use new parts) (see Fig.).

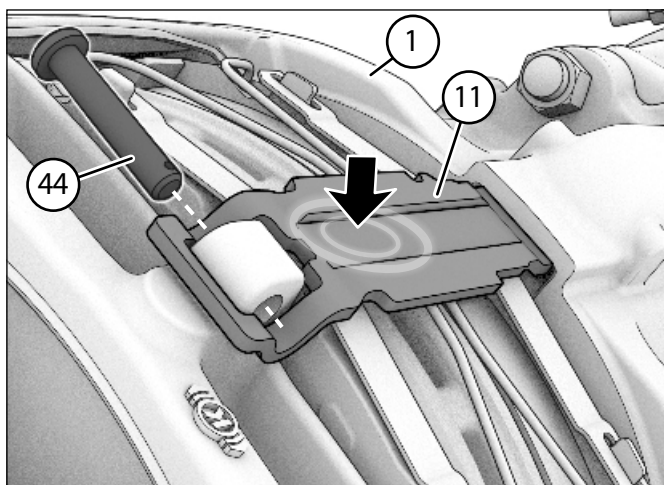

6.4.9 - Fitting pad retainer and pin

6.4.10 Fit new washer (45) and then new spring clip (26) to the pad retainer pin (44) (use only new parts) (see Fig.).

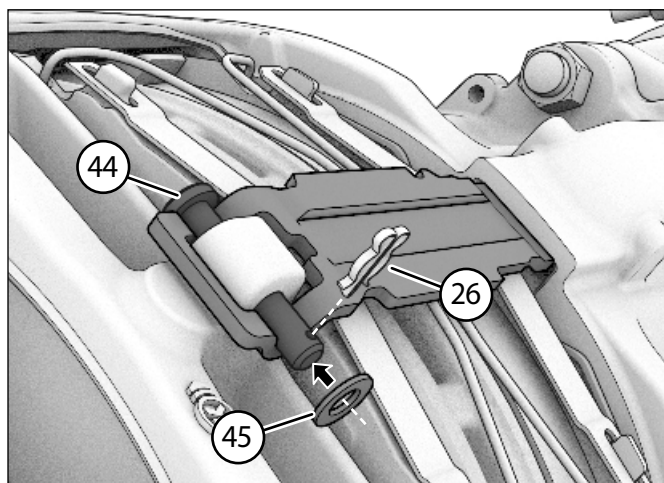

6.4.10 - Fit new washer and new spring clip

6.4.11 Pad retainer (11) secured in place (see Fig.).

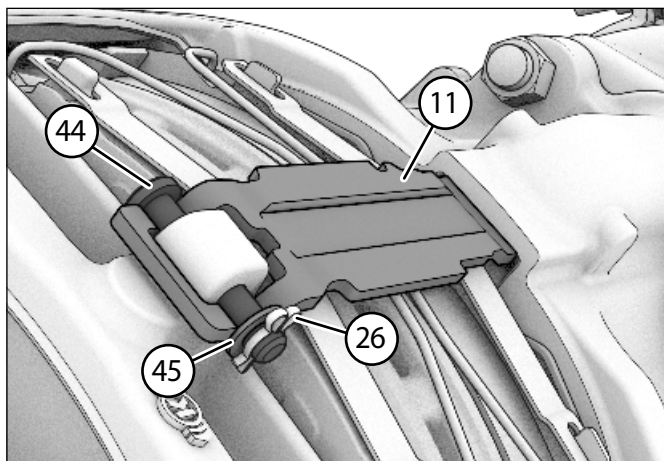

6.4.11 - Pad retainer secured in place

6 Brake Pad Replacement

6.5 Fitting Pad Wear Indicators (without APR system)

! Only use new pad wear indicators. The fitting of used pad wear indicators is not allowed.

For pad removal see section 6.1.

The fitting of the Pad Wear Indicator is identical for brakes with or without APR.

The components of the wear indicator kits are shown in section 1.2.1.

Note: The longer end of the cable fits onto the outboard pad (12²), the short end onto the inboard pad (12¹).

6.5.1 Align each sensor in the groove of a brake pad (12) and press down until it locks into place (see Fig.).

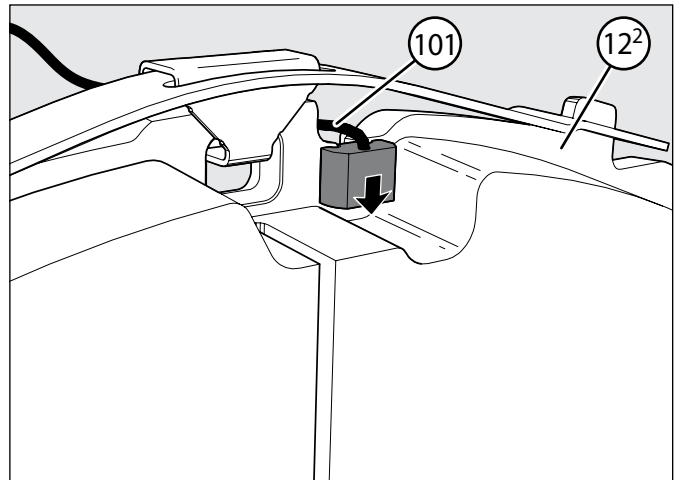

6.5.1 - Fitting pad wear indicators

6.5.2 Insert the brake pads (12) with pre-assembled wear indicators into their respective brake pad bay area (see Fig.).

Note: See also section 6.2.2.

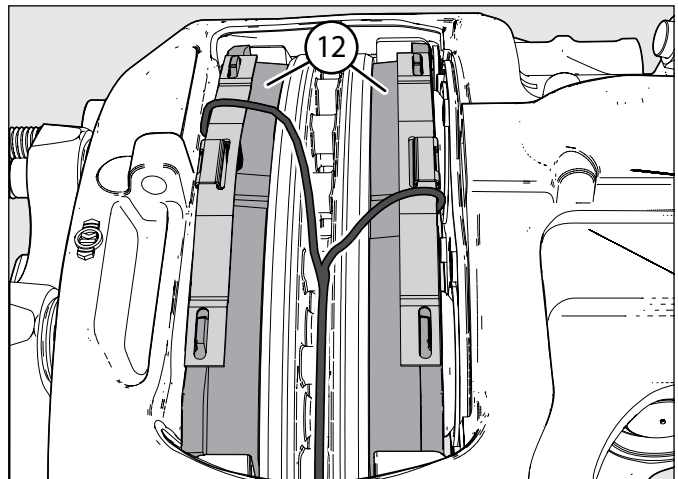

6.5.2 - Insert pre-assembled pads

6.5.3 Fit pad retainer (11) with retainer pin (44), washer (45) and spring clip (26) (see Fig. and Section 6.2). Note the correct position of the cables (101) (see arrows).

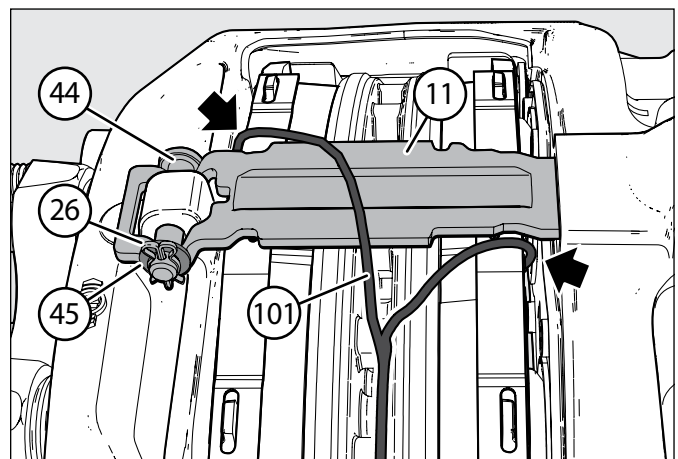

6.5.3 - Fit pad retainer

6 Brake Pad Replacement

Fitting of Cable Guide Variant (105)

6.5.4 Fit the cable guide variant (105) onto the pad retainer (11). When correctly positioned, and whilst applying light pressure, the cable guide (105) will lock easily into place (see Fig.).

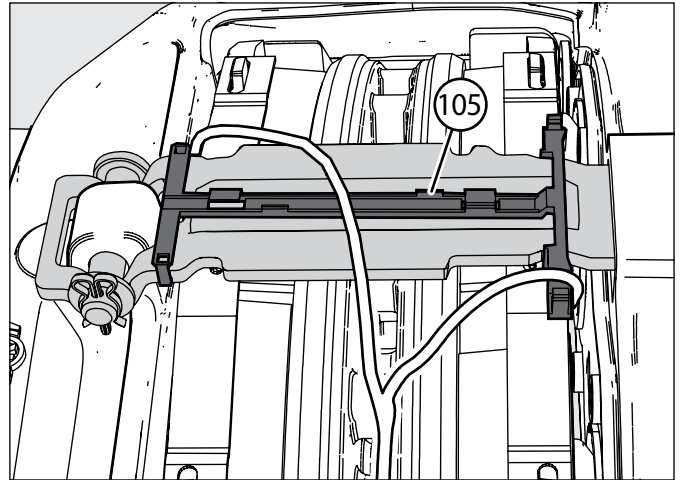

6.5.4 - Fitting cable guide

6.5.5 Carefully insert the cable (101) into the retainer tabs (arrows **A**) of the cable guide (105). Note that the shorter cable from the inboard pad is not fixed to any part of the cable guide (105) (arrow **C**).

Depending on the vehicle type, the supply line of the cable (101) is fixed into one of the outer retainer clips (arrow **B**).

Note: The short cable (inboard side) remains loose (arrow **C**).

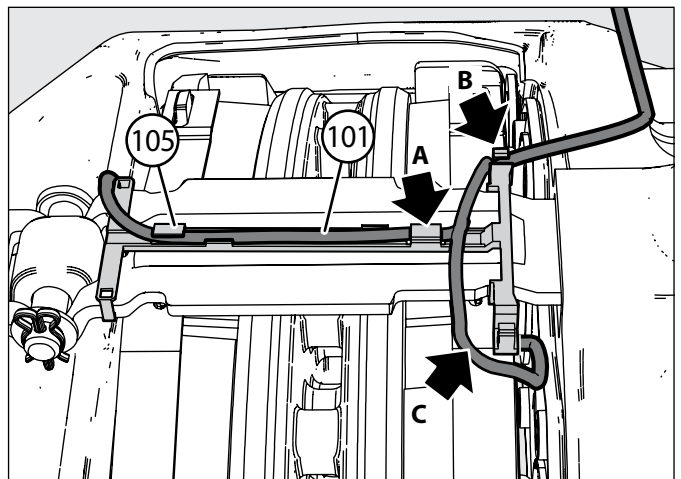

6.5.5 - Cable fixture position on cable guide (105)

Fitting of Cable Guide Variant (105a)

6.5.6 Lay the cable (101) centrally on the pad retainer (11). Position the cable guide (105a) at the side of the pad retainer (11) (arrow **D**) and with light pressure clip into place on the opposite side (see Fig.).

Depending on the vehicle type, the supply line of the cable (101) is fixed into one of the outer retainer clips (arrow **B**).

Note: The short cable (inboard side) remains loose (arrow **C**).

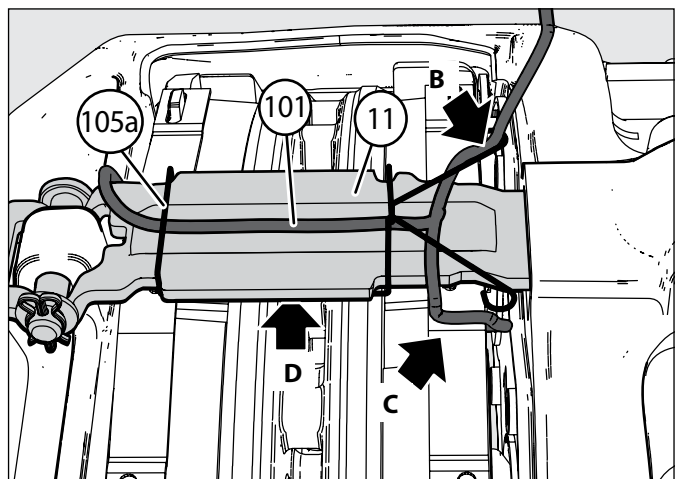

6.5.6 - Cable fixture position on cable guide (105a)

6 Brake Pad Replacement

Fitting of Cable Protection Plate (104)

6.5.7 Position cable protection plate (104) on one side of the pad retainer (11), making sure the tab (arrow **E**) is located correctly. By applying central pressure on plate (104) the tab will snap into place (see main Fig. and detailed view).

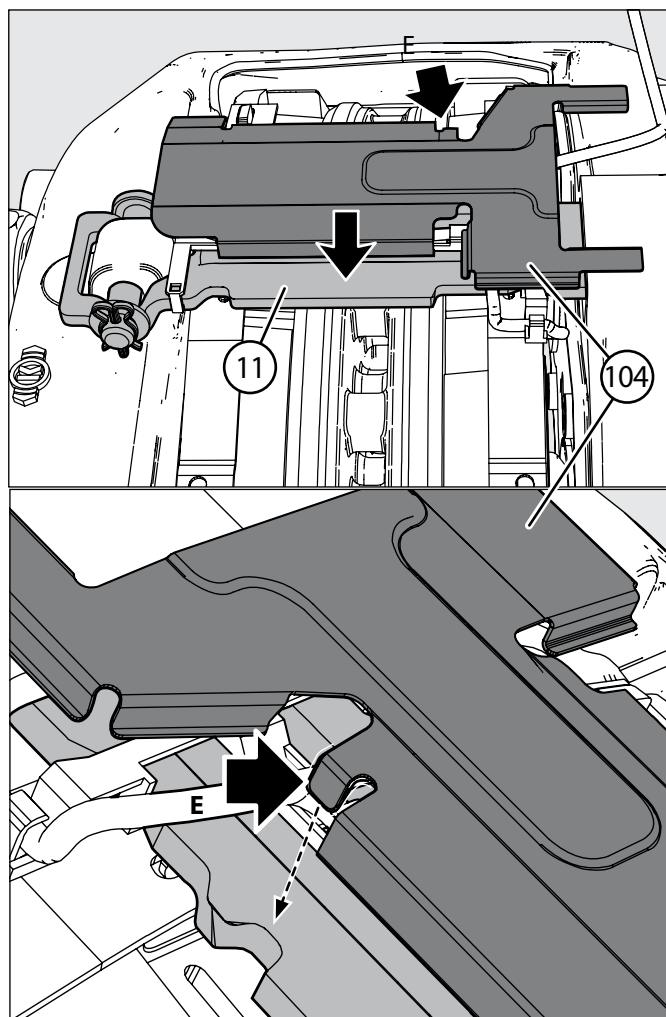

6.5.7 - Fitting cable protection plate

Removing Cable Protection Plate (104)

6.5.8 Using a suitable tool, loosen one side of the cable protection plate (104) and remove.

It is not permitted to reuse a cable protection plate.

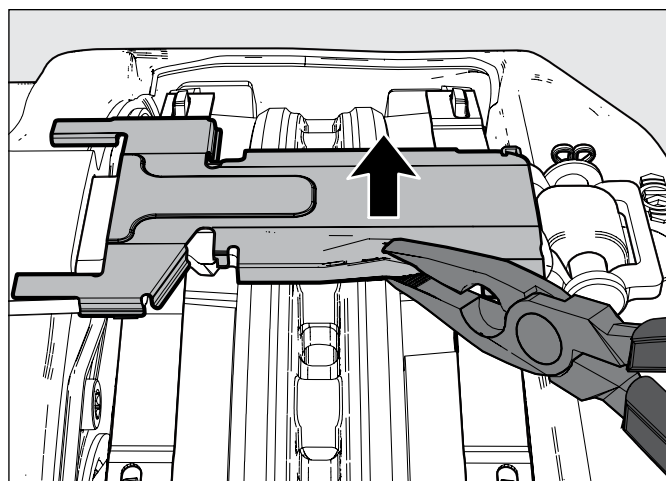

6.5.8 - Removing cable protection plate

7. Tappet and Boot Assemblies (13) and Inner Seals (22) Replacement

For ease of reference, each component of a tool is referred to by an identification number; a complete tool (containing one or more such components) has been given a letter code - see section 2.1.

To remove the tappet and boot assemblies (13) use the wedge fork **(A)** (see Fig 7a).

To fit the tappet and boot assemblies (13), use tool **(B)** (see Fig 7b).

To fit the inner seal (22), use tool **(C)** in configuration **(C¹)** when the caliper is mounted on the vehicle or configuration **(C²)** when removed from the vehicle (see Fig 7c).

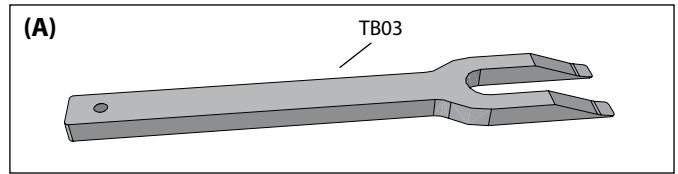

7a - Tool for replacing the tappet and boot assemblies

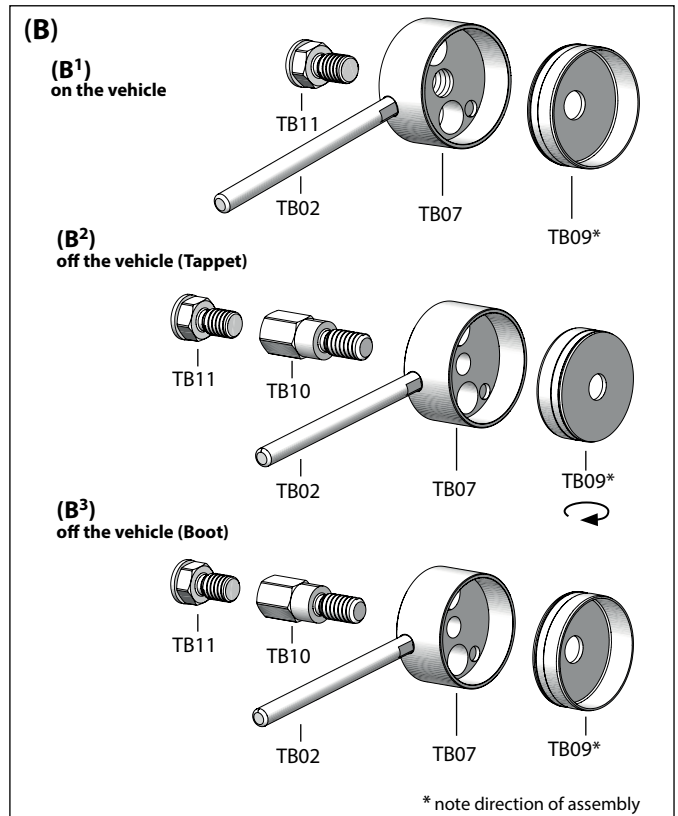

7b - Tool for fitting the tappet and boot assemblies

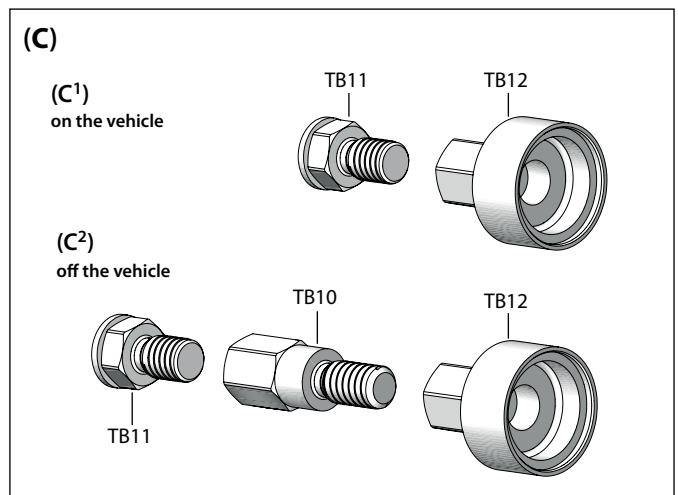

7c - Tool for fitting the inner seal

7 Tappet / Boot Assemblies (13) and Inner Seals (22) Replacement

7.1 Removal of Tappet and Boot Assemblies (13)

Note: The removal of the tappet and boot assemblies (13) can be done with the brake caliper fitted to, or removed from, the vehicle (see Section 8).

With caliper installed on the vehicle:

7.1.1 Wind-out the adjuster (23) using the shear adapter (61) until the boots are easily accessible (**max. 30 mm**) and with a suitable lever carefully prise the boot away from the caliper (see Fig.).

Take extra care not to damage the sealing surface on the caliper for the inner boot (arrow **X**) as this cannot be replaced (see Fig.).

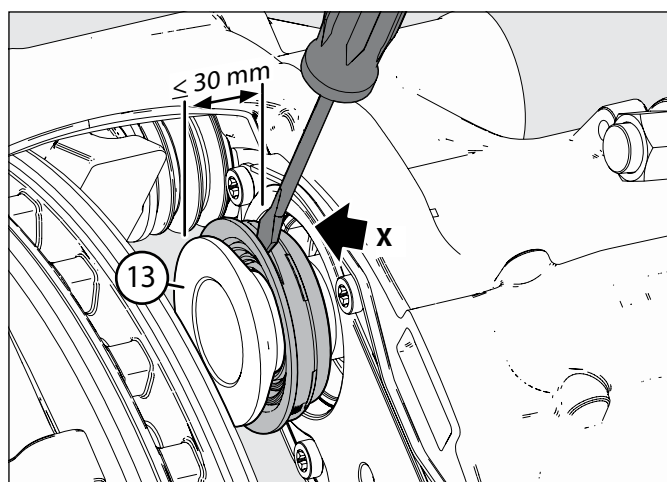

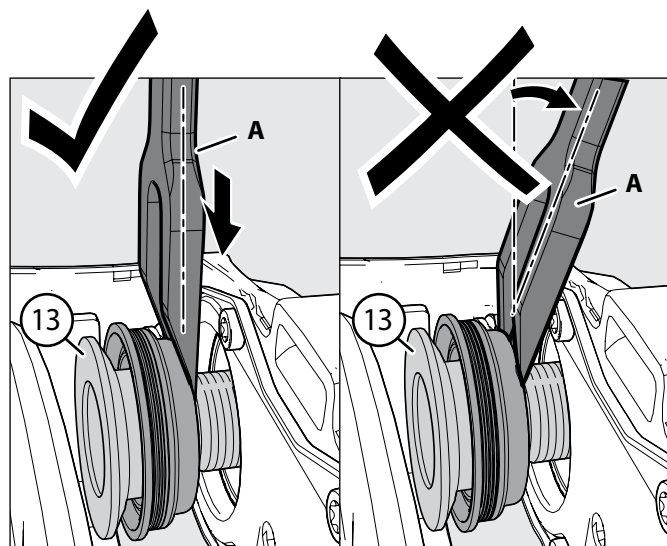

7.1.1 - Wind-out the adjuster, prise out the inner boot.

7.1.2 Using tool (A), correctly positioned between the caliper and the boot, carefully drive it down with the aid of a hammer to release each tappet and boot assembly (13) from its threaded tube (16). Take care to stay perpendicular and not damage the threaded tube (see Figs. 'a' and 'b').



7.1.2a - Remove tappet and boot assembly using tool (A)

 Make sure to keep tool (A) perpendicular to the threaded tube.

 Do not remove the tappet by levering with tool (A) at an angle, this will damage the internal mechanism.

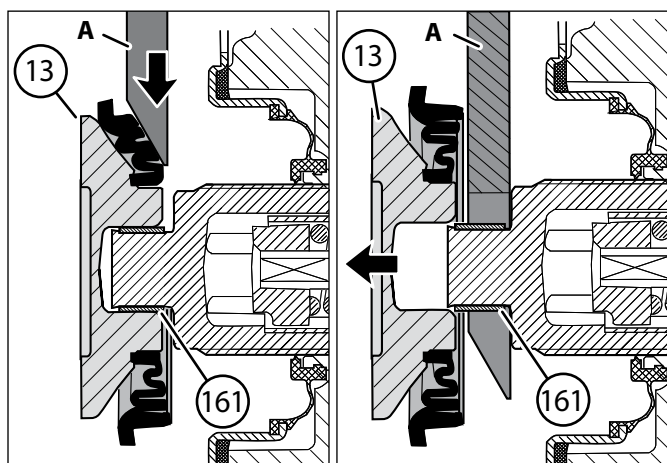

7.1.2b - Drive down wedge fork using hammer

7 Tappet / Boot Assemblies (13) and Inner Seals (22) Replacement

7.1.3 Remove the old tappet bush (161) (see Fig.).

7.1.4 Check inner sealing face (arrow **X**) (see Fig.).

 This sealing face (arrow **X**) must not be damaged. It cannot be replaced. If it is damaged, the caliper must be replaced. (see Section 8).

If the seal is damaged then the caliper must be replaced (see Section 8).

Note: When replacing tappet and boot assemblies (13), the inner seals (22) must also be replaced (see Section 7.2).

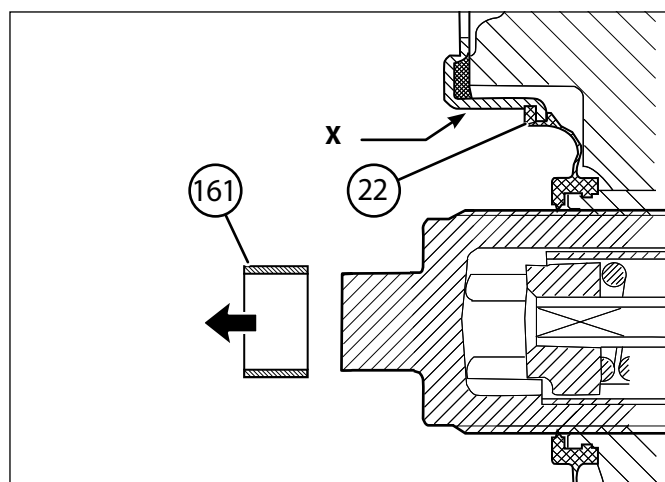

7.1.3 - 7.1.4 - Remove tappet bush, check sealing face

Inspection of Threaded Tube (16)

7.1.5 Place a new brake pad (12) in the outboard position and wind-out the threaded tube (16), by turning the shear adapter (61), until it touches the brake disc. Check the threads when winding-out for corrosion and damage (see Fig.).

In case of water ingress or corrosion, the caliper must be replaced (see Section 8).

 The threaded tubes must **not** extend more than **30 mm**, otherwise synchronisation is lost and the caliper must be replaced.

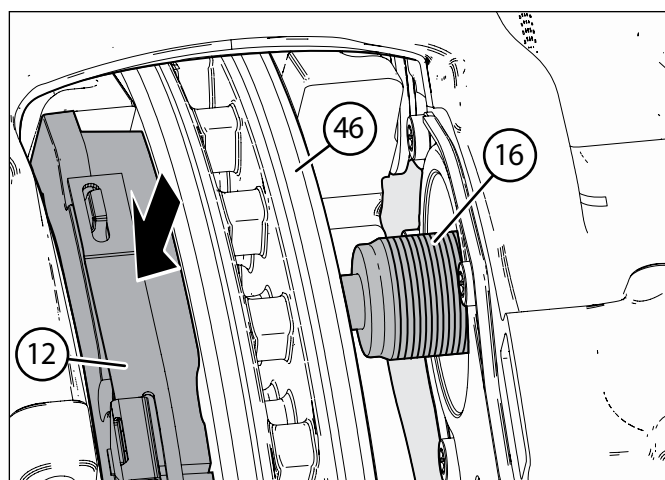

7.1.5 - Inspection of threaded tube (installed on vehicle) using new brake pad

With caliper removed from the vehicle:

7.1.6 If the caliper is not installed on the vehicle, place spacer **S** (length = **70 mm**) into the caliper (1) to avoid loss of thread engagement of the threaded tubes (16). Check the threads when winding-out for corrosion and damage (see Fig.).

In case of water ingress or corrosion, the caliper must be replaced (see Section 8).

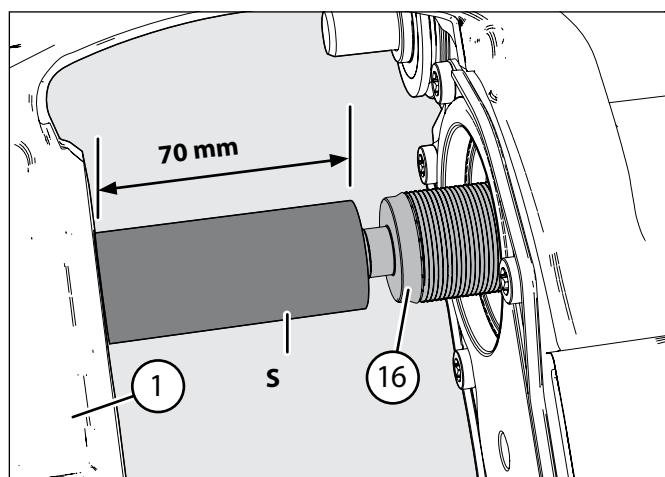

7.1.6 - Inspection of threaded tube (removed from vehicle) using spacer

7 Tappet / Boot Assemblies (13) and Inner Seals (22) Replacement

7.2 Replacement of Inner Seals (22)

7.2.1 Fully wind back the threaded tubes (16) by turning the shear adapter (61) (see Section 6.1.4).

7.2.2 Clean area of the inner seal (22) and then, using a suitable lever (Y), carefully remove the inner seal (22) (see Fig.).

 The sealing surface for the inner seal (22), must not be damaged else the caliper must be replaced.

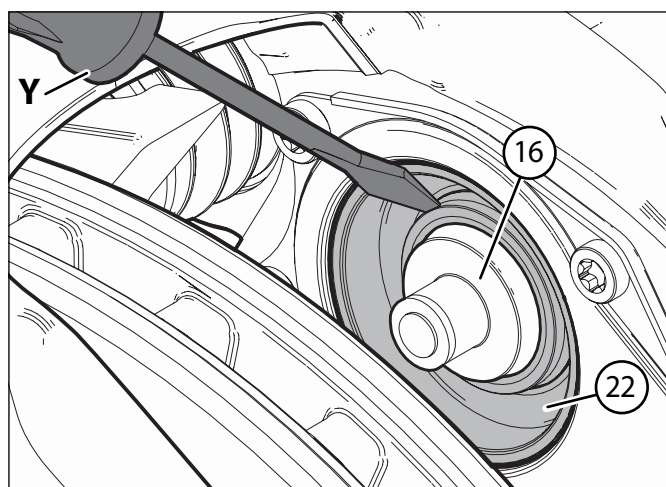

7.2.2 - Clean area and remove inner seal

7.2.3 Clean sealing surface (X) (see Fig.).

7.2.4 Wind-out the threaded tubes via the shear adapter (61) to a maximum of **30 mm** whilst at the same time inspecting them for corrosion or damage (see Section 7.1.5 -7.1.6).

7.2.5 Lubricate threads with white grease (Part No. II14525, K093430 or II32868) and then wind back the threaded tubes until they stop (see Fig.).

7.2.6 Fit new inner seals (22) onto the threaded tubes (16) and carefully push into position.

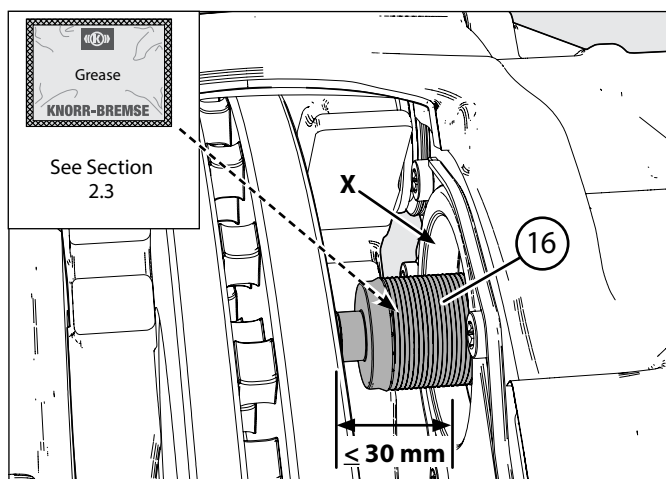

7.2.3 - 7.2.5 - Wind out threads, inspect, grease threads and wind back

7 Tappet / Boot Assemblies (13) and Inner Seals (22) Replacement

With caliper installed on the vehicle:

7.2.7 Guide the tool (C¹) over the spigot of the threaded tube (16) as shown, screw out (TB11) until it touches the brake disc (see Fig.).

Note: The tappet bush (161) must be absent for this procedure.

7.2.8 Fully press in the inner seal (22) by securing (TB12) with a spanner 27 A/F and rotating (TB11) against the brake disc using a second spanner until it stops (see Fig.).

7.2.9 Unscrew (TB11) and completely remove tool (C¹).

7.2.10 Check the correct fitting of the inner seal (22) by winding out the threaded tubes (16) four or five threads via the shear adapter (61).

Note: The inner seal (22) must not turn.

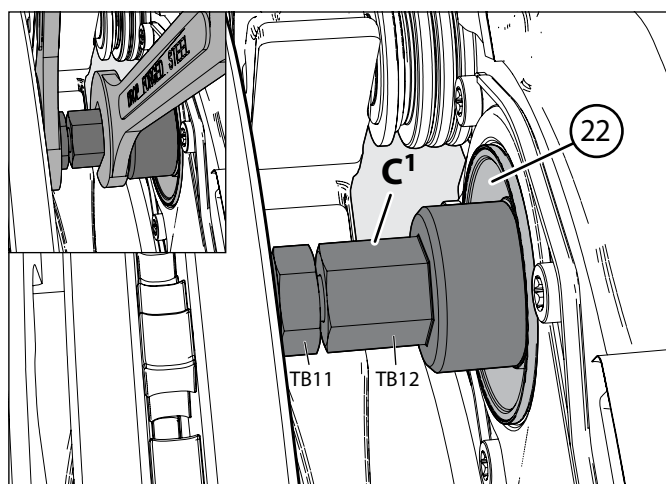

7.2.7 - 7.2.8 - Using press-in tool C¹ to fully press in inner seal

With caliper removed from the vehicle: (not shown):

The fitting sequence of inner seal (22) is basically the same as when the caliper is installed on the axle (see previous section), except the press-in tool (C²) with (TB11+T10+TB12) is required to press in inner seal (22).

7.2.11 Guide the tool (C²) over the spigot of the threaded tube (16), screw out (TB11) until it touches the brake disc.

Note: The tappet bush (161) must be absent for this procedure.

7.2.12 Fully press in the inner seal (22) by securing (TB12) with a spanner 27 A/F and rotating (TB11) against the brake disc using a second spanner until it stops.

7.2.13 Unscrew (TB11) and completely remove tool (C²).

7.2.14 Check the correct fitting of the inner seal (22) by winding out the threaded tubes (16) four or five threads via the shear adapter (61). Check that the inner seals (22) do not turn.

Note: If the inner seal (22) turns, then the seal must be removed and the procedure repeated using a new inner seal.

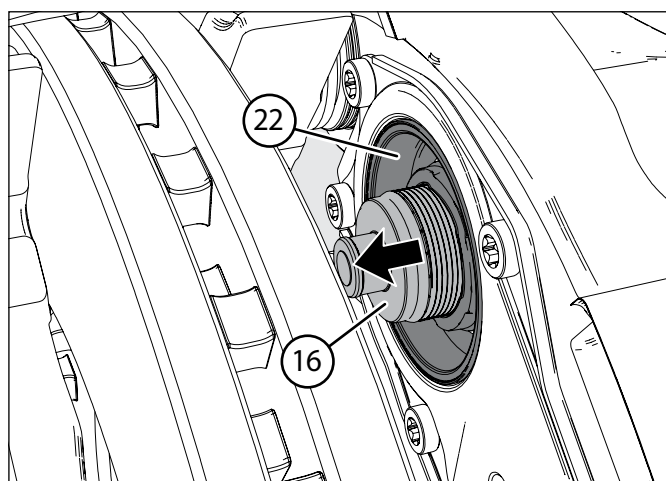

7.2.10 - wind out threaded tubes 4-5 threads via shear adapter

7.3 Fitting of Tappet and Boot Assemblies (13)

 The Tappets are supplied with a special long-life lubricant within a protective cap. Before fitting, the protective cap must be removed and discarded in the appropriate manner. The lubricant must not be smudged or removed. Transfer of the lubricant to other parts should be avoided. Also adding additional lubrication from any other substance is not allowed.

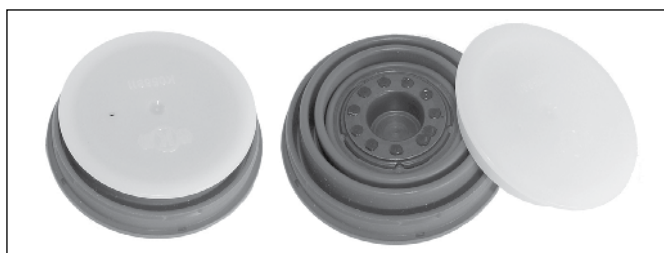

7.3 - Tappets supplied with long-life lubricant and protective cap

With caliper installed on the vehicle:

7.3.1. To fit the tappet and boot assemblies (13), use tool (B¹) (see Fig.).

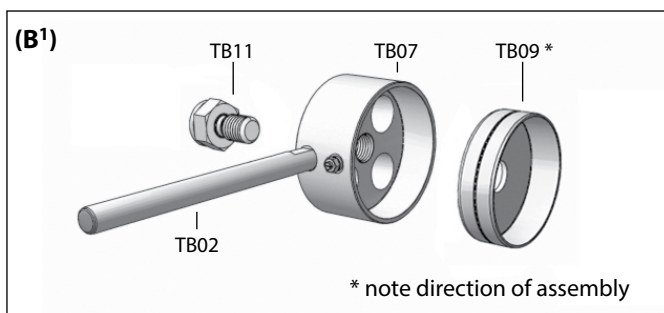

7.3.1 - Press-in tool (B¹)

7.3.2. Wind back fully the threaded tube (16) until it stops and then wind forward one full turn (see Section 6.1.4).

7.3.3. Fit new tappet bushes (161) onto the spigots of the threaded tubes (16), then follow with the tappet and boot assemblies (13) pushing them into position (see Fig.).

Note: The sealing surface (X) on the boot and in the caliper must be clean and free of lubrication.

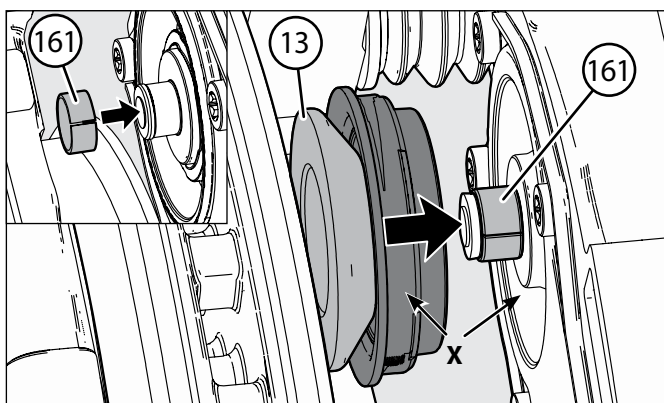

7.3.3 - Fit new tappet bush / tappet with boot assembly to the spigot

7.3.4. Position tool (B¹) so that (TB07) and outer rim (TB09) touches the brake disc. Using a spanner, screw out (TB11) to press tappet and boot assembly (13) into place (see Fig.).

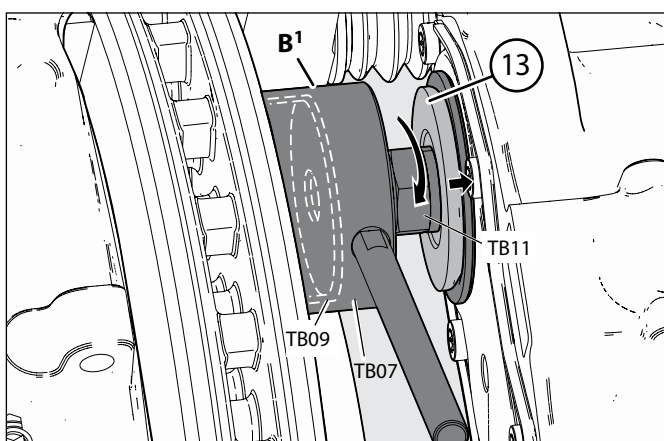

7.3.4 - Press in the tappet using tool (B¹)

7 Tappet / Boot Assemblies (13) and Inner Seals (22) Replacement

7.3.5 Release tool (**B**¹) and then turn it over so that tool (TB09) can make contact with the boot.

Note: The seal seating area for the tappet boot on the caliper housing must be clean and grease free.

7.3.6 Bring tool (**B**¹) into position making sure it is centralised to the tappet (see Fig.).

7.3.7 Press-in the boot of the tappet (13) using tool (**B**¹) by winding out (TB11) against the brake disc (see Fig.).

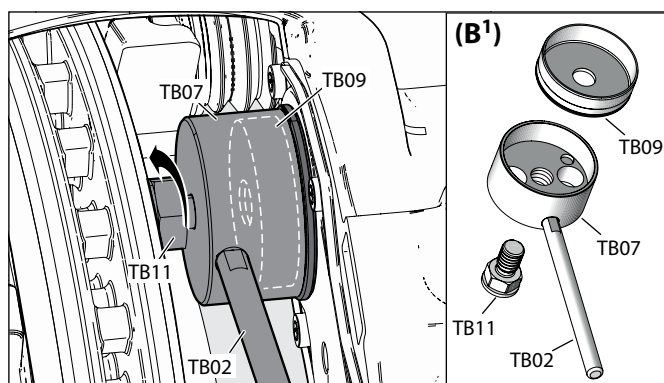

7.3.6 - 7.3.7 - Press-in boot using tool (**B**¹).

7.3.8 Check that the tappet (13) turns slightly in each direction (take care not to overstretch the tappet boot) (see Fig.).

Remove tool combination (B**¹).**

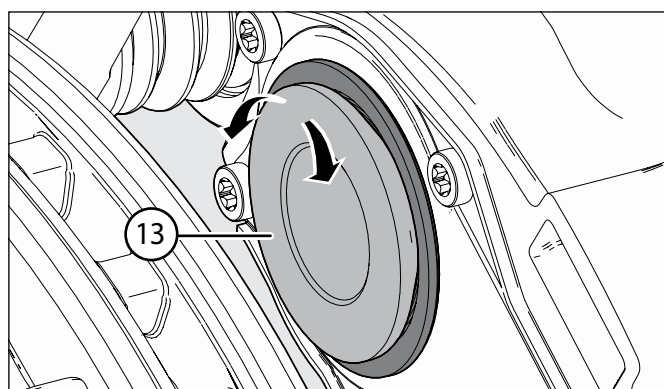

7.3.8 - Tappet should turn slightly in each direction

With caliper removed from the vehicle:

The fitting of each tappet and boot assembly (13) requires tool (**B**²) (see Section 7).

7.3.9 Wind back fully the threaded tube (16) using shear adapter (61) until it stops and then wind forward one full turn (see Section 6.1.4).

Note: The sealing surface (**X**) on the boot and in the caliper must be clean and free of lubrication.

7.3.10 Fit new tappet bushes (161) onto the spigots of the threaded tubes (16), then follow with the tappet and boot assemblies (13) pushing them into position.

7.3.11 Position tool (**B**²) as shown. Note that tool (TB09) must be inserted into tool (TB07) with closed side facing out. Using a spanner screw out (TB11) to press tappet and boot assembly (13) into place.

Note: Tool (TB09) is required to maximise grip on the caliper.

7.3.12 Release and remove tool (B**²).**

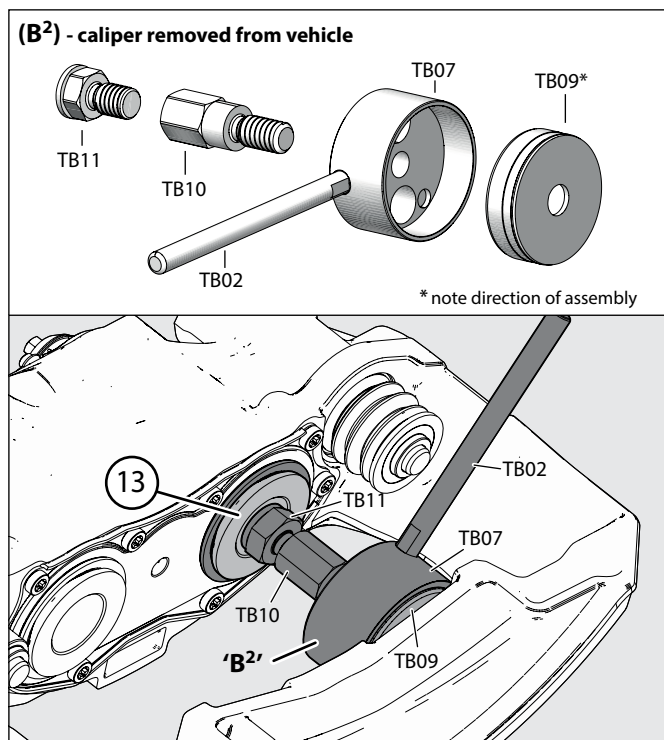

7.3.11 - Press in tappet using tool (**B**²) with TB09

7 Tappet / Boot Assemblies (13) and Inner Seals (22) Replacement

7.3.13 To press in the boot of the tappet (13) tool (**B³**) is required. Note that (TB09) must be inserted into (TB07) with open end facing outwards (see Fig.).

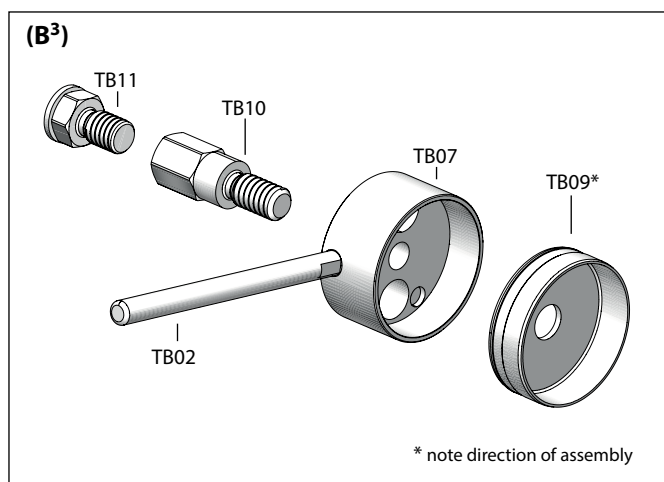

7.3.13 - Tool (**B³**)

7.3.14 Position tool (**B³**) so that (TB11) screws out against the caliper as shown. Using a spanner, screw-out (TB11) to press-in the boot (see Fig.).

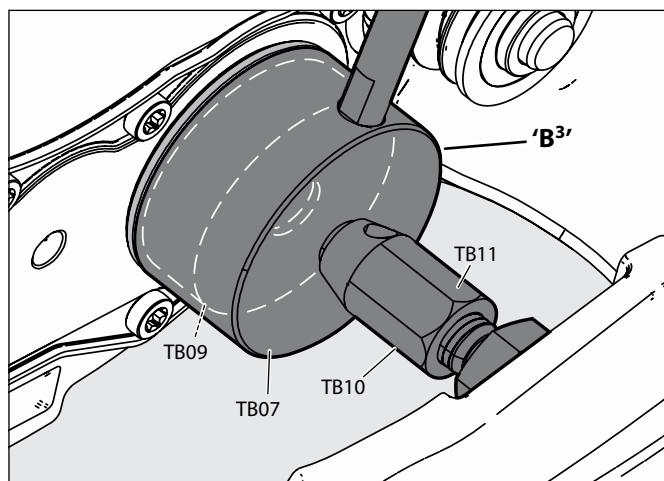

7.3.14 - Press-in the boot of the tappet using tool (**B³**)

7.3.15 Release and remove tool (**B³**), check that the tappet (13) turns slightly in each direction (take care not to overstretch the tappet boot) (see Fig.).

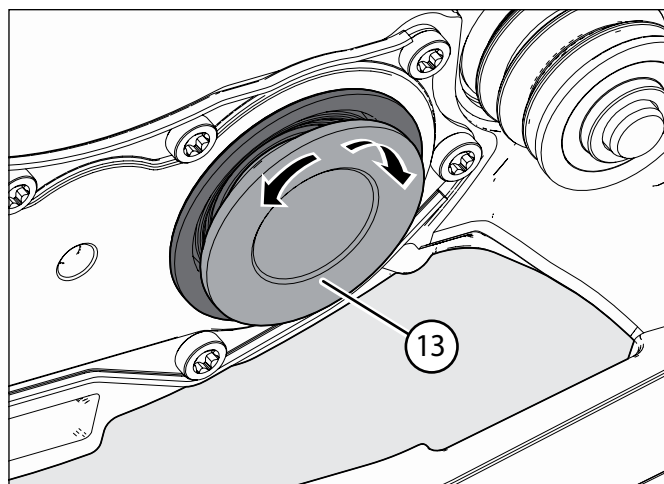

7.3.15 - Tappet should turn slightly in each direction

8. Caliper Replacement

For ease of reference, each component of a tool is referred to by an identification number; a complete tool (containing one or more such components) has been given a letter code - see section 2.1.

Use the following tools to replace covers:

8.0 To replace the cover (10) fixed bearing use the press-in tool **N** (TB20), for cover variants (68) floating bearing use the following:

- For cover (68a; Rubber Bush and 68f; Double Roll Bearing) press-in tool **O** (TB06 + TB14)
- For cover (68c and 68e; guide sleeve) use press-in tool **P** (TB20 + TB22)
- For cover (68d; capped rubber sleeve) tool **R** (TB06 + TB13) (see Fig.).

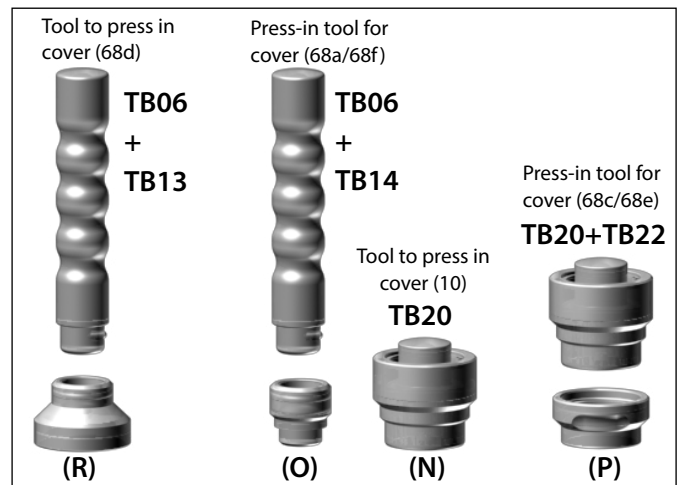

8 - Press-in tools for cap and covers

8.1 Removal of Caliper from Carrier

8.1.1 Remove the brake pads (12) (see Section 6.1).

8.1.2 Remove brake actuator (see Section 12). If fitted, remove wear indicator cable and potentiometer.

⚠ Do not touch electrical contact points - possible static discharge!

Note: It may be necessary for reasons of accessibility to remove the caliper and carrier from the axle (refer to vehicle manufacturer's recommendations) or remove only the caliper.

Removal of Cover (10) - Fixed Bearing Side

8.1.3 Use a suitable tool (e.g a chisel) to centrally penetrate the cover (10) creating a hole to allow easy removal (see Fig.).

Note: during penetration the cover (10) may move approximately 10 mm inwards.

⚠ Cover (10) should be penetrated in the middle. Do not drive the tool between caliper bore and cover (10) since caliper bore may be damaged.

⚠ Do not drive the tool too deeply, otherwise the seal for the cover may get damaged when removing.

8.1.4 Remove cover (10) using a suitable tool (e.g a screwdriver) by inserting it into the created hole and levering it out.

Check the inside area of the bearing for dirt or corrosion. If necessary replace with a new guide and seal kit. In case of damage or excessive corrosion, the caliper must be replaced.

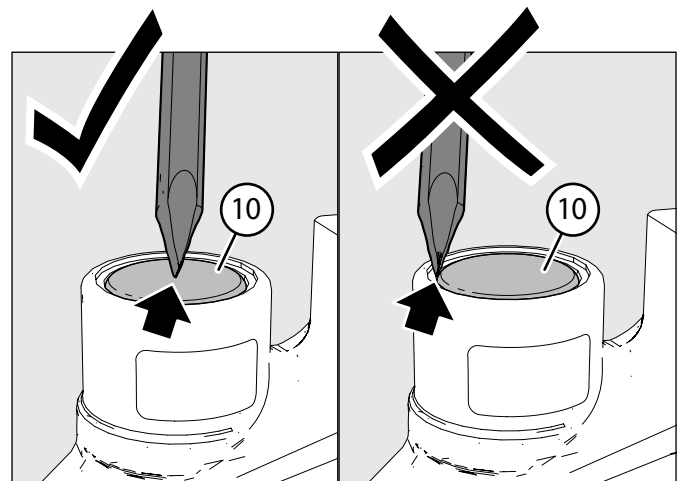

8.1.3 - Penetrate cover in the centre using suitable tool

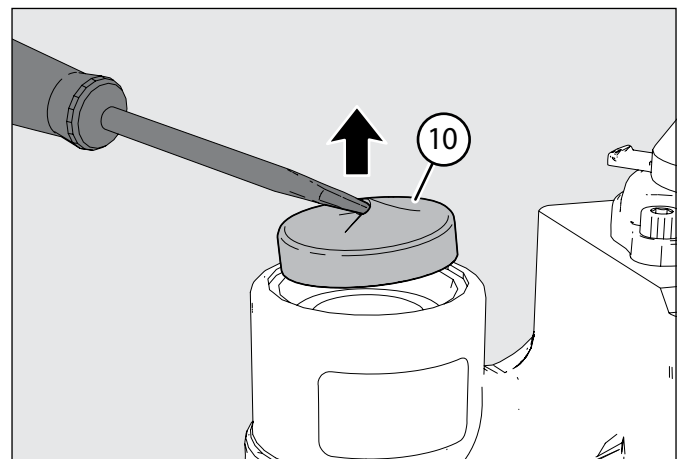

8.1.4 - Remove cover using suitable tool

8 Caliper Replacement

1....
2....
3....

Removal of Cover (68c, 68e; Guide Sleeve) or (68d; Capped Rubber Sleeve)

8.1.5 Due to the protrusion of covers (68c, 68d or 68e), the removal procedure is from the side and in an upward direction as shown (see Fig.).

Note: Do not hit the covers (68c, 68d or 68e) in direction of the caliper as damage may occur to the caliper.

Check the inside area of the bearing and the cover for dirt or corrosion. If necessary replace with a new guide and seal kit. In case of damage or excessive corrosion, the caliper must be replaced.

 The capped rubber sleeve (6d) will release itself from the carrier bore with cover (68d).

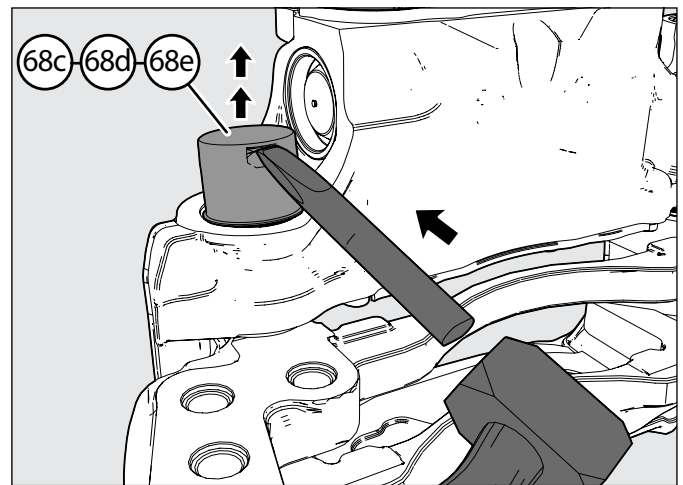

8.1.5 - Removal of cover (68c, 68d or 68e)

Removal of Cap (68a; Rubber Bush or 68f Double Roll Bearing)

8.1.6 Carefully remove cap (68a or 68f) from the guide pin (4a or 4f) using a suitable tool, avoid damaging the cap. Take care not to damage the rubber bush (6a) or Double Roll Bearing (6f).

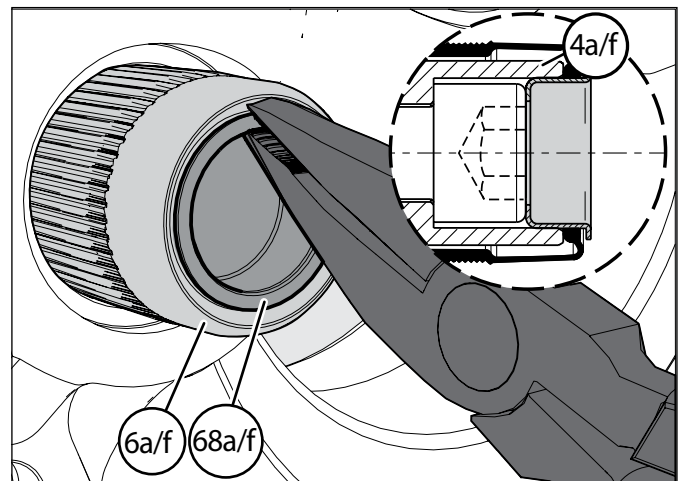



8.1.6 - Removal of cap (68a or 68f)

Removal of Caliper from Carrier

 Before removing the caliper bolts (39 and 40) ensure that the caliper (1) cannot move or fall when the caliper bolts are removed causing damage or injury.

8.1.7 Screw out the caliper bolts (39) and (40) (see Fig.).

 Never hold the caliper with your fingers between caliper and carrier - there is a risk of injury! Do not fasten any lifting device to the pad retainer (11), since this could be damaged.

 The opening or dismantling of the caliper is not authorised. Use only genuine Knorr-Bremse replacement calipers.

8.1.8 Remove caliper (1) from carrier (2).

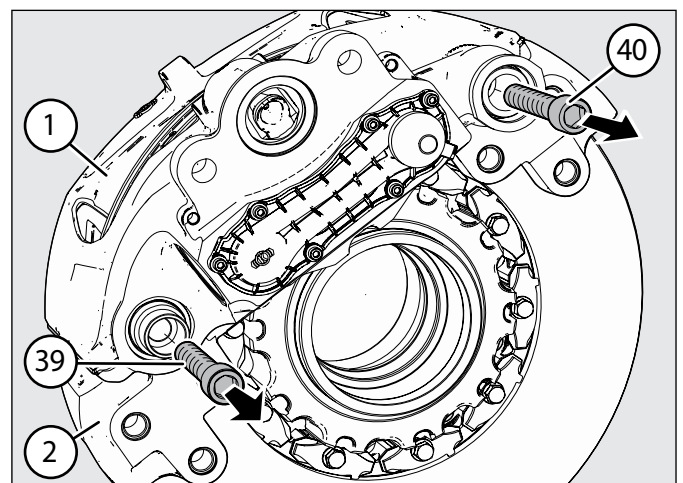

8.1.7 - Remove caliper bolts

8 Caliper Replacement

8.2 Fitting Caliper to Carrier - (Carrier assembled on vehicle)

Only use original Knorr-Bremse replacement calipers!

8.2.1 The correct choice of caliper must be ensured by checking the part number on the identification label (arrow **X**) (see also Section 1.2).

Note: The replacement caliper includes seals and guide pins as well as bolts and bushes for fitting the caliper to the carrier. Brake pads and wear sensors are not included.

If the replacement caliper is equipped with a potentiometer, then the connection must be made using the appropriate mating plug - refer to vehicle manufacturer's recommendations.

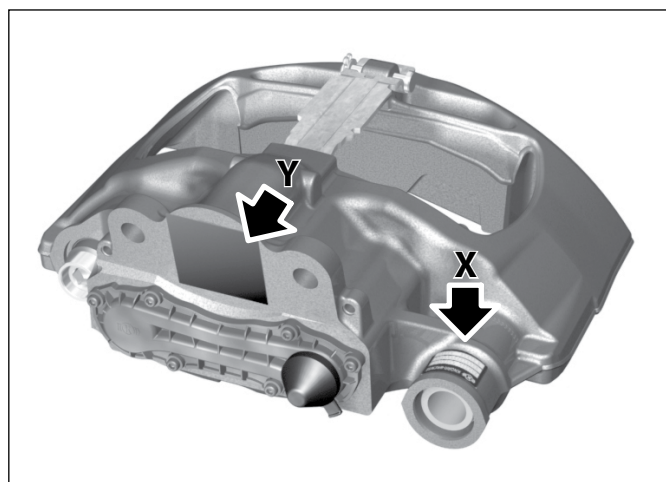

8.2.1 - Note identification label, remove adhesive tape

The caliper guide sleeves should be overhauled with the respective guide and seal kit (see Section 9 and 10), or the caliper replaced with the compatible rationalised caliper.

! The guide pins (4) and (5) as well as the caliper bolts (39) and (40) are highly stressed items. They must be replaced whenever the caliper (1) is removed from the carrier (2).

! Never hold the caliper with your fingers between caliper and carrier - there is a risk of injury! Do not fasten any lifting device to the pad retainer (11), since this could be damaged.

8.2.2 Lightly grease guide pins (4 and 5).

8.2.3 For bearing variant (68a; rubber bush) insert the guide pins from inside the caliper to the outside for both fixed and floating bearings.

8.2.4 For bearing variant (68b; open bearing, 68c and 68e; metal guide sleeve and 68d; capped rubber sleeve) insert the guide pins from inside the caliper to the outside for both fixed and floating bearings (see also Section 9.5 and 9.6).

8.2.5 For bearing variant (68f) the guide sleeve is already pre-installed as part of the Double Roll Bearing.

8.2.6 Check that the inner boot (9) and ring (58) sit correctly on the guide pin (4 and 5) (see Fig.), (see also Section 9.5 and 9.6).

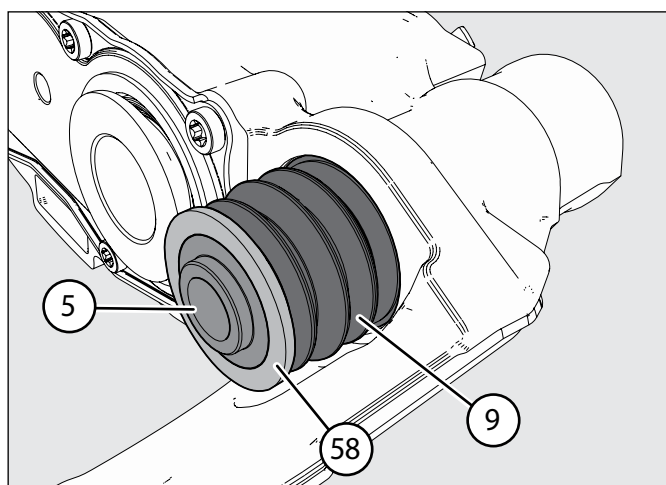

8.2.6 - Check inner boot and ring

8 Caliper Replacement

 Screw threads and tapped holes must be clean and dry (free of lubrication and residuals of pre-applied adhesive).

8.2.7 Place caliper (1) onto the carrier (2) and insert the caliper bolts (39) and (40). Tighten bolts to 180 Nm, then tighten by a further 90° (**use only new parts**) (see Fig.).

8.2.8 Check that the caliper slides easily on the guide pins. (see Section 5.3).

8.2.9 Fit brake pads (12) (see Fig. and Section 6.2).

8.2.10 If present, remove plastic cover or adhesive tape in the area of the actuator attachment from the replacement caliper (see Fig 8.2.1 arrow **Y**).

8.2.11 Fit brake actuator (18) (see Fig. and Section 11.2 or 11.4).

8.2.12 Check adjuster function (see Section 5.2).

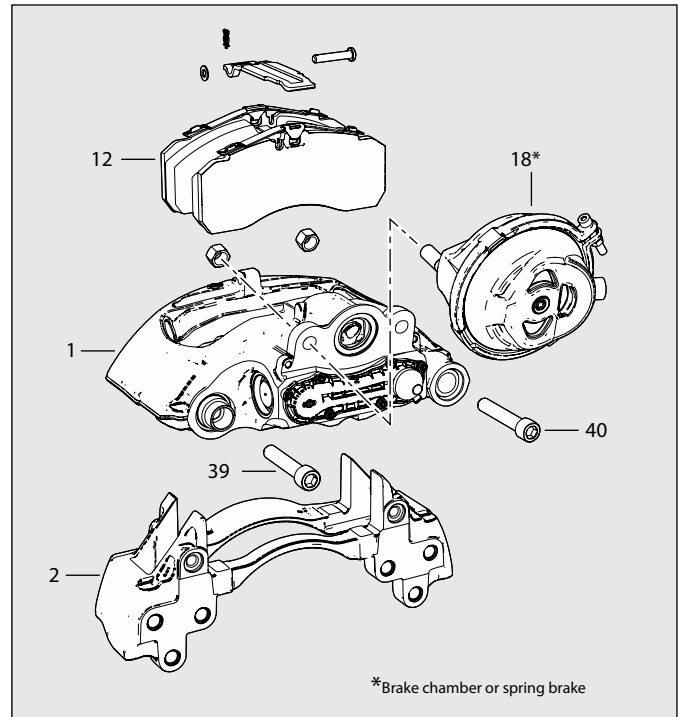

8.2.7 - 8.2.11 - Fit caliper onto carrier, tighten caliper bolts , fit brake pads, fit brake actuator

Fitting of Cover Variants

 Fitting of covers can only be done after the caliper has been fully bolted to the carrier (see Section 8.2).

Cover Variant (10) - Fixed Bearing Side

Before fixing the cover (10), slide the caliper as far as possible towards the outside of the vehicle and hold in position.

Caliper bores and cover must be clean and free from lubrication.

8.2.13 Clean the new cover (10) and the interior of the press-in tool (N) and insert the cover (10) into tool (N) as shown (see Fig.).

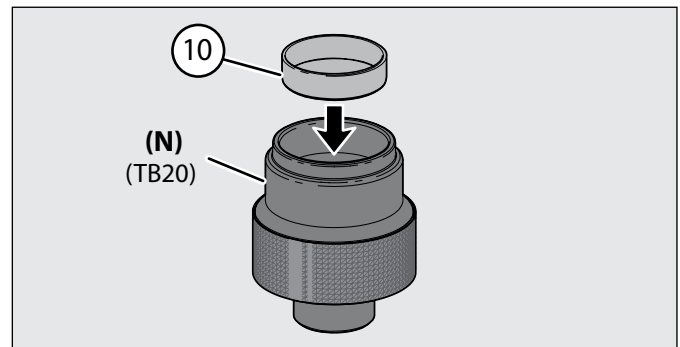

8.2.13 - Insert cover into tool (N)

8.2.14 Check the plane surface of caliper bore is clean and not damaged (see arrow) as well as the sealing surface for the cover (10). Position the press-in tool (N) including cover (10) squarely and check it sits correctly as shown (see Fig.).

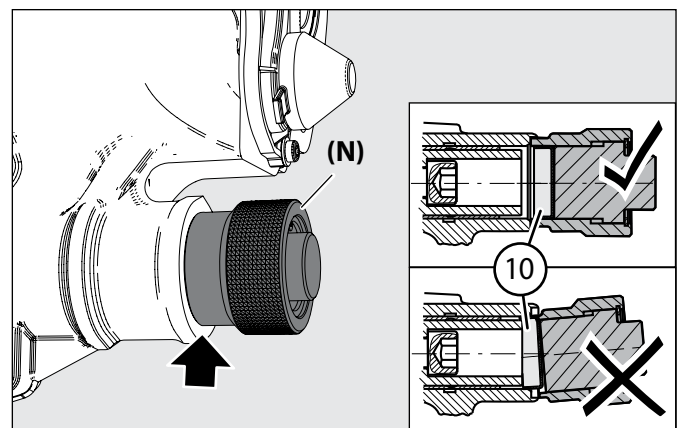

8.2.14 - Press-in tool (N) with cover in position on the plane surface of the caliper

Note: Do not tilt the tool when assembling the cover (10)!

8 Caliper Replacement

 The inner boot (9) must be in a compressed condition otherwise the caliper's freedom of movement will be limited.

8.2.15 Press the mandrel of the press-in tool (N) firstly by hand until it stops, then, using a hammer on the mandrel, insert the cover to the end stop (see Fig.).

Note: After fitting the new cover (10), ensure that it protrudes **2 mm** from the plane surface of the caliper (see Fig.).

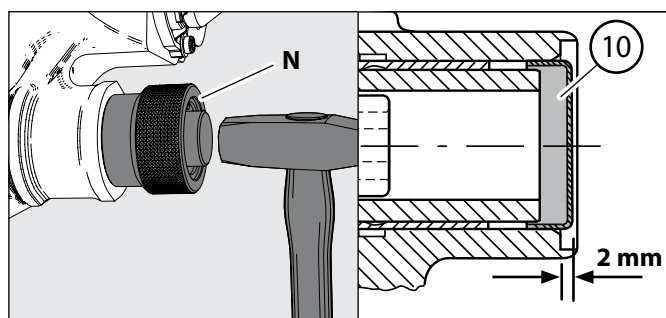

8.2.15 - Fitting cover to stop, final position protruding 2 mm

Cap (68a; Rubber Bush or 68f; Double Roll Bearing) - Floating Bearing

8.2.16 Fit the cap (68a/f) using tool (O) and a hammer. Force the cap into the guide pin (4a/f) until firmly seated. The seal is achieved by the compression of the lip of the rubber bush (6a) or Double Roll Bearing between (68f) and the guide pin (4a/f) (see Fig.).

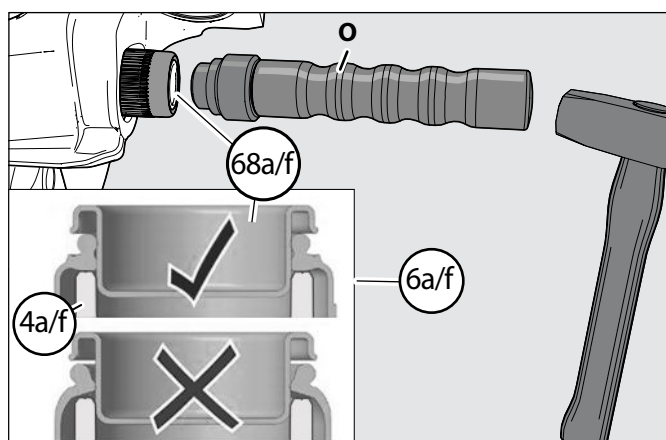

8.2.16 - Insert Cap into Guide Pin using tool (O)

Cover Variant (68c and 68e; Guide Sleeve) - Floating Bearing Side

Caliper bores and cover must be clean and free from lubrication.

8.2.17 Clean the new cover (68c or 68e) and the interior of the press-in tool (P) and insert the cover as shown (see Fig.).

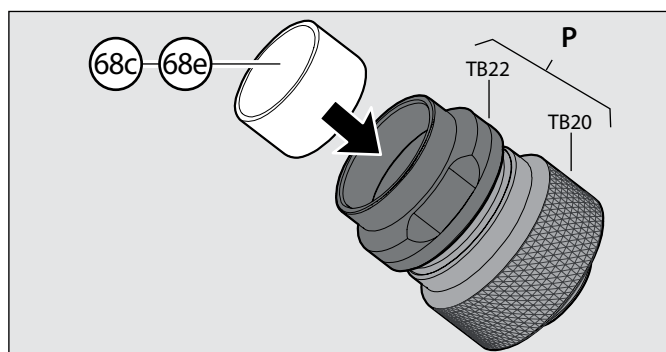

8.2.17 - Insert cover into tool (P)

8.2.18 Check the plane surface of caliper bore is clean and not damaged (see arrow). Position the press-in tool (P) including cover (68c or 68e) squarely and check it sits correctly as shown (see Fig.).

Note: Do not tilt the tool!

 The inner boot (9) must be in a compressed condition otherwise the caliper's freedom of movement will be limited.

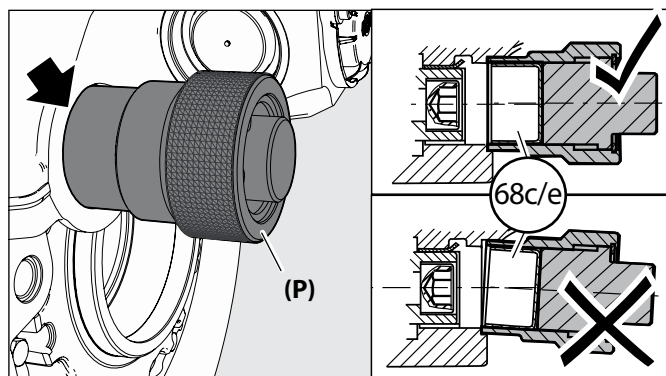

8.2.18 - Press-in tool (P) with cover in position on the plane surface of the caliper

8 Caliper Replacement

8.2.19 Press the mandrel of the press-in tool (P) firstly by hand until it stops, then, using a hammer on the mandrel, insert the cover to the end stop (see Fig.).

Note: After fitting the new cover (68c or 68e), ensure that it protrudes **15.5 mm** from the plane surface of the caliper (see Fig.).

Cover Variant (68d) - Floating Bearing Side

8.2.20 Push cover (68d) over capped rubber sleeve (6d) by hand. Place tool (R) onto cover (68d) and using a soft faced hammer, fit cover (68d) to the end stop (see Fig.).

Note: Use a soft faced hammer to avoid damage to tool (T08).

Fitting of Cover Variants with Caliper (1) and Carrier (2) Removed from the Vehicle:

8.2.21 Check caliper slides freely along the whole length of the guide pin arrangement (see Section 5.3).

8.2.22 Fix the carrier securely as shown i.e. bench vice, and push the carrier against the caliper to ensure the inner boots (9) are fully compressed (see Fig.).

 The inner boots (9) must be in a compressed state otherwise the caliper's freedom of movement will be limited.

8.2.23 Assembly of covers (10), (68a; rubber bush, 68b; open bearing, 68c and (68e; guide sleeve and 68d; capped rubber sleeve) can now proceed as previously described (see Section 8.2.12 - 8.2.19).

8.2.24 Fit the caliper complete with carrier onto the axle using new bolts. Note the required torque value.

Note: When fitting to the axle, refer to axle and/or vehicle manufacturer's recommendations

8.2.25 Fit brake pads (see Section 6.2).

8.2.26 Check adjuster function (see Section 5.2).

8.2.27 Fit brake actuator (18) (see Section 11.2 or 11.4).

8.2.28 Fit wheel (refer to axle and/or vehicle manufacturers recommendations).

After any work carried out on air disc brakes, a thorough testing of functioning and effectiveness is required. Note that during the start-up phase, new discs and/or pads usually have a bedding-in period before maximum performance is reached.

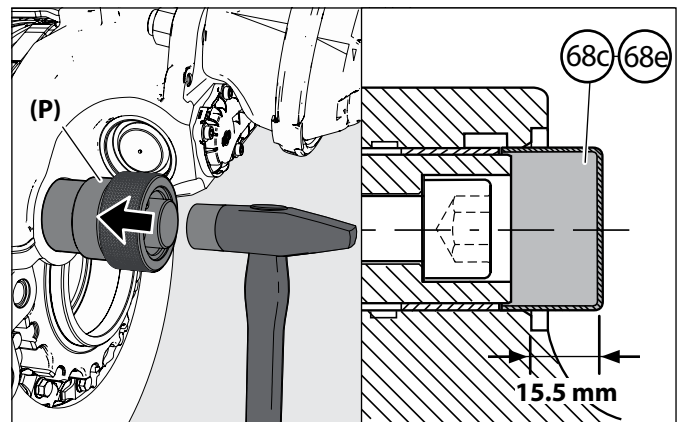

8.2.19 - Fit cover to stop, cover should protrude **15.5 mm**

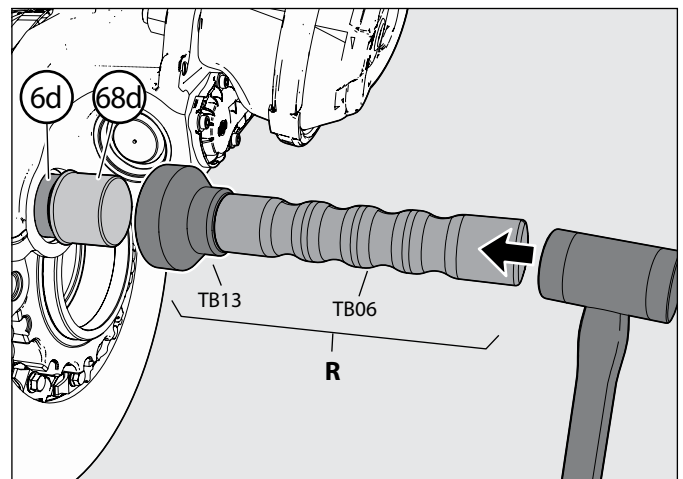

8.2.20 - Fitting cover (68d)

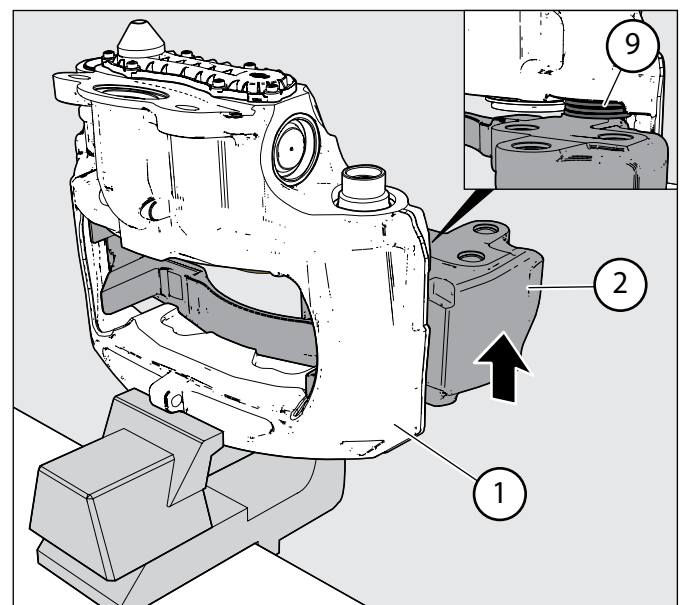

8.2.22 - Fix carrier, push carrier (2) against caliper (1)

9. Caliper Bearings Replacement

To replace the caliper bearings, all components of the fixed and floating bearing must be replaced by new components.

For ease of reference, each component of a tool is referred to by an identification number (see section 2.1).

9.1 Removal of Inner Boot (9)

- 9.1.1 Remove caliper (see Fig. and Section 8.1).
- 9.1.2 Remove ring (58) (see Fig.).
- 9.1.3 Pull out guide pins (4 and 5) (see Fig.).
- 9.1.4 Ease out inner boot (9) with a screwdriver or similar tool (see Fig.).
- 9.1.5 Check the sealing face of inner boot (9) for damage or corrosion (see Fig. arrow **A**).

Note: For caliper variants having an inner boot (9) on both bearing sides, the steps 9.1.1 - 9.1.5 are to be carried out on both sides.

9.2 Replacement of Brass Bush (7a or 7b) Fixed Bearing

For ease of reference, each component of a tool is referred to by an identification number (see section 2.1).

To replace the brass bush (7a or 7b) tool combinations **E**, **F** and **G** will be required (see Fig.).

Removal of Brass Bush (7a or 7b)

Prepare tool combination **E**.

The use of impact wrenches in conjunction with Knorr-Bremse service tools for pneumatic disc brakes is not permitted. These tools are not designed for use with an impact wrenches and may damaged the tools.

 **Risk of injury!** Knorr-Bremse assumes no liability for damages and injuries due to improper use, which may void any warranty claim for damaged Knorr-Bremse service tools in the process.

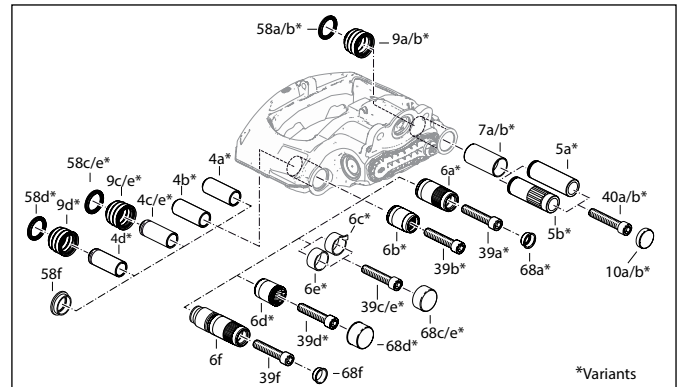

9.1.1 - 9.1.3 - Remove parts as described

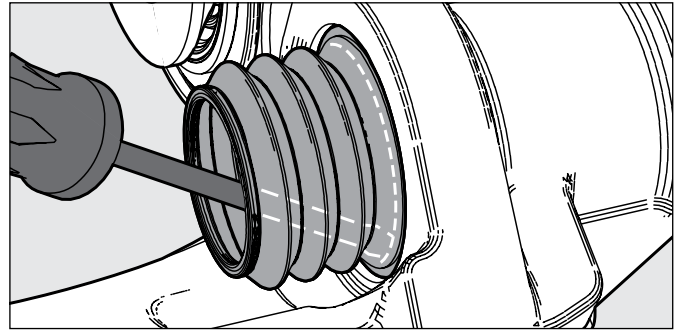

9.1.4 - Remove inner boot

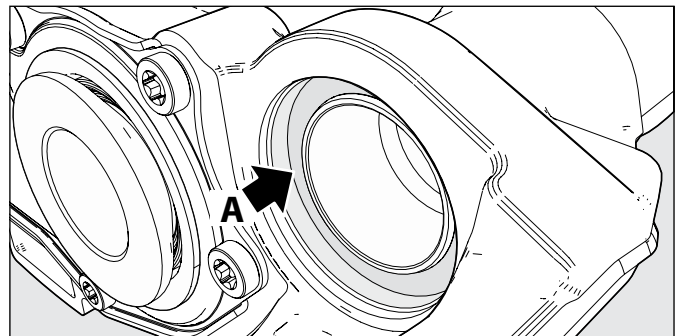

9.1.5 - Check for damage or corrosion

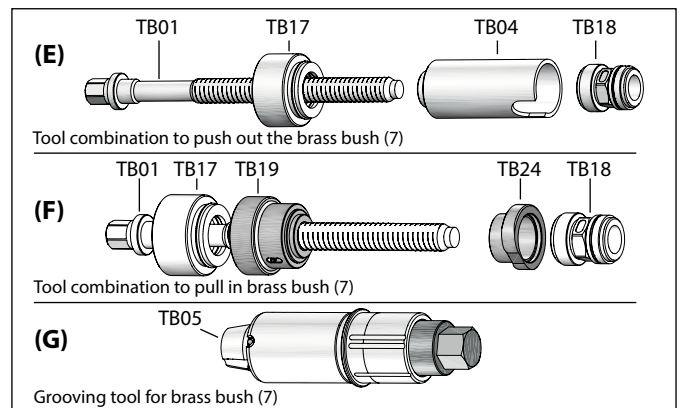

9.2 - Tool combinations for brass bush (7)

9 Caliper Bearings Replacement

9.2.1 Clean the surface are of the nut (TB18) on the bush. The area "B" must be grease free (see Fig.). The tool's nut is self-locking and therefore does not require any counter force to hold it in place.

9.2.2 Mount the tool combination as shown. Place Nut TB18 with the larger side onto the brass bush (7) (see Fig.).

Note: Take care that the nut TB18 is guided into the bush. Tool TB04 must lie flush on the surface (Arrow A) (see Fig.).

9.2.3 Turn the spindle (TB01) clockwise using a suitable tool e.g ratchet wrench, and carefully pull-out the brass bush (7).

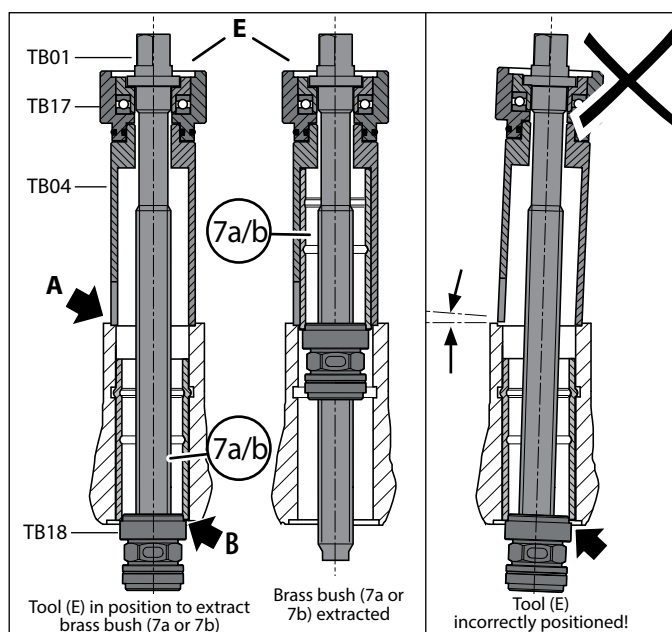

9.2.1 - 9.2.2 - Remove old brass bush using tool combination (E)

Fitting of Brass Bush (7a or 7b) Fixed Bearing

Use tool combination 'F'.

9.2.4 Clean the area of the bearing including the groove in the bore of the caliper.

9.2.5 Place the new brass bush (7) onto tool TB24 followed by the nut TB18 (with larger diameter end first) and screw into place. Mount the tool combination onto the caliper as shown. Take care that the flattened side of tool TB24 faces the caliper side wall with enough space to allow free travel movement.

9.2.6 Using a suitable tool e.g. ratchet wrench, turn the spindle clockwise to insert the brass bush (7) into the bearing bore until it stops against the tool.

Remove the tool combination 'F' from the caliper.

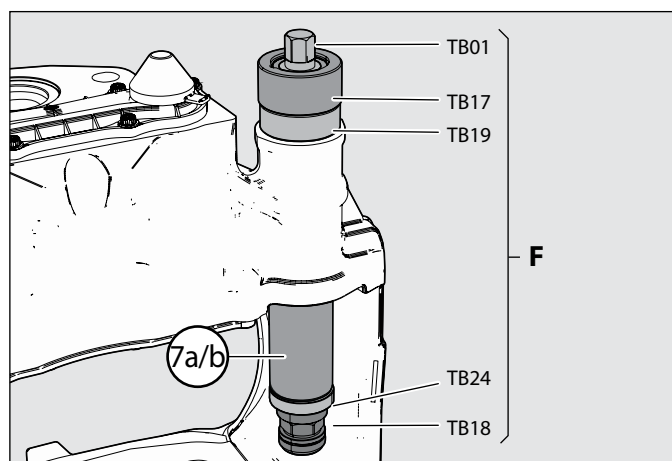

9.2.5 Positioning of tool (F) with new brass bush

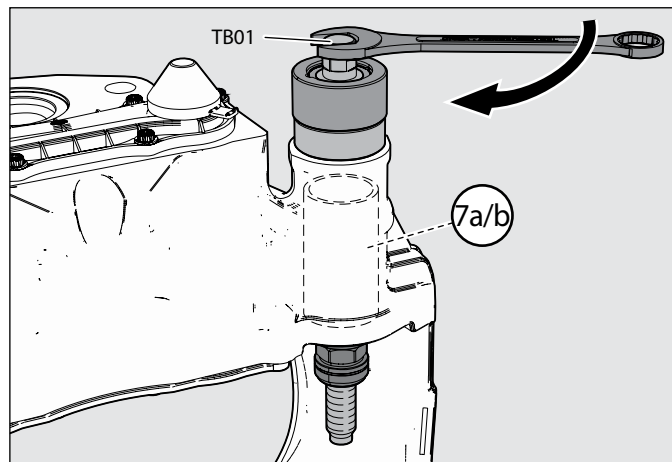

9.2.6 - Pull-in brass bush by turning (TB01)

9 Caliper Bearings Replacement

Locking Brass Bush (7a and 7b) in the Caliper

Use the grooving tool (**G**) **TB05**.

9.2.7 To prevent longitudinal displacement of brass bush (7), it must be grooved. The grooving tool '**G**' (TB05) is placed into the fixed bearing side from inside the caliper (1) into the brass bush (7). After it has been grooved once (as described below), tool '**G**' needs to be loosened, turned approx. **60°** and grooved again.

The tool has multiple markings on its outer circumference to evenly distributed the grooving. For this reason it is necessary to mark the caliper (see Fig.).

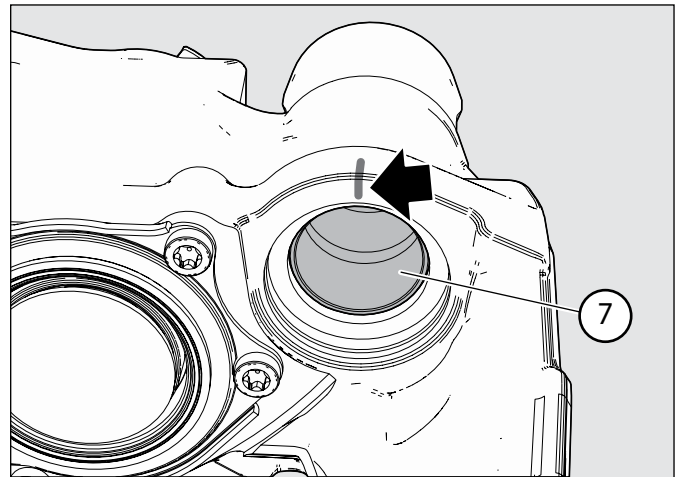

9.2.7 - Prevention of longitudinal displacement

9.2.8 Align the single groove on tool '**G**' with the mark on the caliper (see arrow '**A**'). Feed the grooving tool '**G**' into the Brass Bush (7) as far as it will go. Using a ratchet wrench turn the spindle clockwise until it stops. Make sure tool '**G**' lies flush on the brass bush (7).

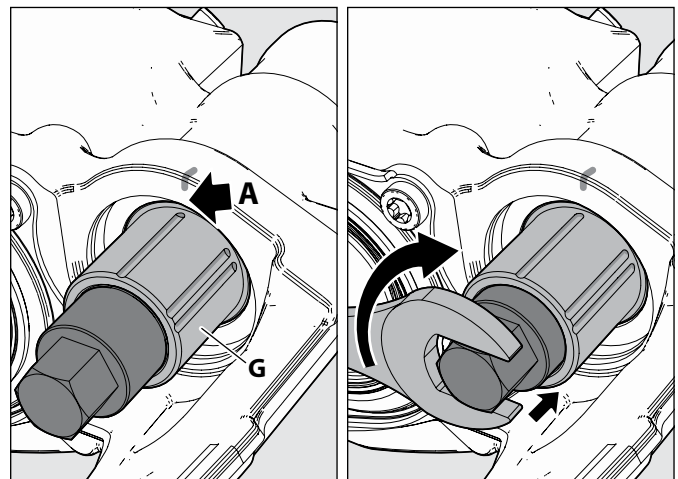

9.2.8 - Rotate 60°, repeat grooving

9.2.9 Loosen the spindle just enough so that it is possible to turn tool '**G**' approx. **60°** whilst still in position inside the brass bush (7a or 7b). Line up the double marker on the tool with the marker on the caliper and repeat the grooving process as previously described.

9.2.10 Loosen and carefully remove tool '**G**' from the brass bush (7a or 7b). If the tool cannot easily be removed, simply unwind the spindle further to retract the grooving pin which should allow the tool to be removed.

9.2.11 Check brass bush (7a or 7b) for burring, if present this should be carefully removed. Apply white grease (Part No. II14525 / K093430 / II32868) to brass bush (7a or 7b).

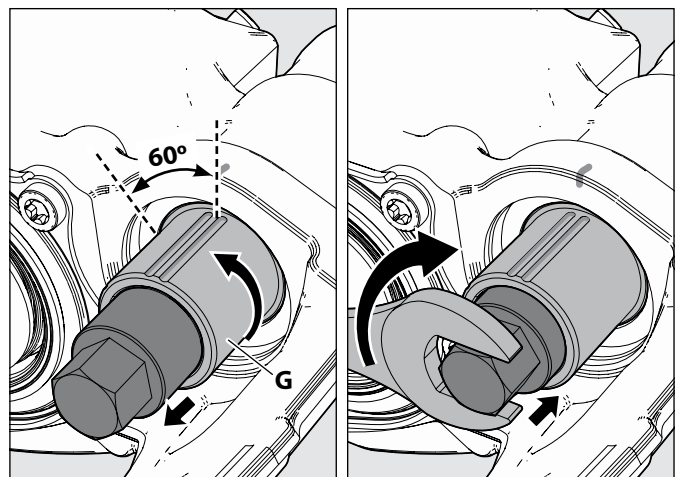

9.2.9 - Rotate tool '**G**' 60°, repeat grooving

9 Caliper Bearings Replacement

1....
2....
3....

9.3 Replacement of Guide Sleeve Variant (6a, 6b, 6c, 6d, 6e or 6f) Floating Bearing

For ease of reference, each component of a tool is referred to by an identification number (see section 2.1).

Guide sleeve variants are:

- 6a - Rubber bush
- 6b - Open bearing
- 6c and 6e - Guide sleeve
- 6d - Capped rubber sleeve
- 6f - Double Roll Bearing

The following tool combinations are used depending on the variant:

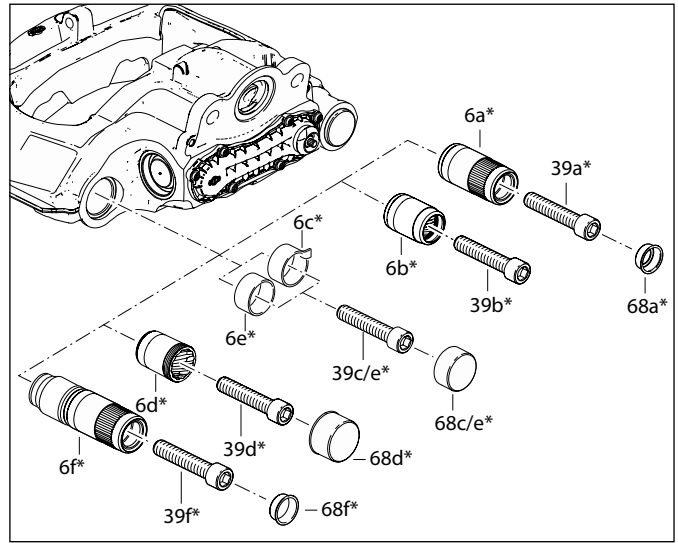

9.3 - Guide sleeve variants

To press-out the guide sleeve variants (6a, Rubber bush); (6b, Open bearing); (6c and 6e, Guide sleeve); (6d, Capped rubber sleeve), use tool combination (H) (see Fig.9.3a).

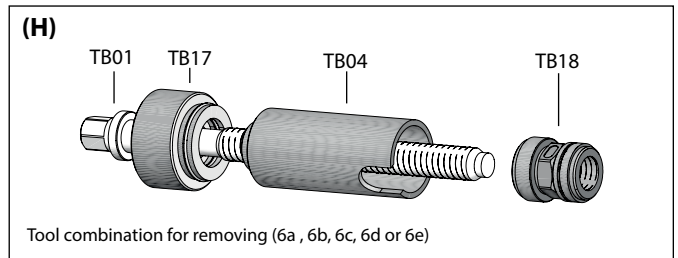

9.3a - Tool combination H

To press-out the double roll bearing (6f) use tool (U¹) for removal and (U²) for fitting (see Fig. 9.3b).

Note: The supplementary tool kit K209211K50 includes all the components for tool combinations (U¹) and (U²).

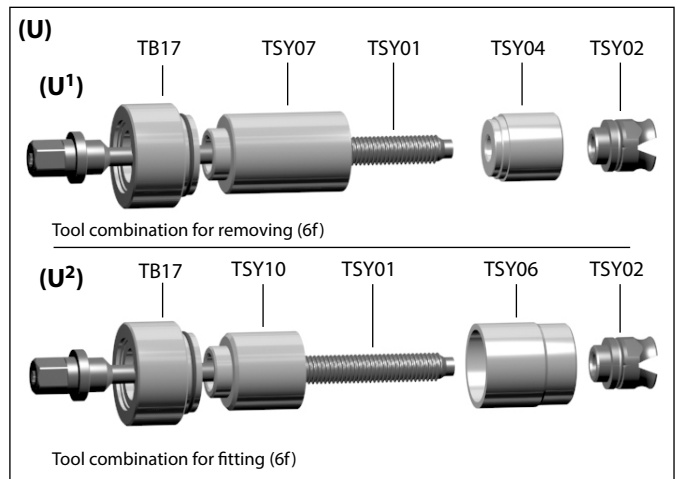

9.3b - Tool combination (U¹) and (U²)

9 Caliper Bearings Replacement

Removal of Floating Bearing Variants

9.3.1 Removal of Guide Sleeve (6a, or 6b) Floating Bearing

- 9.3.1.1 If present, remove guide pin (4a or 4b).
- 9.3.1.2 Clean the area around the bearing.
- 9.3.1.3 Place tool combination (H) into position.
- 9.3.1.4 Place the larger side of nut (TB18) onto spindle (TB01) and lightly tighten by hand (see Fig.).
- 9.3.1.5 Stabilise nut (TB18) using a ring-spanner 24 A/F and pull-out the rubber bush (6a) or open bearing (6b) by turning tool (TB01) using a ring-spanner (see Fig.).

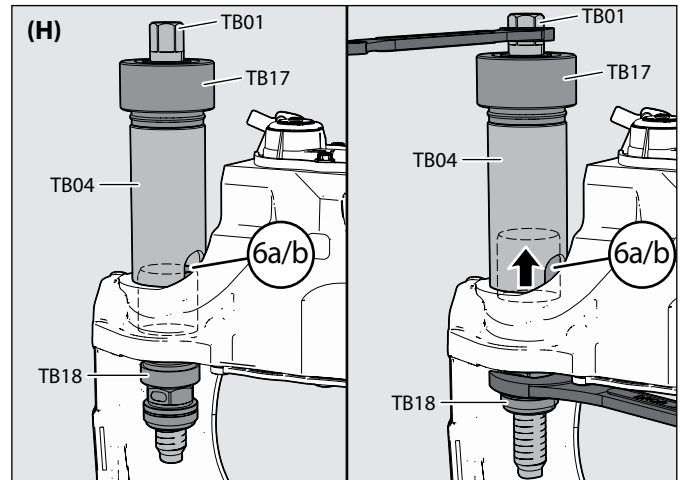

9.3.1.4 - 9.3.1.5 - Removal of guide sleeve (6a or 6b)

9.3.2 Removal of Guide Sleeve (6c and 6e; Guide Sleeve) Floating Bearing

- 9.3.2.1 Remove guide pin (4c or 4e).
- 9.3.2.2 Clean the area around the bearing.
- 9.3.2.3 **This procedure is only for guide sleeve (6c) with tab. For (6e) without tab go to 9.3.2.5.**

Use a suitable tool to separate the tab from the guide sleeve (6c) as described below:

The head of the screwdriver (or suitable tool) should be slightly narrower than the tab and placed as close as possible to its base (see Fig.).

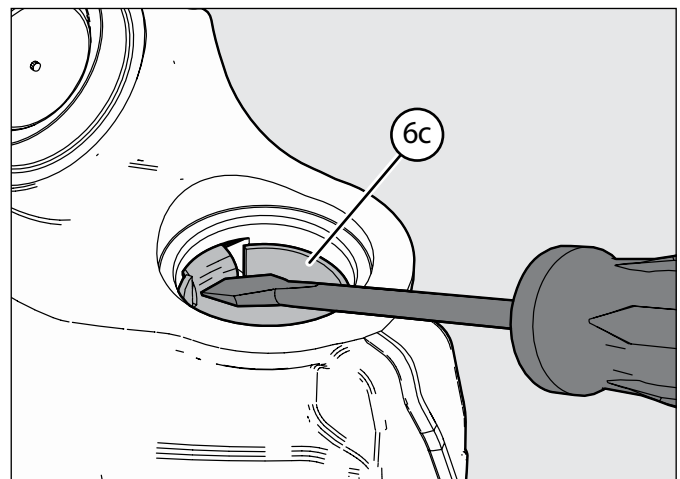

9.3.2.3 - 9.3.2.4 - Breaking off the tab from guide sleeve (6c)

- 9.3.2.4 separate the tab by striking the screwdriver in the direction of the tab.

Note: The tab can be found positioned either left or right in the caliper bore.

- 9.3.2.5 Clean the area around the bearing and brake pads.
- 9.3.2.6 Position the tool (H) as shown (see Fig.).
- 9.3.2.7 Place the larger side of nut (TB18) onto spindle (TB01) and lightly tighten by hand (see Fig.).

- 9.3.2.8 Stabilise nut (TB18) using a ring-spanner 24 A/F and pull-out the guide sleeve (6c) or (6e) by turning tool (TB10) using a ring-spanner (see Fig.).

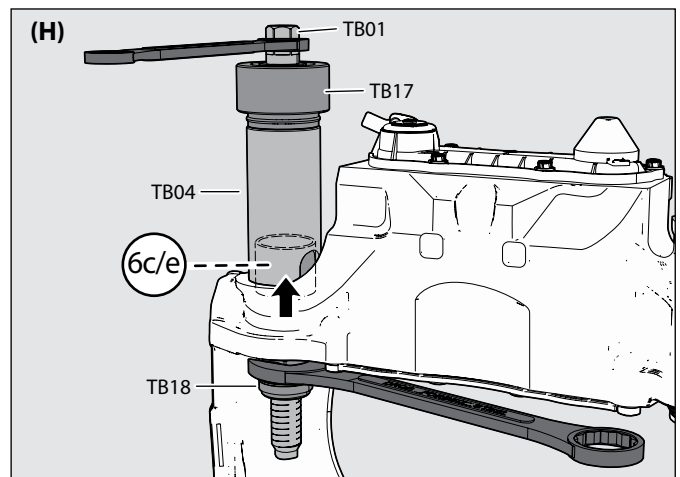

9.3.2.6 - 9.3.2.8 - Removal of guide sleeve (6c or 6e)

9 Caliper Bearings Replacement

9.3.3 Removal of Guide Sleeve (6d Capped Rubber Sleeve)

Note: Capped rubber sleeve (6d) is removed when the cover (68d) is removed. Therefore no removal procedure or special tool is required.

If this is not the case then follow the removal process as described in 9.3.2.

9.3.4 Removal of Double Roll Bearing (6f)

9.3.4.1 Remove the guide pin (6f.4) from the double roll bearing (6f) by pushing from the outside (arrow **A**) to inside (see Fig.).

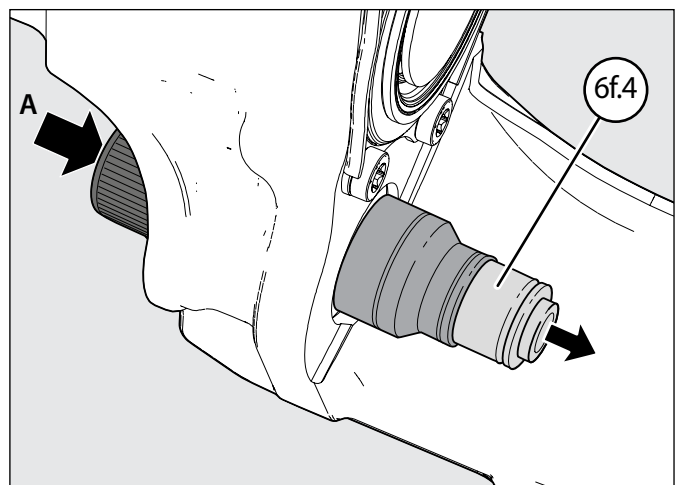

9.3.4.1 - Remove guide pin

9.3.4.2 Using a suitable tool, trim off inner-boot as close to the caliper as possible. Take care not to damage the caliper surface.

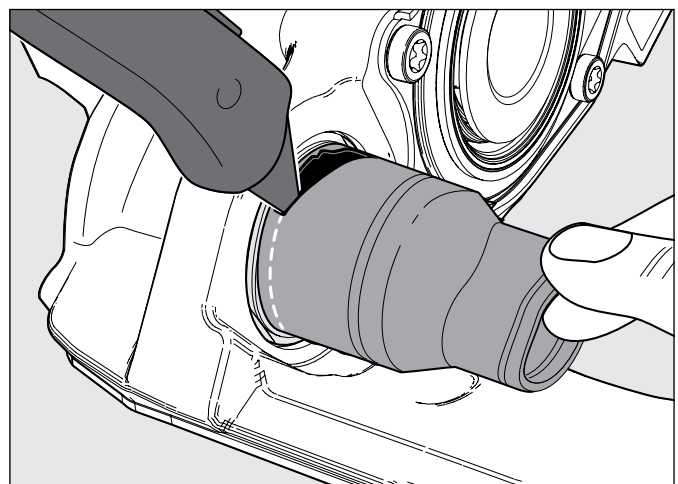

9.3.4.2 - Trim off inner-boot

9 Caliper Bearings Replacement

9.3.4.3 Position tool combination (**U**¹) on the floating bearing as shown (see Fig.).

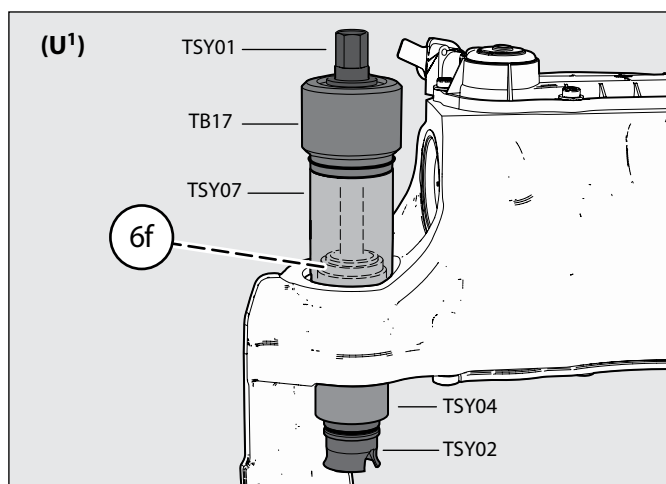

9.3.4.3 - Tool combination (**U**¹) in place

9.3.4.4 Pull-out the double roll bearing (6f) by turning spindle (TSY01) using a suitable tool (see Fig.).

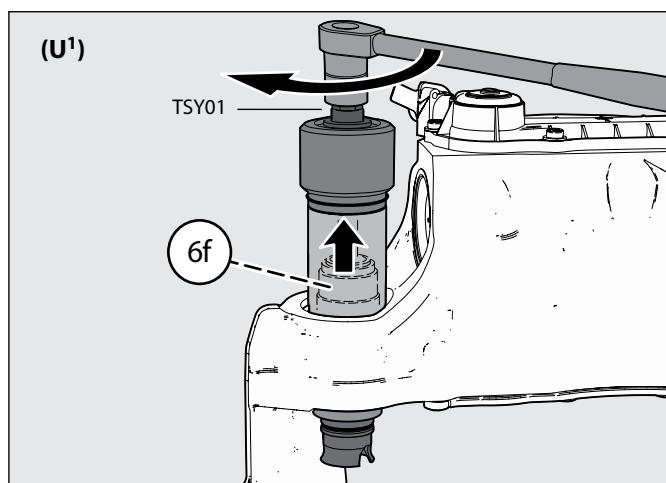

9.3.4.4 - Pull-out double roll bearing

Remove tool combination (U**¹).**

9 Caliper Bearings Replacement

Fitting of Floating Bearing Variants

9.3.5 Fitting of Guide Sleeve (6a Rubber Bush or 6b Open Bearing) Floating Bearing

To fit guide sleeve (6a Rubber Bush or 6b Open Bearing) use tool combination (K).

9.3.5.1 Check bore for corrosion and clean.

9.3.5.2 Push rubber bush (6a) or open bearing (6b) into (TB16) of tool (K) (see Fig.).

9.3.5.3 Place tool (K) with assembled rubber bush (6a) or open bearing (6b) in position on the caliper as shown (see Fig.).

9.3.5.4 Place the smaller side of nut (TB18) onto spindle (TB01) and lightly tighten by hand (see Fig.).

Note: Take care not to tilt the rubber bush (6a) or open bearing (6b) when winding in.

9.3.5.5 Stabilise nut (TB18) using an open spanner 24 A/F and using a torque wrench turn (TB01) to pull-in the rubber bush (6a) or (6b) until it stops (see Fig.).

The torque value of **23 Nm** must be observed (see fig.). If the torque is **<4 Nm** or **> 23 Nm**, the brake caliper must be replaced.

9.3.5.6 Remove tool (K).

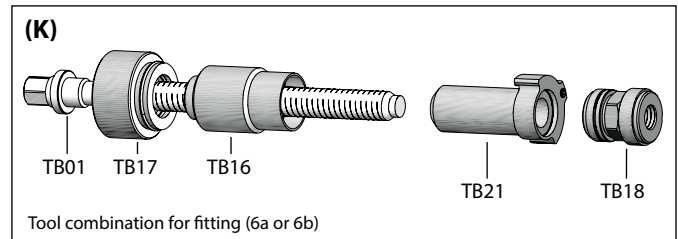

9.3.5 - Tool combination (K)

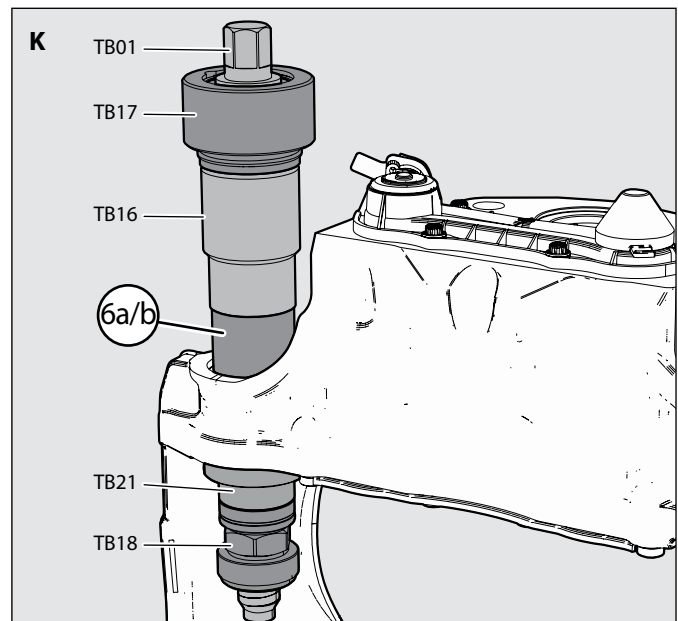

9.3.5.2 - 9.3.5.4- Rubber bush and tool combination (K) in situ

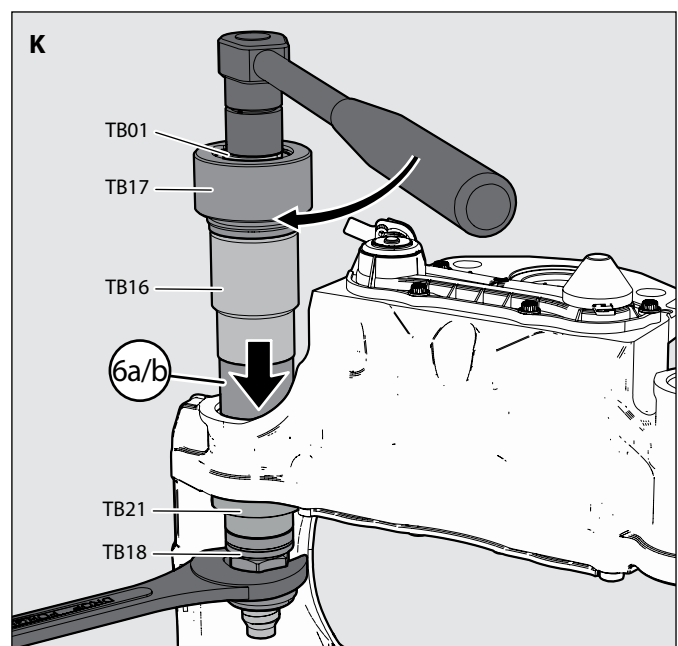

9.3.5.5 - Pull-in guide sleeve

9 Caliper Bearings Replacement

9.3.5.7 Check that the metal ring of the rubber bush (6a) or open bearing (6b) does not move (see Fig. arrow A).

 When checking for movement, ensure that the sealing elements are not damaged.

9.3.5.8 Grease inside the rubber bush (6a) or open bearing (6b) with white grease (Part No. II14525, K93430 or II32868).

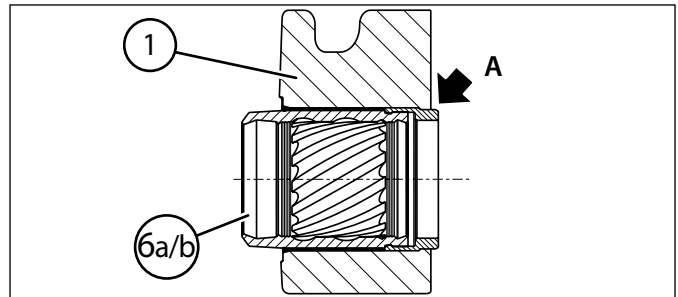

9.3.5.7 - Check metal ring of guide sleeve

9.3.6 Fitting of Guide Sleeve (6c or 6e)

To fit guide sleeve (6c or 6e) use tool combination (L).

9.3.6.1 Place guide sleeve (6c or 6e) into the caliper bore as shown. Fit tool combination (L) through the caliper bore and guide sleeve (6c or 6e) (see Fig.).

9.3.6.2 Place the small end of the nut (TB18) onto the spindle (TB01) and lightly tighten by hand.

Note: the position of the flat side of tool (TB24) should face the caliper wall.

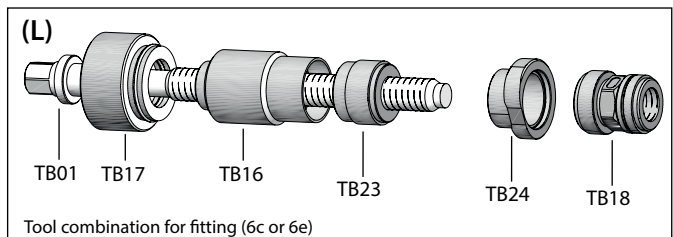

9.3.6 - Tool combination (L)

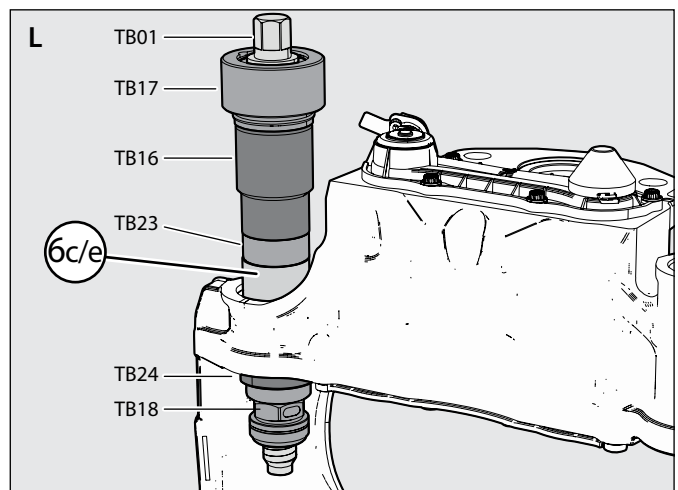

9.3.6.1 - 9.3.6.2 - tool combination (L) in position

9.3.6.3 Stabilise spindle (TB01) using a ring spanner on (TB18). Using a torque wrench turn the spindle (TB01) to pull-in the guide sleeve (6c oder 6e) until it stops (see Fig.). The torque value of **9 Nm** must be observed (see fig.). If the torque is **<2 Nm** or **> 9 Nm**, the brake caliper must be replaced.

Remove all assembly tools.

9.3.6.4 Apply white grease (Part. No. II14525, II32868 or K093430) to the inside of guide sleeve (6c oder 6e).

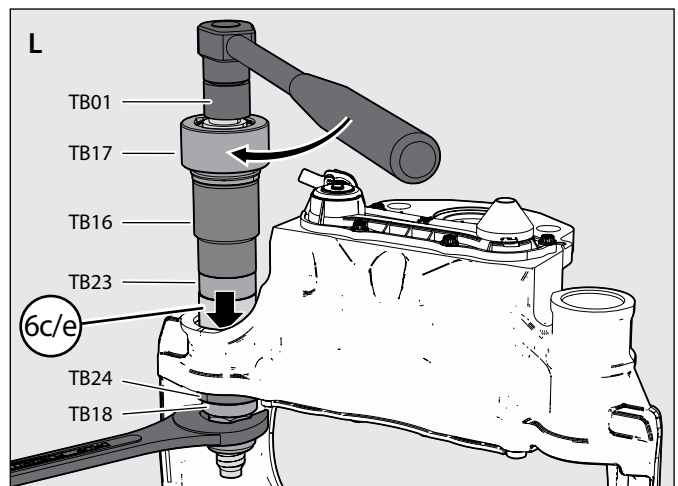

9.3.6.3 - Pull-in guide sleeve

9 Caliper Bearings Replacement

9.3.7 Fitting of Guide Sleeve (6d - Capped Rubber Sleeve)

To fit guide sleeve (6d - Capped Rubber Sleeve) use tool combination (M).

9.3.7.1 Clean the area around the bearing.

9.3.7.2 Prepare the first part of the tool combination (M) (TB01+TB17+TB19) and place capped rubber sleeve (6d) onto tool (TB19).

9.3.7.3 Bring this first part of tool (M) into position as shown (see Fig.).

9.3.7.4 Place (TB24), (TB21) and the smaller side of nut (TB18) onto spindle (TB01) and lightly tighten by hand.

9.3.7.5 Stabilise the spindle (TB01) by holding a ring spanner on nut (TB18). Using a torque wrench turn (TB01) to push (6d) until it stops (see Fig.).

The torque value of **13 Nm** must be observed (see fig.). If the torque is **<2 Nm** or **> 13 Nm**, the brake caliper must be replaced.

9.3.7.6 Remove tool (M).

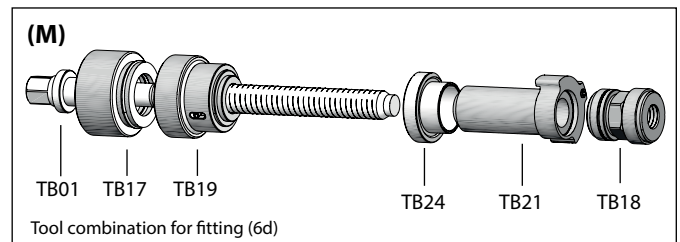

9.3.7 - Tool combination (M)

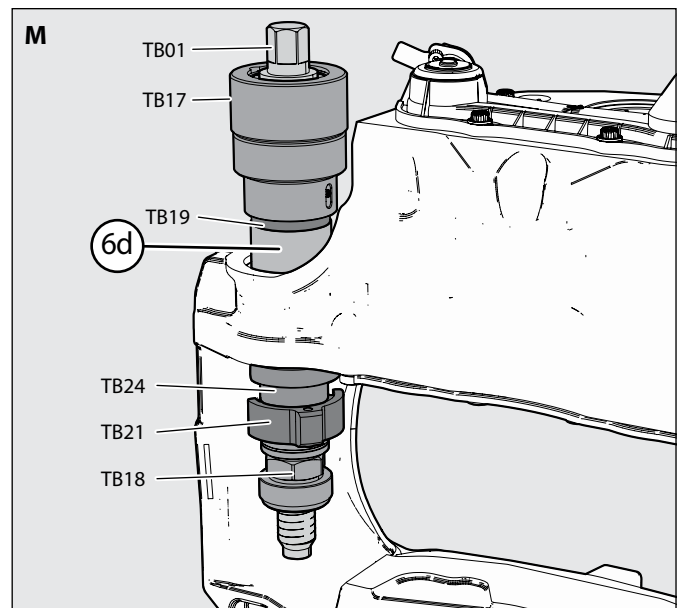

9.3.7.3 - 9.3.7.4 - Tool combination (M) in position

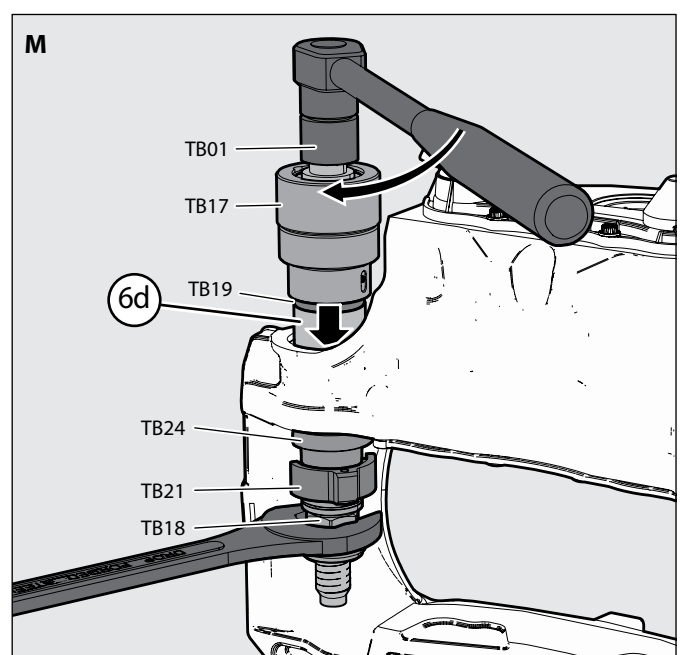

9.3.7.5 - Wind down guide sleeve until it stops

9 Caliper Bearings Replacement

1....
2....
3....

9.3.7.7 Check that the metal ring of the capped rubber sleeve (6d) cannot move (see Fig. arrow **A**).

 When checking for movement, ensure that the sealing elements of the capped rubber sleeve (6d) are not damaged.

9.3.7.8 Grease inside the capped rubber sleeve (6d) with white grease (Part No. II14525, K93430 or II32868).

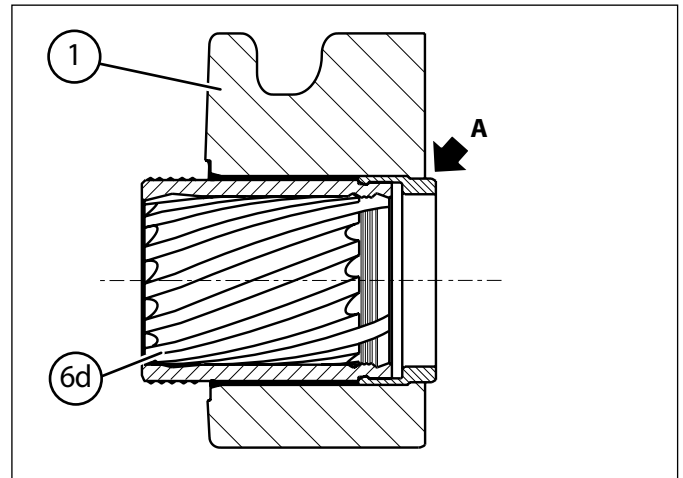

9.3.7.7 - Check metal ring of capped rubber sleeve

9.3.8 Fitting of Double Roll Bearing (6f)

9.3.8.1 Remove protective plug (see Fig. arrow **A**). Making sure the protective sleeve is still fitted (see Fig. arrow **B**), place double roll bearing (6f) carefully into the caliper bore.

9.3.8.2 Place tool (**U²**) as shown through the double roll bearing (6f) and hand tighten in place.

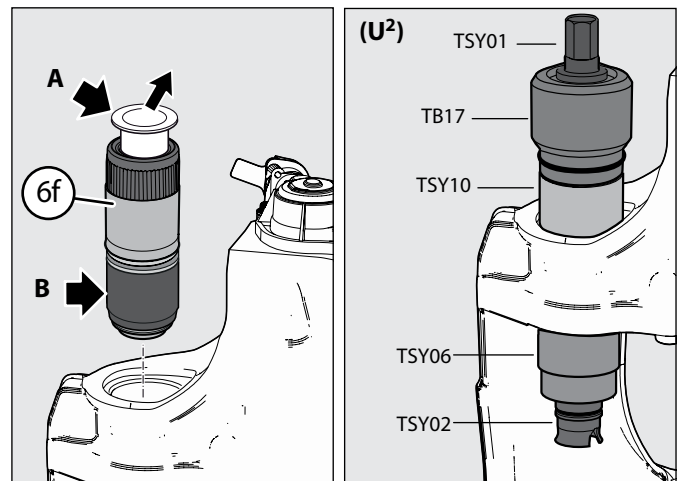

9.3.8.1 - 9.3.8.2 - Place (6f) into the caliper bore and attach tool combination (**U²**)

9.3.8.3 Using a torque wrench (**max. 23 Nm**) turn spindle (TSY01) to pull-in double roll bearing (6f) (see Fig.).

 If the torque value is **< 4 Nm** or **> 23 Nm**, the caliper must be replaced.

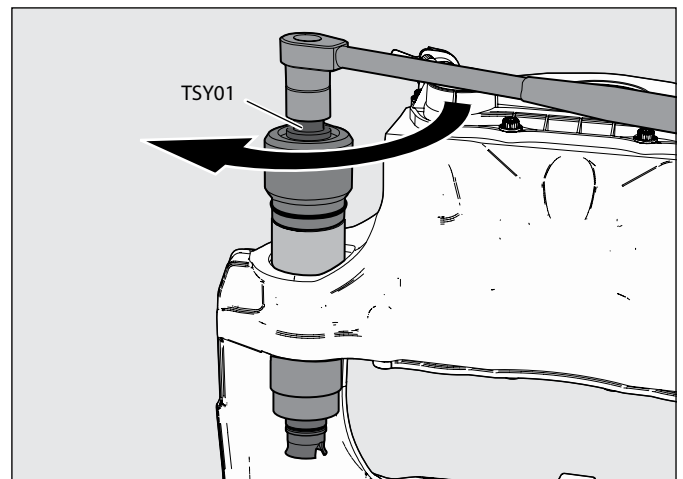

9.3.8.3 - Pull-in Guide sleeve (6f)

9 Caliper Bearings Replacement

9.3.8.4 Remove tool combination (**U²**) and protective sleeve (see Fig. arrow **B**).

 Dispose of protective plug and sleeve in accordance with environmental guidelines.

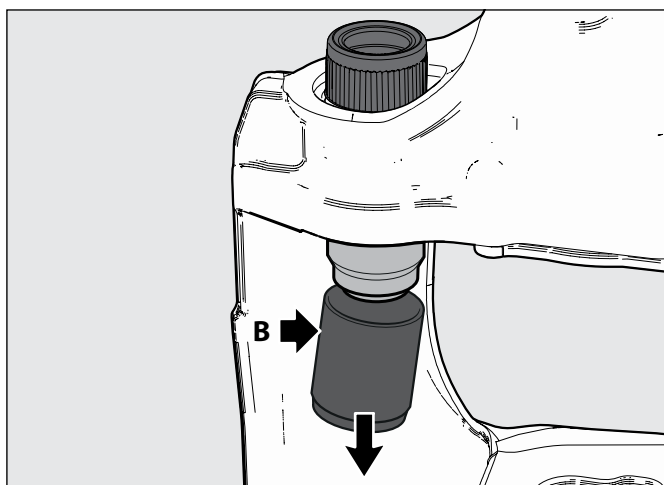

9.3.8.4 - Remove tools and protective sleeve

9.3.8.5 Fit lip of inner boot into the groove of guide pin, make sure it has fully engaged right round and is not twisted (see Fig. arrow **C**).

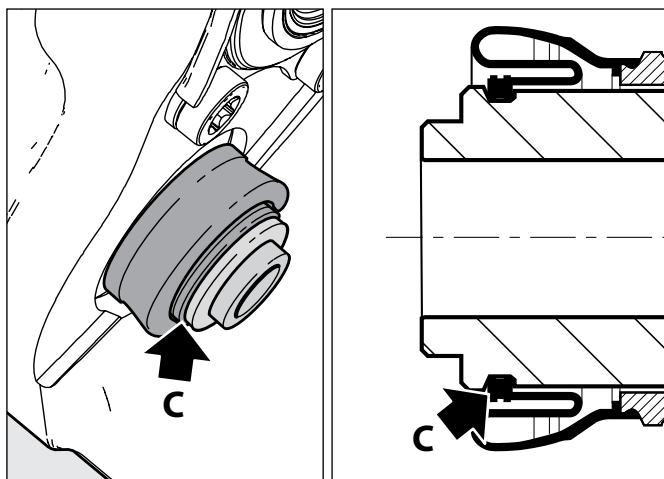

9.3.8.5 - Fit lip of inner boot into guide pin groove

9.3.8.6 Push on ring (58f) onto the double roll bearing to secure engagement of its inner boot on the guide pin (see Fig.).

 The smooth face of the ring i.e. flat side (arrow **D**), must face towards the brake carrier (see Fig.).

9.3.8.7 To fit brake caliper to carrier (see Section 8.2).

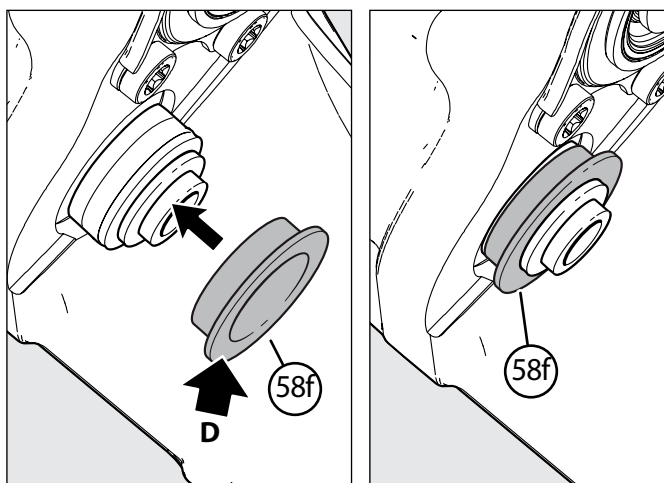

9.3.8.6 - Fit ring to secure inner boot

9 Caliper Bearings Replacement

9.4 Fitting of Inner Boot (9a or 9b) Fixed Bearing or (9c, 9d, or 9e) Floating Bearing

Note: The following steps **9.4.1 - 9.4.6 do not apply** to the floating bearing side if the double roll bearing (6f) variant is being fitted.

For ease of reference, each component of a tool is referred to by an identification number; a complete tool (containing one or more such components) has been given a letter code - see section 2.1.

9.4.1 To fit the inner boot (9a, 9b) on the fixed bearing side use the pull-in tool (**D¹**) containing (TB19).

To fit the inner boot (9c, 9d, 9e) on the floating bearing side use the pull-in tool (**D²**) containing (TB04).

Note: The following shows only the process for the fixed bearing side, but the assembly of the inner boot (9) is the same principle whether for the floating or fixed bearing side.

9.4.2 The contact surface of the boot (9) on the guide pin (5) and the caliper (1) must be clean and free of lubrication.

Check the sealing face of inner boot (9) for damage or corrosion (see Fig. arrow **A**).

9.4.3 Fit new inner boot (9) into sleeve (TB25) of tool (**D¹**). Make sure the rubber folds of the boot sit inside the tool (See Fig. arrow **B**).

9.4.4 Position sleeve (TB25) of tool (**D¹**) into the caliper bearing bore. Then attach the assembled sleeve (TB25) with inner boot (9), pulling-in firstly by hand (see Fig.).

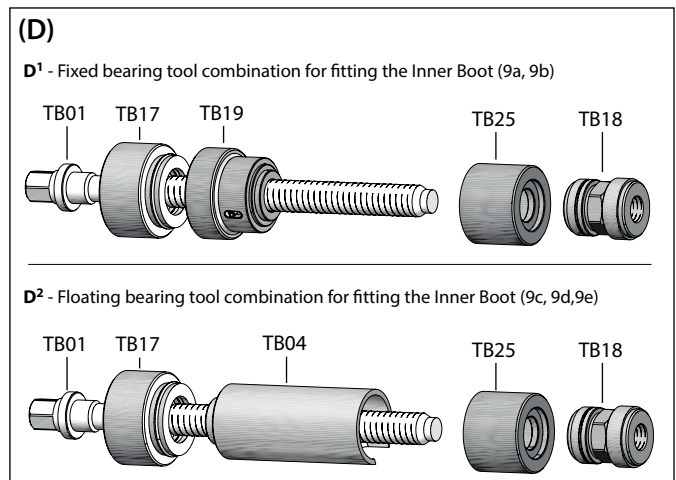

9.4.1 - Tool combination (**D¹** and **D²**)

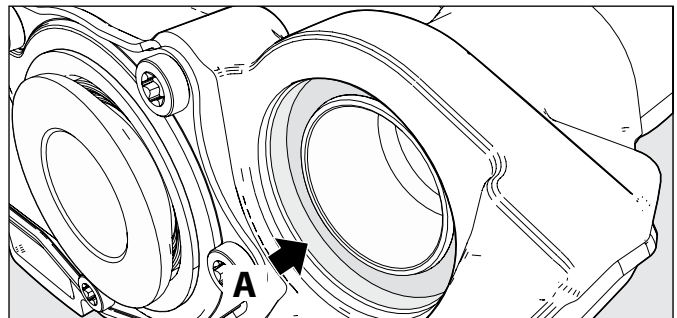

9.4.2 - check for corrosion and damage

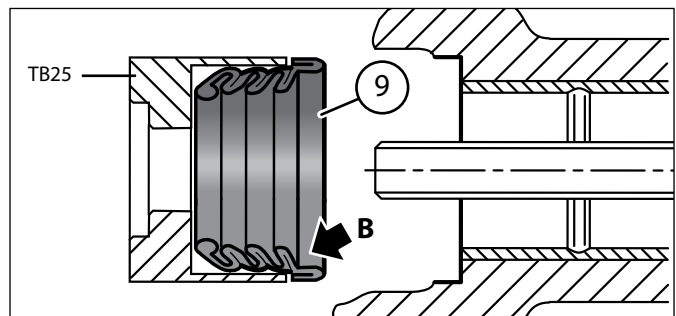

9.4.3 - Insert inner boot (9) in tool (TB25)

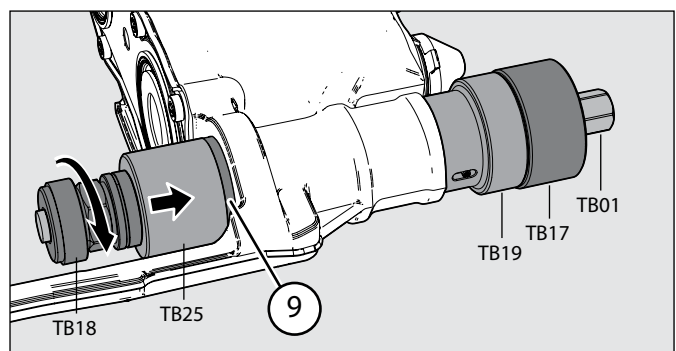

9.4.4 - Attach TB25 (with inner boot) and TB18 - tighten by hand

9 Caliper Bearings Replacement

9.4.5 Stabilise the spindle (TB01) by holding a ring spanner on nut (TB18). Using a torque wrench turn (TB01) to pull-in inner boot (9) until it stops with a maximum torque of **4 Nm** (see Fig.).

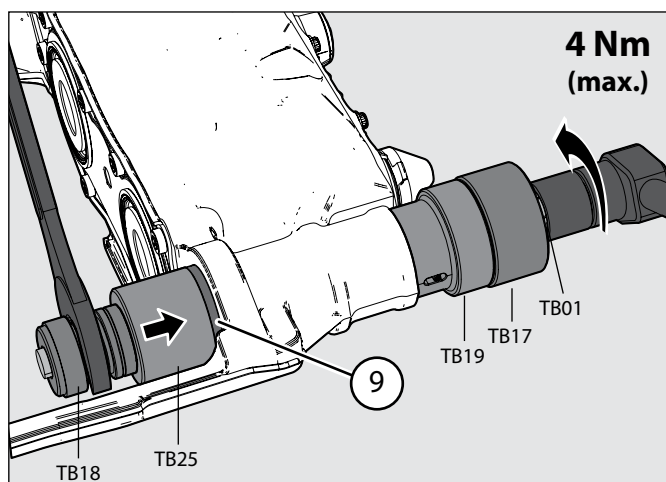

9.4.5 - Pull-in with max. **4 Nm**

9.4.6 Check correct fitment of inner boot (9) by carrying out a pulling test (see Fig.).

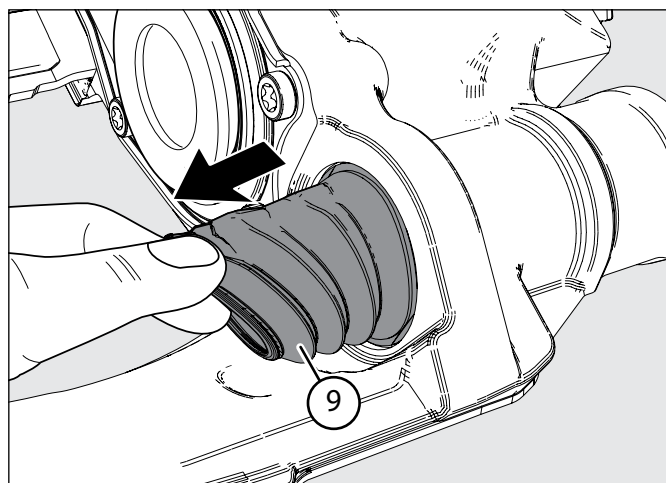

9.4.6 - Carry out pulling test on inner boot

9.5 Fitting of Guide Pin (5a or 5b) - Fixed Bearing

9.5.1 Completely cover inside of brass bush (7a or 7b) with white grease and in the area on the guide pin (5 or 5a) as shown (Part No. II14525 , K093430 or II32868). Make sure the grease pockets are filled (see Fig.).

9.5.2 Fit guide pin (5a or 5b) from outside the caliper into the caliper bore (see Fig.).

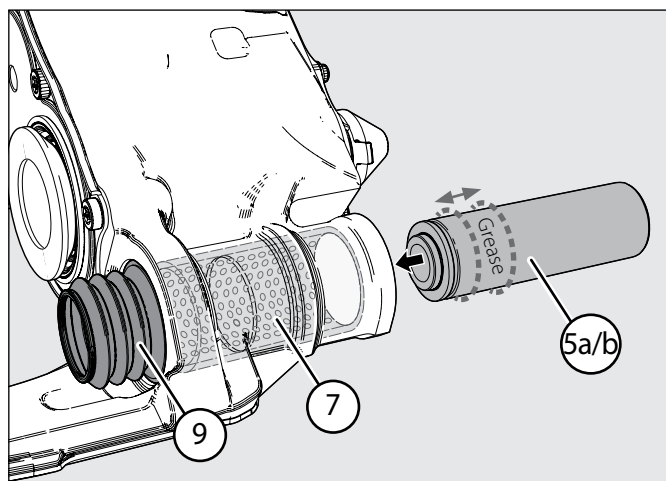

9.5.1 - 9.5.2 - Fit guide pin from outside

9 Caliper Bearings Replacement

Note: The following steps **9.6 - 9.7** do not apply to the double roll bearing (6f) on the floating bearing side (it already contains its own guide sleeve variant).

9.6 Fitting of Guide Pin (4a, 4b, 4c, 4d or 4e) Floating Bearing

9.6.1 Grease guide sleeve (6a, 6b, 6c, 6d or 6e) with white grease (Part No. II14525 , K093430 or II32868).

9.6.2 With Bearing Variant (6a; Rubber Bush) and (6b; Open Bearing):

9.6.2.1 Fit guide pin (4a or 4b) from inside the caliper into the caliper bore (see Fig.).

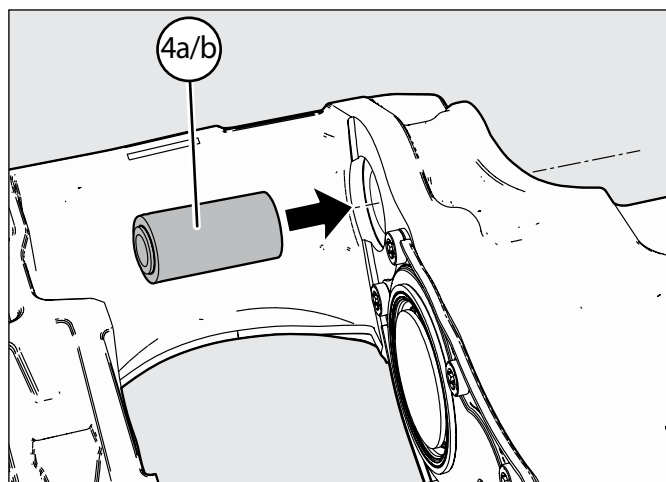

9.6.2.1 - Fit guide pin from inside caliper

9.6.3 With Bearing Variant (6c and 6e; Guide Sleeve):

9.6.3.1 Fit guide pin (4c, 4d or 4e) from outside the caliper into the caliper bore (see Fig.).

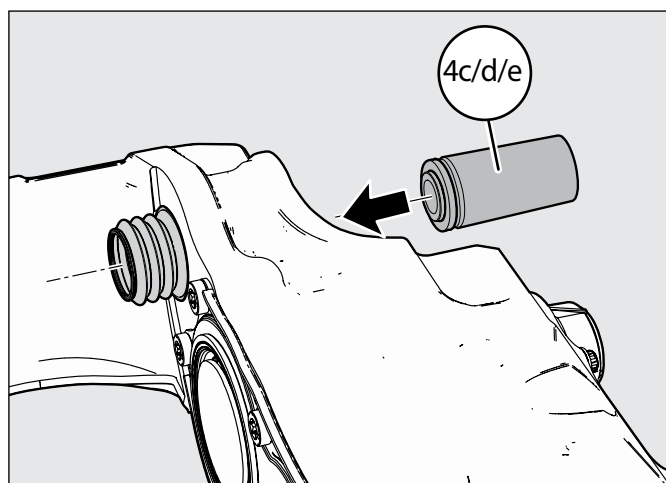

9.6.3.1 - Fit guide pin from outside caliper

9.7 Engage Inner Boot (9) into Guide Pin (4c, 4d or 4e) Floating Bearing or (5a or 5b) Fixed Bearing

9.7.1 The lip end of the inner boot (9) must engage in the groove of the respective guide pin variant (see Fig. arrow A).

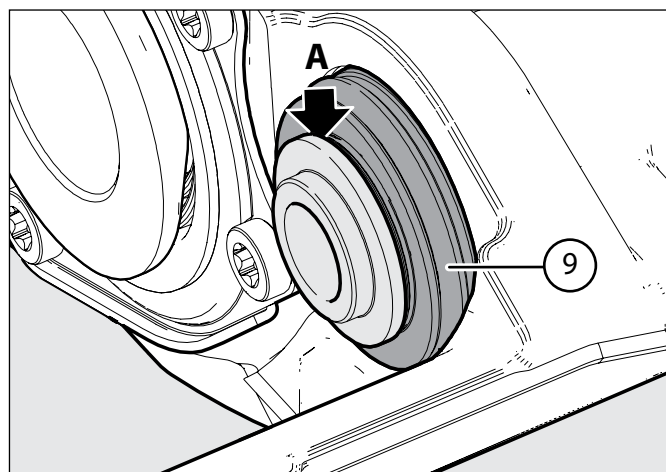

9.7.1 - Lip of inner boot engages in groove on guide pin (arrow A)

9 Caliper Bearings Replacement

9.7.2 Make sure the lip of inner boot (9) has fully engaged right round the guide pin and is not twisted (see Fig. arrow **B**).

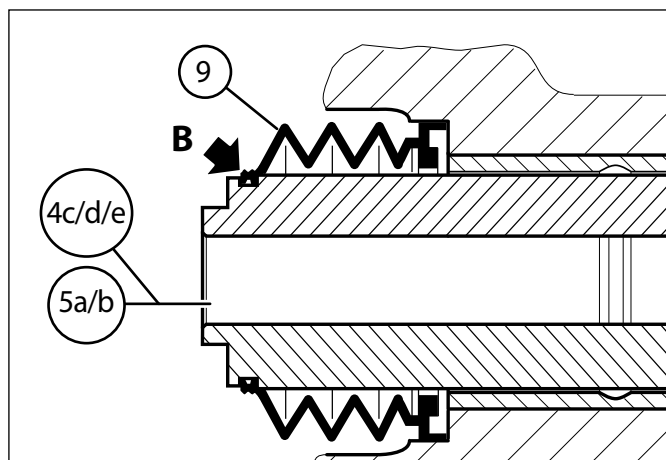

9.7.2 - Check complete engagement

9.7.3 Push on the ring (58) to secure engagement of inner boot (9) on guide pin (4 and/or 5) (see Fig.).

 The smooth face of the ring i.e. no lip (arrow **C**), must face towards the brake carrier i.e. away from inner boot (9).

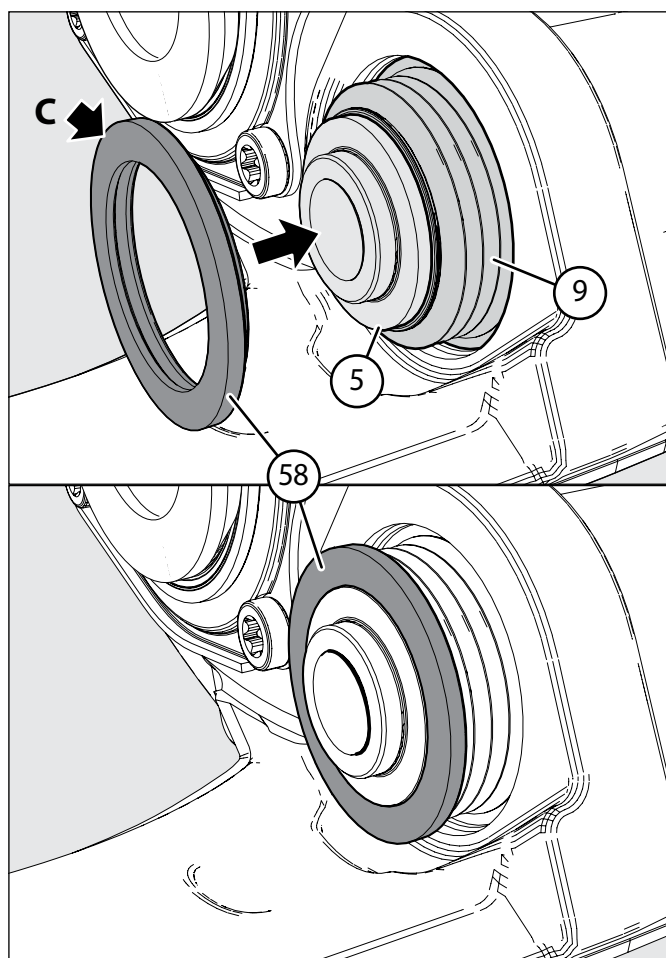

9.7.3 - Push on ring to secure boot in groove of guide pin

9.7.4 Fit brake caliper to carrier (see Section 8.2).

10. Carrier Replacement

Depending on the installation, it may be possible to remove the caliper from the carrier and replace the carrier in situ. Else it may be necessary or more convenient to remove the complete carrier/caliper assembly from the vehicle where it can be separated and the carrier replaced.

Note: The disc brake is very heavy, take great care in handling!

Do not fasten any lifting device to the pad retainer (11) since this can be damaged.



Use only new parts from the guide and seal kit when fitting the caliper to the carrier. This is not supplied with the caliper and must be ordered separately.

Note: The carrier is fitted to the vehicle according to the vehicle manufacturer's specifications and with bolts supplied by the vehicle manufacturer – they are not available from Knorr-Bremse.

See section 8 as applicable:

Either:

- 10.1 Remove caliper from carrier.
- 10.2 Replace carrier – ensure new bolts and correct torques are used. Note, bolts to fit the calliper to the axle are not supplied by Knorr-Bremse but from the vehicle manufacturer. Refer to the vehicle manufacturer's fitting instructions and torque values.
- 10.3 Refit caliper to carrier.

Or:

- 10.1 Remove the complete caliper/carrier assembly.
- 10.2 Replace carrier.
- 10.3 Refit the complete caliper/carrier assembly – ensure new bolts and correct torques are used.

11. Brake Actuator Replacement

Note: All references to brake actuators (brake chambers and spring brakes) in this section refer to Knorr-Bremse brake actuators. For other brake actuator manufacturers, follow their respective instructions.

11.1 Removal of Knorr-Bremse Brake Chamber

11.1.1 Disconnect air connection from brake chamber (18) – **take care, air connection must be free of air pressure!**

11.1.2 Unscrew brake chamber mounting nuts and remove brake chamber (18) (see arrows in Fig.).

 It is not allowed to reuse the nuts of the brake chamber (18).

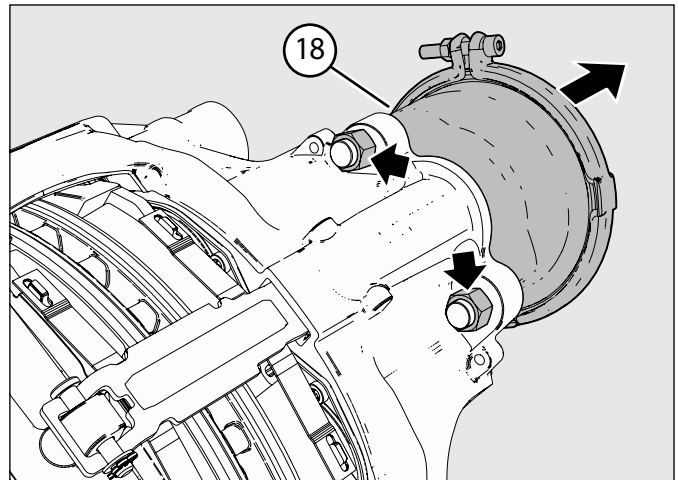

11.1.2 - Brake chamber removal

11.2 Fitting of Knorr-Bremse Brake Chamber

Note: New brake chambers (18) have drain plugs installed (see arrow **A**). Remove lowest plug (as viewed when brake chamber is installed). All other drain holes should be plugged (refer to the vehicle manufacturer's recommendations).

11.2.1 The sealing surface and the flange surface (see Fig. arrow **B**) must be:

- free from dust and corrosion
- free from damage
- flat

Take care that no dirt enters the brake caliper!

11.2.2 Before fitting the new brake chamber, the spherical cup (19) of the lever and the sealing surface of the caliper must be greased with white grease (Part No. II14525, K093430 or II32868).

 Do not use grease containing molybdenum disulphide. Use only actuators which are recommended by the vehicle manufacturer.

11.2.3 The seal, as well as the push rod area of the brake chamber (18) (see arrow **C**) must be clean and free of lubrication.

The seal must not show any signs of damage.

Note, if the brake chamber's seal protrudes less than **3 mm** the brake chamber must be replaced (see Fig.).

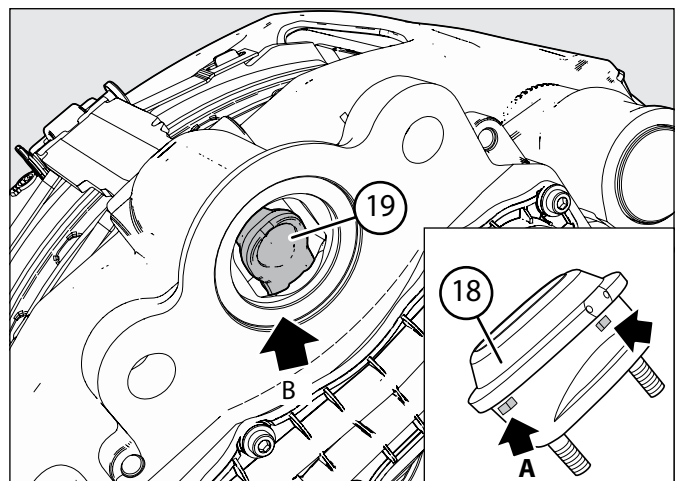

11.2.1 - 11.2.2 - Check seal and flange surface of caliper, grease spherical cup and flange surface

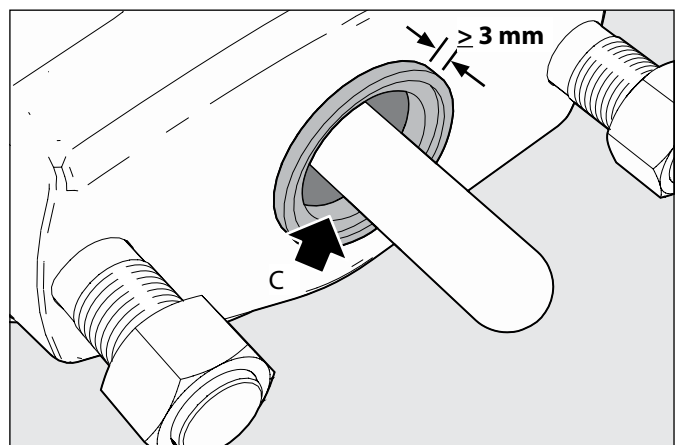

11.2.3 - Check seal, min. 3 mm

11 Brake Actuator Replacement

1....
2....
3....

11.2.4 Attach brake chamber using new nuts (see Fig.).
In order not to tilt the brake chamber during its attachment, the nuts must be gradually tightened symmetrically with a suitable tool.

11.2.5 Tighten the nuts according to the specifications of the actuator manufacturer.

Note: only use new self-locking nuts.

11.2.6 Connect air hose, making sure that the hose is not twisted and chafing is not possible.

11.2.7 Check air connection for leakage.

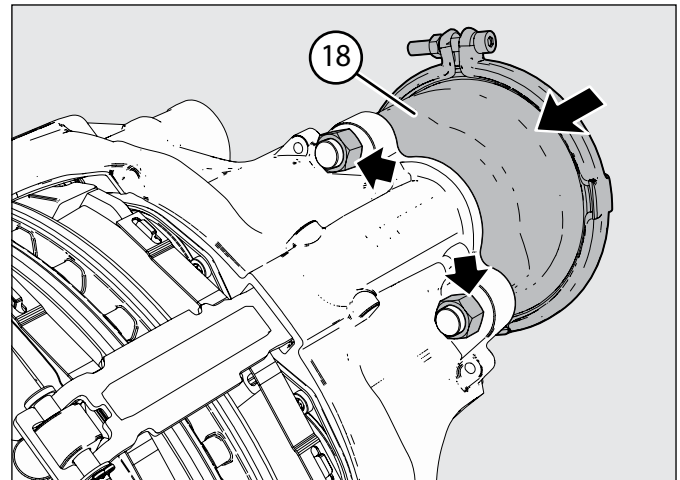

11.2.4 - Attach brake chamber

 Check function and effectiveness of the service brake system.

11.3 Removal of Knorr-Bremse Spring Brake

 Chock wheels before releasing spring brake to ensure the vehicle cannot roll away.

11.3.1 Release parking brake.

11.3.2 Screw-out release bolt (arrow **D**) to the release position (refer to the vehicle manufacturer's recommendations) (see Fig.).

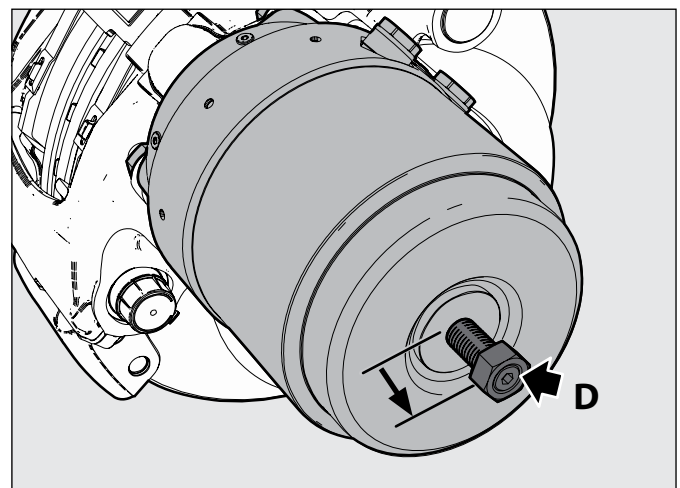

11.3.2 - Screw out release bolt

11.3.3 Apply parking brake.

11.3.4 Disconnect air connections from spring brake (18) – **take care, air connections must be free of air pressure.**

11.3.5 Unscrew spring brake mounting nuts (see arrows) and remove the spring brake (18) (see Fig.).

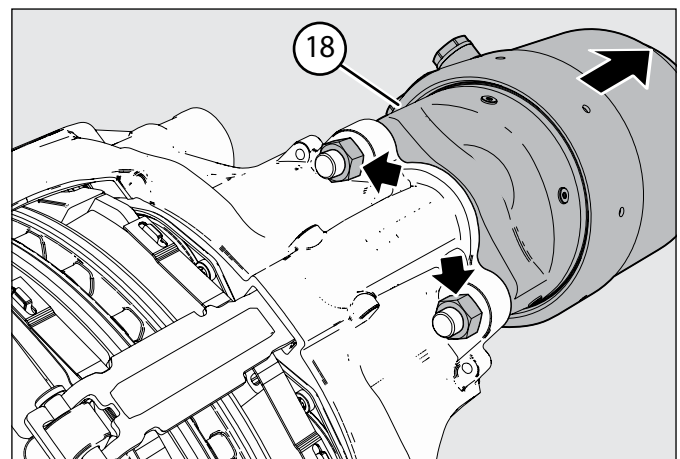

11.3.5 - Knorr-Bremse spring brake removal

 It is not allowed to reuse the nuts of the spring brake (18).

11 Brake Actuator Replacement

1....
2....
3....

11.4 Fitting of Knorr-Bremse Spring Brake

Note: New spring brakes (18) have drain plugs installed (see arrow **A**). Remove lowest plug (as viewed when spring brake is installed). All other drain holes should be plugged. Refer to the vehicle manufacturer's recommendations.

11.4.1 The sealing surface and the flange surface (see Fig. arrow **B**) must be:

- free from dust and corrosion
- free from damage
- flat

Take care that no dirt enters the brake caliper!

11.4.2 Before fitting the new spring brake, the spherical cup (19) in the lever and the sealing surface must be greased with white grease (Part No. II14525, K093430 or II32868).

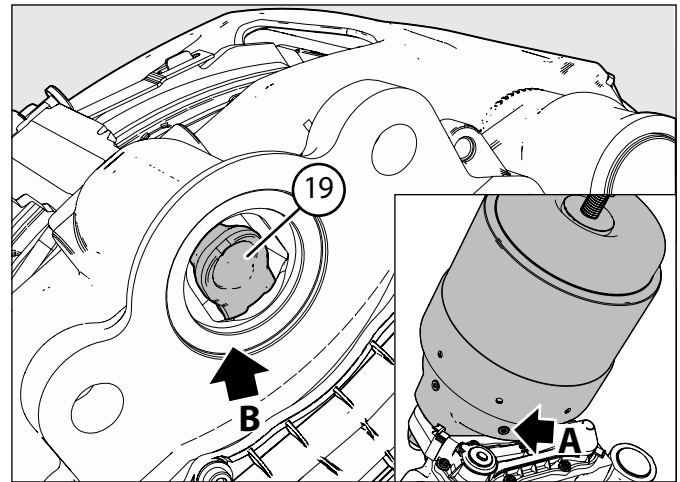

11.4.1 - 11.4.2 - Check seal and flange surface of caliper, grease spherical cup

⚠ Do not use grease containing molybdenum disulphide. Use only actuators which are recommended by the vehicle manufacturer.

11.4.3 The seal, as well as the push rod area of the spring brake (18) (see arrow **C**) must be clean and free of lubrication.

The seal must not show any signs of damage.

Note, if the spring brake's seal protrudes less than **3 mm** the spring brake must be replaced (see Fig.).

11.4.4 Attach the spring brake using new nuts (see Fig.).

Note: In order not to tilt the spring brake during its attachment, the nuts must be gradually tightened symmetrically with a suitable tool.

11.4.5 Tighten the nuts according to the specifications of the actuator manufacturer.

Note: Only use new nuts.

11.4.6 Connect air hoses, making sure that the hoses are not twisted and chafing is not possible.

11.4.7 Release parking brake.

11.4.8 Screw in spring brake release bolt as per instructions on the spring brake itself.

11.4.9 Check air connections for leakage.

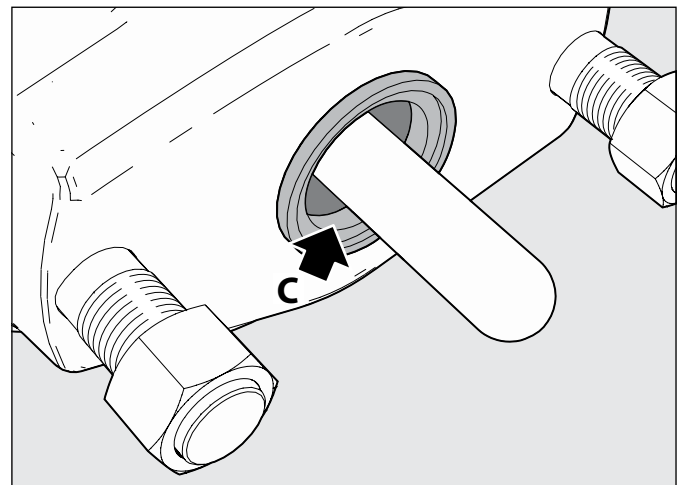

11.4.3 - Check seal, min. 3 mm

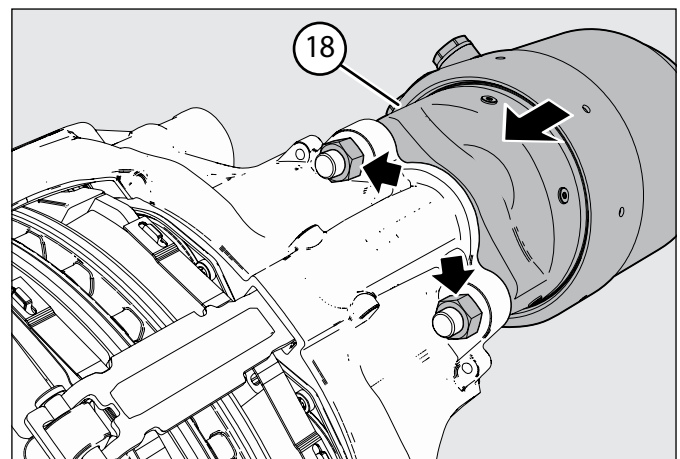

11.4.4 - Knorr-Bremse spring brake fitting

⚠ Check function and effectiveness of the service brake system and parking brake system.

Knorr-Bremse Systems for Commercial Vehicles

Moosacher Strasse 80 | 80809 Munich | Germany

Tel: +49 89 3547-0

mytruckservices.knorr-bremse.com



Disclaimer: The information contained in this document is intended for the exclusive use of trained persons within the commercial vehicle industry, and must not be passed on to any third party.

All recommendations regarding products and their servicing or usage are with reference to Knorr-Bremse products and should not be considered applicable to products from other manufacturers.

This information does not purport to be all-inclusive and no responsibility is assumed as a result of its use. We cannot accept any liability nor offer any guarantee regarding data accuracy, completeness or timeliness. The information does not represent any guarantee or ensured characteristics of the Products or Systems described.

No liability can be accepted based on the information, its use, recommendations or advice provided. In no event may we be held liable for any damage or loss except in the case of wilful intent or gross negligence on our part, or if any mandatory legal provisions apply.

The information contained herein is subject to alteration without notice and therefore may not be the latest release. Please check our website mytruckservices.knorr-bremse.com for the latest update or contact your local Knorr-Bremse representative. The figurative mark "K" and the trademarks KNORR and KNORR-BREMSE are registered in the name of Knorr-Bremse AG. Additional terms and conditions apply; please refer to our website truckservices.knorr-bremse.com for full Disclaimer.

Any legal disputes arising from the use of this information shall be subject to German law.

Note: If service work is carried out on a vehicle based on information provided herein, it is the responsibility of the workshop to ensure the vehicle is fully tested and in full functional order before the vehicle is returned into service. Knorr-Bremse accepts no liability for problems caused as a result of appropriate tests not being carried out.

This disclaimer is a translation of a German text, which should be referred to for all legal purposes.

Copyright © Knorr-Bremse AG - all rights reserved, including industrial property rights applications. Knorr-Bremse AG retains any power of disposal, such as for copying and transferring.