



FUWA K HITCH (Australia) Pty Ltd

ABN 54 078 731 209

Head Office

Melbourne

13-21 Bliss Court
Derrimut VIC 3026
Tel. 03 9369 0000
Fax. 03 9369 0100

Queensland

41 Moreton
Heathwood Qld 4110
Tel. 07 3372 2223
Fax. 07 3372 1022

Perth

5 Freight Road
Kenwick WA 6107
Tel. 08 9350 6470
Fax. 08 9350 6570

SALES SPEC SHEET

SELF STEER AXLE KSS1



The **assali STEFEN** self steer axle

is proven design, which has been successfully operated in the Australian market for many years.

The following model information is specific to the KSS1, but features like induction hardened bearing journals, premium bearings and seals and OE quality brake linings are standard to all FUWA K HITCH distributed axles.

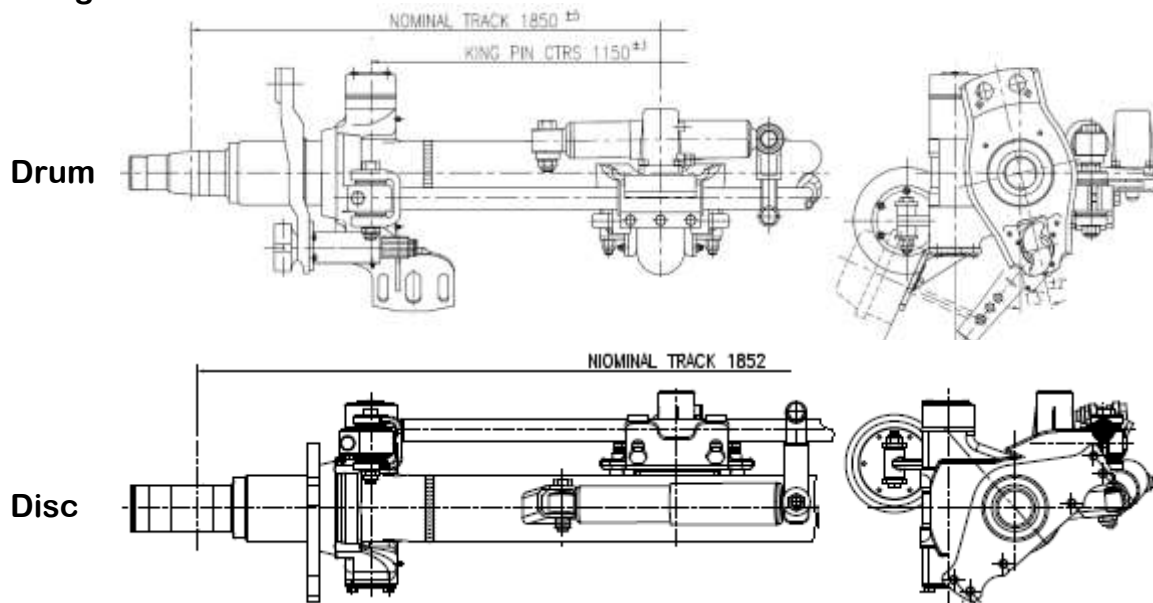

CAPACITY TON	BEARING TYPE	BRAKE TYPE	S-CAM SIZE	S-CAM TYPE	WHEEL END OPTIONS	SARN CTA
10.0t	TN	Ø420x180 (16.5"x7") GP-"Q" Brake	1-1/2" - 10 Spline	ENCLOSED	<ul style="list-style-type: none"> •8x275 (Disc ONLY) •10x285 •Iron ConMet Preset Plus 10x285(Drum ONLY) •10x335 •5 SPOKE (Drum ONLY) 	35665 CTA-035665
		Disc Pan19 only				30241 CTA-030241

CAPACITY TON	BEARING TYPE	BRAKE TYPE	S-CAM SIZE	S-CAM TYPE	WHEEL END OPTIONS	SARN CTA
10.0t	TP	Ø420x180 (16.5"x7") GP-"Q" Brake	1-1/2" - 10 Spline	ENCLOSED	<ul style="list-style-type: none"> •10x285 •Alum & Iron ConMet Preset Plus 10x285 •10x335 •5 SPOKE 	35665 CTA-035665
		Disc Pan 19 & 22 (Not currently available)				



FUWA K HITCH (Australia) Pty Ltd

ABN 54 078 731 209

Head Office

Melbourne

13-21 Bliss Court
Derrimut VIC 3026
Tel. 03 9369 0000
Fax. 03 9369 0100

Queensland

41 Moreton
Heathwood Qld 4110
Tel. 07 3372 2223
Fax. 07 3372 1022

Perth

5 Freight Road
Kenwick WA 6107
Tel. 08 9350 6470
Fax. 08 9350 6570

TRACK	STEER ANGLE	C-C BOOSTERS	WEIGHT	ABS	AXLE BEAM SIZE	LUBE
1850	12°	1030	500KG*	Pole ring fitted Sensor mounting fitted	Ø127x25	GREASE (Oil on request)

Note*: Specific configuration KSS12AG15LAN50S33ABS

KSS1 SERVICE INFORMATION

BULLETIN NUMBER	TOPIC	DESCRIPTION
KPW-002-0110	Warranty	Limitation of Liabilities
KPW-004-0110		LGL's
KPM-001-0110		Claim Form
MAN0032 assaliSTEFEN	Installation	Operating and Maintenance Manual Application specific engineering drawings are available upon request.
KPS-001-0513	Parts	Parts View
MAN0032 assaliSTEFEN	Maintenance	Operating and Maintenance Manual

Bulletins:

All Bulletins are on: www.khitch.com.au

...or call FKH at your nearest location.

